

# SLS

## Mini slide

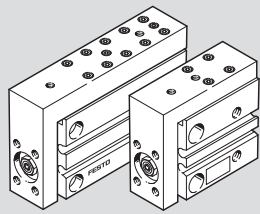

# FESTO

Festo SE & Co. KG  
Ruiter Straße 82  
73734 Esslingen  
Germany  
+49 711 347-0

www.festo.com

Operating instruction

8166211  
2022-11d  
[8166213]



8166211

Translation of the original instructions

© 2022 all rights reserved to Festo SE & Co. KG

## 1 Applicable Documents

All available documents for the product → [www.festo.com/sp](http://www.festo.com/sp).

## 2 Safety

### 2.1 Safety instructions

- Only use the product in its original condition without unauthorised modifications.
- Take into account the ambient conditions at the location of use.
- Observe the identifications on the product.
- Store the product in a cool, dry environment protected from UV and corrosion. Keep storage times short.
- Before working on the product, switch off the compressed air supply and lock it to prevent it from being switched on again.

### 2.2 Intended use

The mini slide moves workpieces with a high level of positioning accuracy in the tightest of spaces.

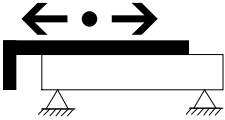

Fig.1

### 2.3 Training of qualified personnel

Work on the product may only be carried out by qualified personnel who can evaluate the work and detect dangers. The qualified personnel have skills and experience in dealing with pneumatic (open-loop) control technology.

## 3 Additional information

- Contact the regional Festo contact if you have technical problems → [www.festo.com](http://www.festo.com).
- Accessories and spare parts → [www.festo.com/catalogue](http://www.festo.com/catalogue).

## 4 Product design

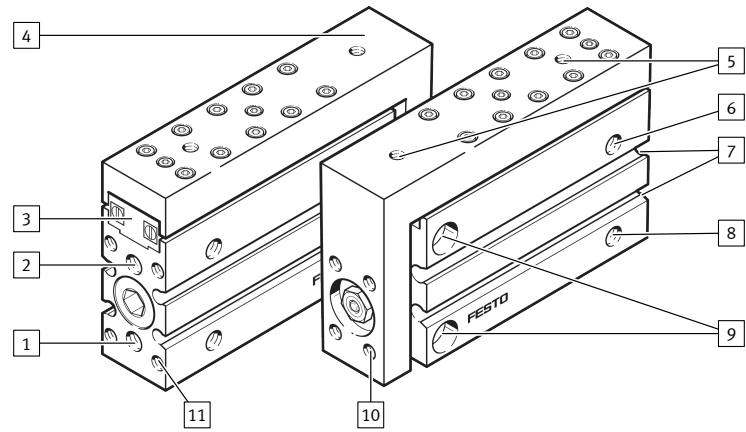

Fig. 2: Product design

- |   |  |    |   |
|---|--|----|---|
| 1 | Supply port, extending   | 7  | Slot for proximity switch (4x)  |
| 2 | Supply port, retracting  | 8  | Option for side connection: supply port, extending, remove plug screw |
| 3 | Rail of the roller bearing guide                                       | 9  | Holes for mounting the slide unit, on the side (2x)                   |
| 4 | Slide  | 10 | Thread for mounting the payload, front (4x)                           |
| 5 | Thread for mounting the payload, above (2x)                            | 11 | Thread for mounting the slide unit, rear (4x)                         |
| 6 | Option for side connection: supply port, retracting, remove plug screw |    |   |

## 5 Function

The product is a non-rotating, double-acting cylinder with roller bearing guide. The slide is moved back and forth by alternate pressurisation of the supply ports. The slide is braked at the end position by internal, elastic cushioning without end-position adjustment.

## 6 Assembly

### 6.1 Preparation

1. Mount the product without torsional stresses.
2. Mount the product on a mounting surface with a flatness of 0.05% of the stroke length, but max. 0.1 mm.
3. If necessary: select the mounting components or the accessories. To prevent collisions: mount the mounting components outside the positioning range.

### 6.2 Mounting the mini slide

- Tighten the screws evenly.

SLT	-6	-10	-16
Thread for mounting the payload, above [5]			
Screws	2x		
Thread	M3	M4	
Max. tightening torque [Nm]	2	5	
Holes for mounting the slide unit, on the side [9]			
Screws	2x		
Thread	M3	M4	
Max. tightening torque [Nm]	2	5	
Thread for mounting the payload, front [10]			
Screws	4x		
Thread	M3	M4	
Max. tightening torque [Nm]	2	5	
Thread for mounting the slide unit, rear [11]			
Screws	4x		
Thread	M3	M4	
Max. tightening torque [Nm]	2	5	

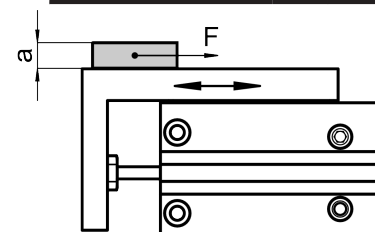

Fig. 3: Positioning the payload

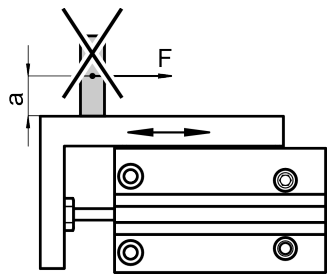

Fig. 4: Positioning the payload

- Position the payload on the slide in such a way that the break-down torque from the lever arm *a* and the static force *F* remains low.

### 6.3 Mounting the proximity switches

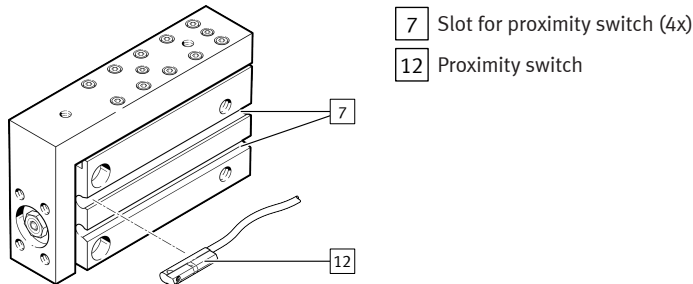

Fig. 5: Mounting proximity switches

- Slide the proximity switches [12] into the slots [7].
- Avoid external influence caused by magnetic or ferritic parts in the vicinity of the proximity switches. Check the required distance for the specific application.

SLS	-6	-10	-16
Distance to other magnetic or ferritic parts [mm]	10	15	20

- To prevent contamination: use slot covers on all unused slots  
→ [www.festo.com/catalogue](http://www.festo.com/catalogue).

### 6.4 Mounting one-way flow control valves

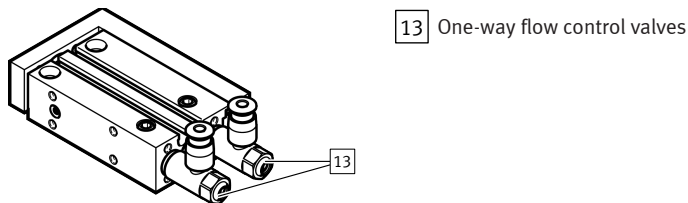

Fig. 6: Mounting one-way flow control valves

- Use one-way flow control valves [13] in the supply ports. They are screwed directly into the supply ports.

To secure the payload from dropping if the pressure fails:

- Use check valves.

## 7 Installation

- Connect tubing to supply ports:
  - Extending movement [1].
  - Retracting movement [2].

## 8 Commissioning

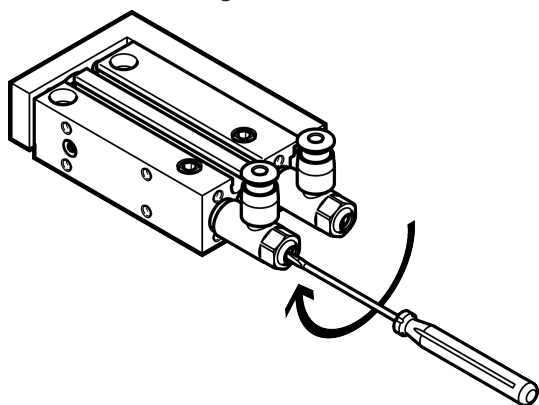

Fig. 7: Setting one-way flow control valves

- First of all, fully close the one-way flow control valves on both sides, then open them one complete revolution.
- Pressurise the drive on both sides simultaneously.
  - The slide moves slightly to a point of balance.
- Then exhaust the drive on one side.
  - The slide moves to an end position.

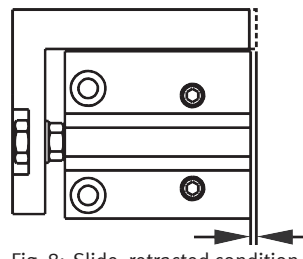

Fig. 8: Slide, retracted condition

- When retracted, the slide can protrude by a maximum of 0.75 mm.
- Start the test run.
- If needed: correct speed at the one-way flow control valves. The slide should reach the end positions without striking them harshly or recoiling.

## 9 Cleaning

Clean the product with a clean, soft cloth and non-abrasive cleaning agents.

For use with reduced particle emission:

- Remove abraded particles and soil from the product:
  - Prior to initial commissioning
  - Regularly during operation

## 10 Fault clearance

Malfunction	Cause	Remedy
The slide moves unevenly.	The one-way flow control valves are incorrectly installed.	- Control the exhaust air flow.
	The bearing surfaces are dirty.	- Clean the bearing surfaces.
The slide is in initial position despite pressurisation.	The payload is too high.	- Reduce the payload.
	The tubing is faulty.	- Check the tubing. - Check the blanking plugs.
The slide speed is too low.	The air volume is insufficient.	- Increase the connection cross-sections. - Check the flow control valve setting. - Connect a volume upstream.
	Reduced flow rate through angle fitting.	- Avoid angle fittings.
The slide strikes the end position harshly.	The speed is too high.	- Reduce the speed.
	The air cushion is not present.	- Pressurise both supply ports simultaneously, then exhaust one side.
	The payload is too high.	- Reduce the payload.

Tab. 1: Fault clearance

## 11 Technical data

### 11.1 Technical data, general

SLS	-6	-10	-16
Mode of operation	Double-acting		
Pneumatic connection	M5		
Mounting position	Any		
Ambient temperature [°C]	-20 ... +60		
Product weight			
SLS-...-5	[g] 97	130	225
SLS-...-10	[g] 104	139	226
SLS-...-15	[g] 113	149	256
SLS-...-20	[g] 120	164	257
SLS-...-25	[g] 131	182	291
SLS-...-30	[g] 141	191	301
Material			
Slide, housing	Anodised wrought aluminium alloy		
Piston rod	High-alloy stainless steel		
Guides	High-alloy steel, hardened and ground		
Seals	HNBR/PU		

Tab. 2: Technical data, general

### 11.2 Technical data, mechanical

SLS	-6	-10	-16
Cushioning	Internal elastic cushioning, without end-position adjustment		
Impact energy in the end positions [Nm]	0.008	0.05	0.15
Max. stroke frequency [Hz]	2		
Min. velocity [m/s]	0.05		
Max. velocity [m/s]	0.5	0.8	

SLS		-6	-10	-16
Theoretical payload				
At 0.6 MPa (6 bar; 87 psi) extending	[N]	17	47	121
At 0.6 MPa (6 bar; 87 psi) retracting	[N]	13	39	104

Tab. 3: Technical data, mechanical

### 11.3 Technical data, pneumatic

SLS		-6	-10	-16
Operating medium		Compressed air to ISO 8573-1:2010 [7:4:4]		
Information on the operating medium		Lubricated operation possible, in which case lubricated operation will always be required		
Operating pressure	[MPa]	0.15 ... 1	0.1 ... 1	
	[bar]	1.5 ... 10	1 ... 10	
	[psi]	21.75 ... 145	14.5 ... 145	

Tab. 4: Technical data, pneumatic