



Level



Pressure



Flow



Temperature



Liquid
Analysis



Registration



Systems
Components



Services



Solutions

Operating Instructions

Prosonic M FMU40/41/42/43/44

Ultrasonic Level Measurement

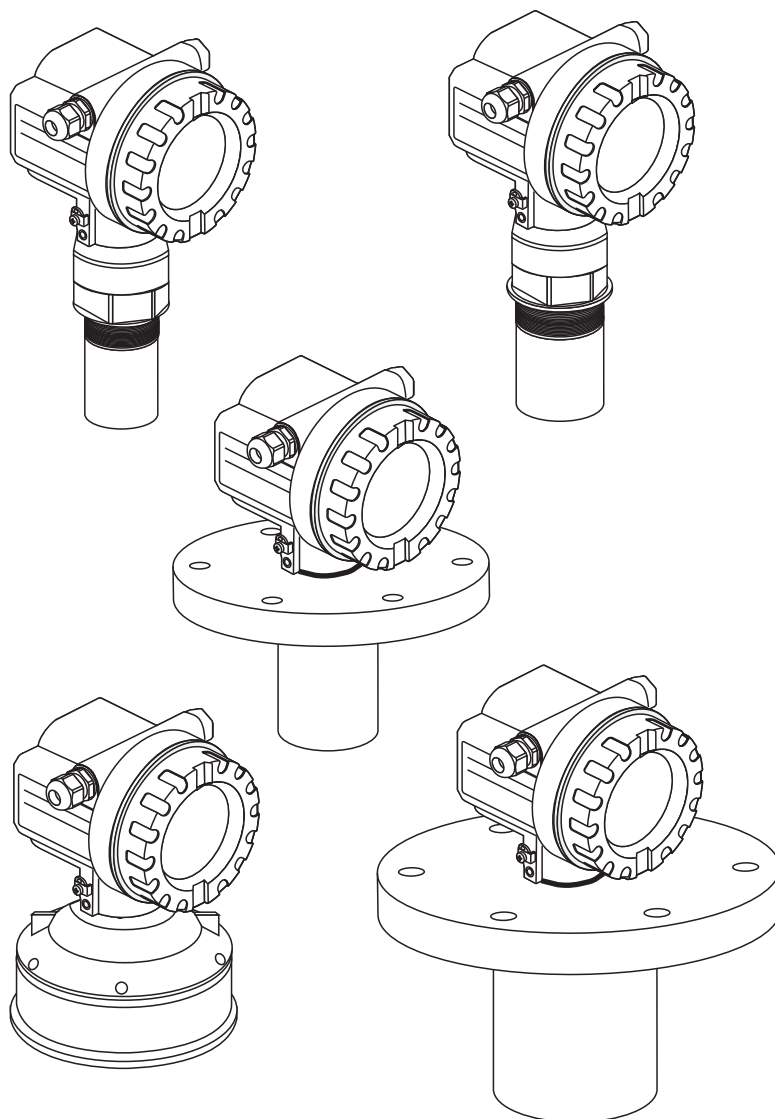

BA00239F/00/EN/13.12
71164392

Valid as of software version:
V 01.04

Table of contents

1	Safety instructions	4	6.4	Commissioning by the display and operating module VU331	44
1.1	Designated use	4	6.5	Commissioning with a FOUNDATION Fieldbus configuration tool	55
1.2	Installation, commissioning, operation	4	7	Troubleshooting	60
1.3	Operational safety and process safety	4	7.1	System error messages	60
1.4	Notes on safety conventions and symbols	5	7.2	Application errors	64
2	Identification	6	8	Maintenance and repairs	66
2.1	Nameplate	6	8.1	Exterior cleaning	66
2.2	Product structure FMU40	7	8.2	Repairs	66
2.3	Product structure FMU41	9	8.3	Repairs to Ex-approved devices	66
2.4	Product structure FMU42	10	8.4	Replacement	66
2.5	Product structure FMU43	12	8.5	Spare Parts	67
2.6	Product structure FMU44	13	8.6	Return	68
2.7	Scope of delivery	15	8.7	Disposal	68
2.8	Certificates and approvals	15	8.8	Software history	68
2.9	Registered trademarks	15	8.9	Contact addresses of Endress+Hauser	68
3	Installation	16	9	Accessories	69
3.1	Design; dimensions	16	9.1	Weather protection cover	69
3.2	Installation variants	19	9.2	Installation bracket for FMU40, FMU41	69
3.3	Installation conditions	21	9.3	Screw in flange	70
3.4	Measuring range	24	9.4	Cantilever	71
3.5	Installation hint for FMU40, FMU41	25	9.5	Mounting Frame	72
3.6	Turn housing	26	9.6	Wall Bracket	72
3.7	Post installation check	26	9.7	Mounting bracket for FMU 42/43/44	73
4	Wiring	27	9.8	Commubox FXA195 HART	73
4.1	Electrical connection	27	9.9	Commubox FXA291	73
4.2	Wiring with FOUNDATION Fieldbus plug	29	9.10	ToF Adapter FXA291	73
4.3	Cable specifications FOUNDATION Fieldbus	29	9.11	Remote display FHX40	74
4.4	Supply voltage	29	10	Technical Data	76
4.5	Recommended connection	30	10.1	Technical data at a glance	76
4.6	Post connection check	30	11	Appendix	82
5	Operation	31	11.1	Operating menu	82
5.1	Operation with the display and operating module VU331	31	11.2	Block model of the Prosonic M	84
5.2	Function codes	33	11.3	Resource block	85
5.3	Operating options	34	11.4	Sensor Block	86
5.4	On-site operation	34	11.5	Diagnostic Block	89
5.5	Operation using the on-site display VU331	35	11.6	Display Block	90
5.6	Remote operation	36	11.7	Analog input block	91
5.7	FieldCare operating program	36	11.8	List of start indices	95
5.8	Operation with a FOUNDATION Fieldbus configuration program	38	11.9	Measuring principle	96
5.9	Operation via Field Xpert SFX100	39	Index	98	
6	Commissioning	40			
6.1	Function check	40			
6.2	Unlocking the device	40			
6.3	Resetting the device	42			

1 Safety instructions

1.1 Designated use

The Prosonic M is a compact measuring device for continuous, non-contact level measurement. Depending on the sensor, the measuring range is up to 15 m (49 ft) in fluids and up to 7 m (23 ft) in bulk solids. By using the linearisation function, the Prosonic M can also be used for flow measurements in open channels and measuring weirs.

1.2 Installation, commissioning, operation

The Prosonic M is fail-safe and is constructed to the state-of-the-art. It meets the appropriate standards and EC directives. However, if you use it improperly or other than for its designated use, it may pose application-specific hazards, e.g. product overflow due to incorrect installation or configuration. Installation, electrical connection, start-up, operation and maintenance of the measuring device must therefore be carried out exclusively by trained specialists authorised by the system operator. Technical personnel must have read and understood these operating instructions and must adhere to them. You may only undertake modifications or repair work to the device when it is expressly permitted by the operating instructions.

1.3 Operational safety and process safety

Alternative monitoring measures must be taken to ensure operational safety and process safety during configuration, testing and maintenance work on the device.













Hazardous areas

Measuring systems for use in hazardous environments are accompanied by separate "Ex documentation", which is an integral part of this Operating Manual. Strict compliance with the installation instructions and ratings as stated in this Additional documentation is mandatory.

- Ensure that all personnel are suitably qualified.
- Observe the specifications in the certificate as well as national and local regulations.

1.4 Notes on safety conventions and symbols

In order to highlight safety-relevant or alternative operating procedures in the manual, the following conventions have been used, each indicated by a corresponding symbol in the margin.

Safety conventions	
	<p>Warning! A warning highlights actions or procedures which, if not performed correctly, will lead to personal injury, a safety hazard or destruction of the instrument</p>
	<p>Caution! Caution highlights actions or procedures which, if not performed correctly, may lead to personal injury or incorrect functioning of the instrument</p>
	<p>Note! A note highlights actions or procedures which, if not performed correctly, may indirectly affect operation or may lead to an instrument response which is not planned</p>
Explosion protection	
	<p>Device certified for use in explosion hazardous area If the device has this symbol embossed on its name plate it can be installed in an explosion hazardous area</p>
	<p>Explosion hazardous area Symbol used in drawings to indicate explosion hazardous areas. Devices located in and wiring entering areas with the designation "explosion hazardous areas" must conform with the stated type of protection.</p>
	<p>Safe area (non-explosion hazardous area) Symbol used in drawings to indicate, if necessary, non-explosion hazardous areas. Devices located in safe areas still require a certificate if their outputs run into explosion hazardous areas</p>
Electrical symbols	
	<p>Direct voltage A terminal to which or from which a direct current or voltage may be applied or supplied</p>
	<p>Alternating voltage A terminal to which or from which an alternating (sine-wave) current or voltage may be applied or supplied</p>
	<p>Grounded terminal A grounded terminal, which as far as the operator is concerned, is already grounded by means of an earth grounding system</p>
	<p>Protective grounding (earth) terminal A terminal which must be connected to earth ground prior to making any other connection to the equipment</p>
	<p>Equipotential connection (earth bonding) A connection made to the plant grounding system which may be of type e.g. neutral star or equipotential line according to national or company practice</p>
	<p>Temperature resistance of the connection cables States, that the connection cables must be resistant to a temperature of at least 85 °C (185 °F).</p>

2 Identification

2.1 Nameplate

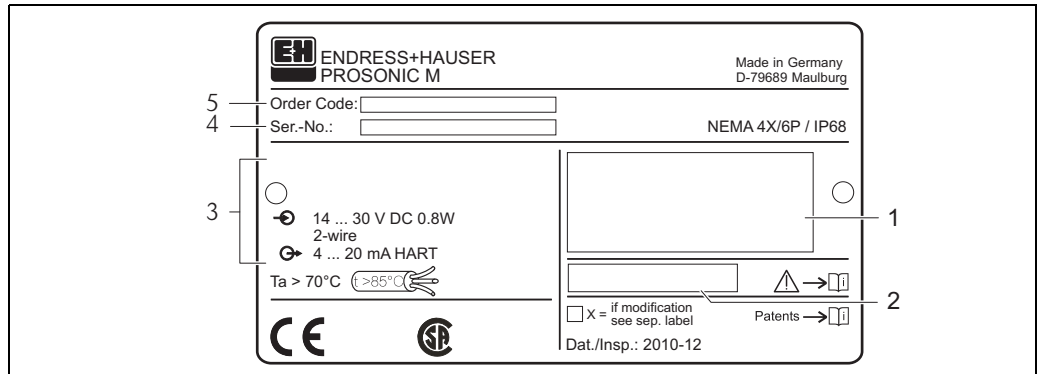

L00-FM114xxxx-18-00-00-yy-001

- 1 Designation according to Directive 94/9/EC and designation of the type of protection (only for certified device variants)
- 2 Reference to additional safety-relevant documentation (only for certified device variants)
- 3 Communication variant and supply voltage
- 4 Serial number
- 5 Order Code

2.2 Product structure FMU40

This overview does not mark options which are mutually exclusive.

010	Certificates	
	A	Variant for non-hazardous area
	E	NEPSI Ex nA II T6
	G	ATEX II 3G Ex nA IIC T6
	I	NEPSI Ex ia IIC T6
	J	NEPSI Ex d(ia) IIC T6
	K	TIIS EEx ia II C T6
	N	CSA General Purpose
	Q	NEPSI DIP
	S	FM IS Cl. I,II,III Div. 1 Gr. A-G / NI Cl. I Div. 2
	T	FM XP Cl. I,II,III Div. 1 Gr. A-G
	U	CSA IS Cl. I,II,III Div. 1 Gr. A-G / NI Cl. I Div. 2
	V	CSA XP Cl. I,II,III Div. 1 Gr. A-G
	1	ATEX II 1/2G EEx ia IIC T6
	2	ATEX II 1/2D, Alu blind cover
	4	ATEX II 1/2G EEx d (ia) IIC T6
	5	ATEX II 1/3D
	6	ATEX II 3D Ex t IIIC T* °C Dc
	Y	Special certificate
020	Process connection	
	R	G 1½" thread ISO 228
	N	NPT 1½" - 11,5 thread
	Y	Special version
030	Power supply/communication	
	B	2 wire, 4 to 20mA-loop/HART
	H	4 wire, 10,5 to 32VDC / 4-20mA HART
	G	4 wire, 90 to 253VAC / 4-20mA HART
	D	2 wire, PROFIBUS PA
	F	2 wire, FOUNDATION Fieldbus
	J	2-wire; 4-20mA HART, 5-point linearity protocol
	K	2-wire; PROFIBUS PA, 5-point linearity protocol
	L	2-wire; FOUNDATION Fieldbus, 5-point linearity protocol
	M	4-wire 90-250VAC; 4-20mA HART, 5-point linearity protocol
	N	4-wire 10,5-32VDC; 4-20mA HART, 5-point linearity protocol
	Y	Special version
040	Display / on-site operation	
	1	Without LC display
	2	With LC display VU331 incl. on-site operation
	3	Prepared for remote display FHX 40
	9	Special version
050	Housing	
	A	Aluminium F12 housing coated to IP68 NEMA6P
	C	Aluminium T12 housing coated to IP68 NEMA6P; with separate terminal compartment
	D	Aluminium T12 housing coated to IP68 NEMA6P+OVP; with separate terminal compartment; with overvoltage protection
	9	Special version
060	Screw union/entry	
	2	M20x1.5 screw union
	3	G 1/2" entry
	4	NPT 1/2" entry
	5	M12 PROFIBUS-PA plug-in connector
	6	7/8" FF plug
	9	Special version

995								Marking	
								1	Tagging (TAG)
								2	Bus address
FMU40 -									Product designation

2.3 Product structure FMU41

010	Certificates			
	A	Variant for non-hazardous area		
	E	NEPSI Ex nA II T6		
	G	ATEX II 3G Ex nA IIC T6		
	I	NEPSI Ex ia IIC T6		
	J	NEPSI Ex d(Ia) IIC T6		
	K	TIIS EEx ia IIC T6		
	N	CSA General Purpose		
	Q	NEPSI DIP		
	S	FM IS Cl. I,II,III Div. 1 Gr. A-G / NI Cl.I Div.2, zone 0,1,2		
	T	FM XP Cl. I,II,III Div. 1 Gr. A-G /zone 1,2		
	U	CSA IS Cl. I,II,III Div. 1 Gr. A-G / NI Cl. I Div. 2, zone 0,1,2		
	V	CSA XP Cl. I,II,III Div. 1 Gr. A-G / zone 1,2		
	1	ATEX II 1/2G EEx ia IIC T6		
	2	ATEX II 1/2D, Alu blind cover		
	4	ATEX II 1/2G EEx d (Ia) IIC T6		
	5	ATEX II 1/3D		
	6	ATEX II 3D Ex t IIIC T* °C Dc		
	Y	Special certificate		
020	Process connection			
	R	G 2" threadISO 228		
	N	NPT 2" - 11,5 thread		
	Y	Special version		
030	Power supply/communication			
	B	2 wire, 4 to 20mA-loop/HART		
	H	4 wire, 10,5 to 32VDC / 4-20mA HART		
	G	4 wire, 90 to 253VAC / 4-20mA HART		
	D	2 wire, PROFIBUS PA		
	F	2 wire, FOUNDATION Fieldbus		
	J	2-wire; 4-20mA HART, 5-point linearity protocol		
	K	2-wire; PROFIBUS PA, 5-point linearity protocol		
	L	2-wire; FOUNDATION Fieldbus, 5-point linearity protocol		
	M	4-wire 90-250VAC; 4-20mA HART,5-point linearity protocol		
	N	4-wire 10.5-32VDC;4-20mA HART,5-point linearity protocol		
	Y	Special version		
040	Display / on-site operation			
	1	Without LC display		
	2	With LC display VU331 incl. on-site operation		
	3	Prepared for remote display FHX 40		
	9	Special version		
050	Housing			
	A	Aluminium F12 housing coated to IP 68 NEMA 6P		
	C	Aluminium T12 housing coated to IP 68 NEMA 6P; with separate terminal compartment		
	D	Aluminium T12 housing coated to IP 68 NEMA 6P; with separate terminal compartment; with overvoltage protection		
	9	Special version		
060	Screw union/entry			
	2	M20x1.5 screw union		
	3	G 1/2" entry		
	4	NPT 1/2" entry		
	5	M12 PROFIBUS-PA plug-in connector		
	6	7/8" FF plug		
	9	Special version		
995	Marking			
	1	Tagging (TAG)		
	2	Bus address		
FMU41 -				Product designation

2.4 Product structure FMU42

010		Certificates	
	A	Variant for non-hazardous area	
	E	NEPSI Ex nA II T6	
	G	ATEX II 3G Ex nA IIC T6	
	I	NEPSI Ex ia IIC T6	
	J	NEPSI Ex d (Ia) IIC T6	
	K	TIIS EEx ia II C T6 (in preparation)	
	N	CSA General Purpose	
	Q	NEPSI DIP	
	S	FM IS Cl. I,II,III Div. 1 Gr. A-G / NI Cl. I Div. 2	
	T	FM XP Cl. I,II,III Div. 1 Gr. A-G	
	U	CSA IS Cl. I,II,III Div. 1 Gr. A-G / NI Cl. I Div. 2	
	V	CSA XP Cl. I,II,III Div. 1 Gr. A-G	
	1	ATEX II 1/2 G EEx ia IIC T6	
	2	ATEX II 1/2 D, Alu blind cover	
	4	ATEX II 1/2 G EEx d [ia] IIC T6	
	5	ATEX II 1/3D	
	6	ATEX II 3D Ex t IIIC T* °C Dc	
	Y	Special certificate	
020		Process connection	
	M	Mounting bracket FAU20	
	P	UNI flange 3"/DN80/80, PP, max. 2.5bar abs./ 36psia suitable for 3" 150lbs / DN80 PN16 / 10K 80	
	Q	UNI flange 3"/DN80/80, PVDF, max. 2.5bar abs./ 36psia suitable for 3" 150lbs / DN80 PN16 / 10K 80	
	S	UNI flange 3"/DN80/80, 316L, max. 2.5bar abs./ 36psia suitable for 3" 150lbs / DN80 PN16 / 10K 80	
	T	UNI flange 4"/DN100/100, PP, max. 2.5bar abs./ 36psia suitable for 4" 150lbs / DN100 PN16 / 10K100	
	U	UNI flange 4"/DN100/100, PVDF, max. 2.5bar abs./ 36psia suitable for 4" 150lbs / DN100 PN16 / 10K100	
	V	UNI flange 4"/DN100/100, 316L, max. 2.5bar abs./ 36psia suitable for 4" 150lbs / DN100 PN16 / 10K100	
	Y	Special version	
030		Power supply/communication	
	B	2 wire, 4 to 20mA-loop/HART	
	H	4 wire, 10,5 to 32VDC / 4-20mA HART	
	G	4 wire, 90 to 253VAC / 4-20mA HART	
	D	2 wire, PROFIBUS PA	
	F	2 wire, FOUNDATION Fieldbus	
	J	2-wire; 4-20mA HART, 5-point linearity protocol	
	K	2-wire; PROFIBUS PA, 5-point linearity protocol	
	L	2-wire; FOUNDATION Fieldbus, 5-point linearity protocol	
	M	4-wire 90-250VAC; 4-20mA HART,5-point linearity protocol	
	N	4-wire 10.5-32VDC;4-20mA HART,5-point linearity protocol	
	Y	Special version	
040		Display / on-site operation	
	1	Without LC display	
	2	With LC display VU331 incl. on-site operation	
	3	Prepared for remote display FHX 40	
	9	Special version	
050		Housing	
	A	Aluminium F12 housing coated to IP 68 NEMA 6P	
	C	Aluminium T12 housing coated to IP 68 NEMA 6P, with separate terminal compartment	
	D	Aluminium T 12 housing coated to IP 68 NEMA 6P, with separate terminal compartment; with overvoltage protection	
	Y	Special version	

060							Gland/Entry	
							2	M20x1.5 gland
							3	G 1/2“ entry
							4	NPT 1/2“ entry
							5	M12 PROFIBUS-PA plug
							6	7/8" FF plug
							9	Special version
070							Sealing Sensor/Flange	
							2	VITON flat sealing
							3	EPDM flat sealing
							9	special version
080							Additional options	
							A	Additional options not selected
995							Marking	
							1	Tagging (TAG)
							2	Bus address
FMU42 -								Product designation

2.5 Product structure FMU43

010	Certificates			
	A	Variant for non-hazardous area		
	2	ATEX II 1/2D, Alu blind cover		
	5	ATEX II 1/3D		
	6	ATEX II 3D Ex t IIIC T* °C Dc		
	M	FM DIP Cl.II Div.1 Gr.E-G, NI Cl.I Div.2, Zone 2		
	N	CSA General Purpose		
	P	CSA DIP Cl.II Div.1 Gr.E-G, NI Cl.I Div.2, zone 2		
	Q	NEPSI DIP		
	Y	Special version		
020	Process connection/material			
	P	Flange DN 100/ANSI 4"/JIS 16K100, PP (universal slip-on flange included)		
	S	Flange DN 100/ANSI 4"/JIS 16K100, SS 316TI (universal slip-on flange included)		
	K	Without slip-on flange/without mounting bracket (customer mounting equipment)		
	M	With mounting bracket FAU20		
	Y	Special version		
030	Power supply/communication			
	H	4 wire, 10,5 to 32VDC / 4-20mA HART		
	G	4 wire, 90 to 253VAC / 4-20mA HART		
	D	2 wire, PROFIBUS PA		
	F	2 wire, FOUNDATION Fieldbus		
	J	2-wire; 4-20mA HART, 5-point linearity protocol		
	K	2-wire; PROFIBUS PA, 5-point linearity protocol		
	L	2-wire; FOUNDATION Fieldbus, 5-point linearity protocol		
	M	4-wire 90-250VAC; 4-20mA HART,5-point linearity protocol		
	N	4-wire 10.5-32VDC;4-20mA HART,5-point linearity protocol		
	Y	Special version		
040	Display / on-site operation			
	1	Without LC display		
	2	4-line display VU331, Envelope curve display on site		
	3	Prepared for remote display FHX 40		
	9	Special version		
050	Housing			
	A	Aluminium F12 housing coated to IP 68 NEMA 6P		
	9	Special version		
060	Screw union/entry			
	2	M20x1.5 screw union		
	3	G 1/2" entry		
	4	NPT 1/2" entry		
	5	M12 PROFIBUS-PA plug-in connector		
	6	7/8" FF plug		
	9	Special version		
995	Marking			
	1	Tagging (TAG)		
	2	Bus address		
FMU43 -				Product designation

2.6 Product structure FMU44

010		Approval
	A	Non-hazardous area
	1	ATEX II 1/2G EEx ia IIC T6
	4	ATEX II 1/2G EEx d (ia) IIC T6
	G	ATEX II 3G Ex nA IIC T6
	2	ATEX II 1/2 D, Alu blind cover
	5	ATEX II 1/3 D
	6	ATEX II 3D Ex t IIIC T* °C Dc
	S	FM IS Cl.I,II,III Div.1 Gr.A-G, NI Cl.I Div.2, Zone 0,1,2 (in preparation)
	T	FM XP Cl.I,II,III Div.1 Gr.A-G, Zone 1,2 (in preparation)
	N	CSA General Purpose
	U	CSA IS Cl.I,II,III Div.1 Gr.A-G, NI Cl.I Div.2, zone 0,1,2
	V	CSA XP Cl.I,II,III Div.1 Gr.A-G
	K	TIIS EEx ia IIC T6 (in preparation)
	I	NEPSI Ex ia IIC T6 (in preparation)
	J	NEPSI Ex d(ia) IIC T6 (in preparation)
	E	NEPSI Ex nA II T6 (in preparation)
	Q	NEPSI DIP (in preparation)
	Y	Special version, to be specified
020		Process connection
	A	8" 150lbs FF, 316L, max 2.5bar abs./36psia
	E	UNI flange 6"/DN150/150, PP, max 2.5bar abs./ 36psia, suitable for 6" 150lbs / DN150 PN16 / 10K 150
	F	UNI flange 6"/DN150/150, PVDF, max 2.5bar abs./36psia, suitable for 6" 150lbs /DN150 PN16 / 10K 150
	G	UNI flange 6"/DN150/150, 316L, max 2.5bar abs. 36psia, suitable for 6" 150lbs / DN150 PN16 / 10K 150
	H	UNI flange DN200/200, PP, max 2.5bar abs./ 36 psia, suitable for DN200 PN16 / 10K 200
	J	UNI flange DN200/200, PVDF, max 2.5bar abs./ 36psia, suitable for DN200 PN16 / 10K 200
	K	UNI flange DN200/200, 316L, max 2.5bar abs./ 36psia, suitable for DN200 PN16 / 10K 200
	L	8" 150lbs FF, PP, max 2.5bar abs./ 36psia
	M	Mounting bracket FAU20
	N	8" 150lbs FF, PVDF, max 2.5bar abs./ 36psia
	T	UNI flange 4"/DN100/100, PP, max 2.5bar abs./ 36psia, suitable for 4" 150lbs / DN100 PN16 / 10K 100
	U	UNI flange 4"/DN100/100, PVDF, max. 2.5bar abs./ 36 psia, suitable for 4" 150lbs / DN100 PN16 / 10K 100
	V	UNI flange 4"/DN100/100, 316L, max 2.5bar abs./ 36psia, suitable for 4" 150lbs / DN100 PN16 / 10K 100
	Y	Special version, to be specified
030		Power supply; Output
	B	2-wire; 4-20mA HART
	D	2-wire; PROFIBUS PA
	F	2-wire; FOUNDATION Fieldbus
	G	4-wire 90-250VAC; 4-20mA HART
	H	4-wire 10.5-32VDC; 4-20mA HART
	J	2-wire; 4-20mA HART, 5-point linearity protocol
	K	2-wire; PROFIBUS PA, 5-point linearity protocol
	L	2-wire; FOUNDATION Fieldbus, 5-point linearity protocol
	M	4-wire 90-250VAC; 4-20mA HART,5-point linearity protocol
	N	4-wire 10.5-32VDC;4-20mA HART,5-point linearity protocol
	Y	Special version, to be specified
040		Operation
	1	w/o display, via communication
	2	4-line display VU331, Envelope curve display on site
	3	Prepared for FHX40, Remote display (accessory)
	9	Special version, to be specified

050										Housing
										A F12 Alu, coated IP68 NEMA6P
										C T12 Alu, coated IP68 NEMA6P, Separate conn. compartment
										D T12 Alu, coated IP68 NEMA6P + OVP, Sep. conn. compartment, OVP = overvoltage protection
										9 Special version, to be specified
060										Cable entry
										2 Gland M20 (EEx d > thread M20)
										3 Thread G1/2
										4 Thread NPT 1/2
										5 Plug M12
										6 Plug 7/8"
										9 Special version, to be specified
070										Process Sealing Sensor/ Flange
										2 Viton
										3 EPDM
										9 Special version, to be specified
080										Additional option
										A Basic version
										Y Special version, to be specified
995										Marking
										1 Tagging (TAG)
										2 Bus address
FMU44 -										complete product designation

2.7 Scope of delivery

2.7.1 Instrument and accessories

- Instrument according to the version ordered
- Accessories (→  69)
- Brief operating instructions KA01064F/00/EN for quick commissioning
- Brief operating instructions KA00183F/00/A2 (basic setup/troubleshooting), housed in the instrument)
- For certified instrument versions: Safety Instructions, Control- or Installation drawings
- For FMU40 *R**** and FMU41 *R****: counter nut (PC)
- For FMU40/41: sealing ring (EPDM)
- For gland M20x1.5:
 - 1 cable gland for 2-wire instruments
 - 2 cable glands for 4-wire instruments
 The cable glands are mounted on delivery.
- Endress+Hauser operating program on the enclosed CD-ROM
- CD-ROM with further documentation, e. g.
 - Technical Information
 - Operating Instructions
 - Description of Instrument Functions



Note!

Additional safety instructions (XA, ZE, ZD) are supplied with certified device versions. Refer to the nameplate for the names of the safety instructions that apply to your device version.

2.8 Certificates and approvals

CE mark, declaration of conformity

The device is designed to meet state-of-the-art safety requirements, has been tested and left the factory in a condition in which it is safe to operate. The device complies with the applicable standards and regulations as listed in the EC declaration of conformity and thus complies with the statutory requirements of the EC directives. Endress+Hauser confirms the successful testing of the device by affixing to it the CE mark.

2.9 Registered trademarks

FOUNDATION™ Fieldbus

Registered trademark of Fieldbus FOUNDATION Austin, Texas, USA

FieldCare®

Trademark of Endress+Hauser Process Solutions AG.

ToF®

Registered trademark of the company Endress+Hauser GmbH+Co. KG, Maulburg, Germany

PulseMaster®

Registered trademark of the company Endress+Hauser GmbH+Co. KG, Maulburg, Germany

3 Installation

3.1 Design; dimensions

3.1.1 FMU40, FMU41

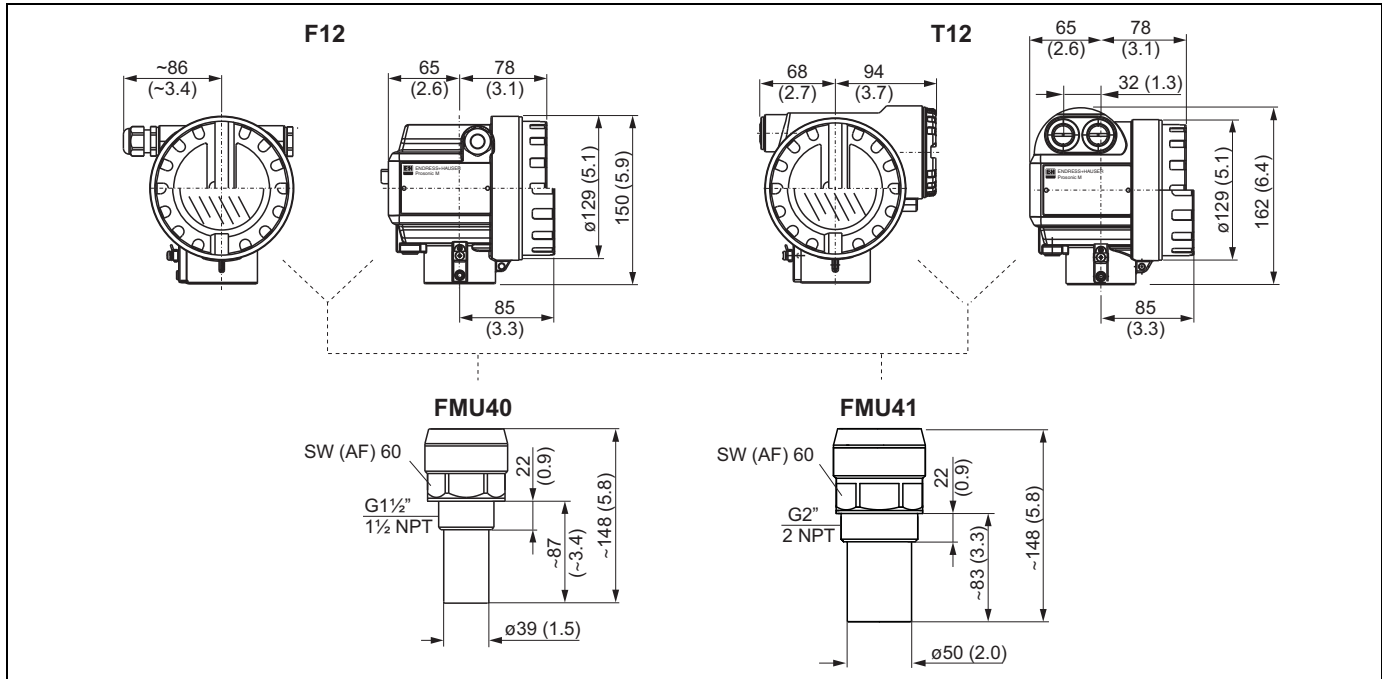

Dimensions in mm (in)

L00-FMU4xxxx-06-00-00-yy-006

3.1.2 FMU42, FMU44 with slip-on flange

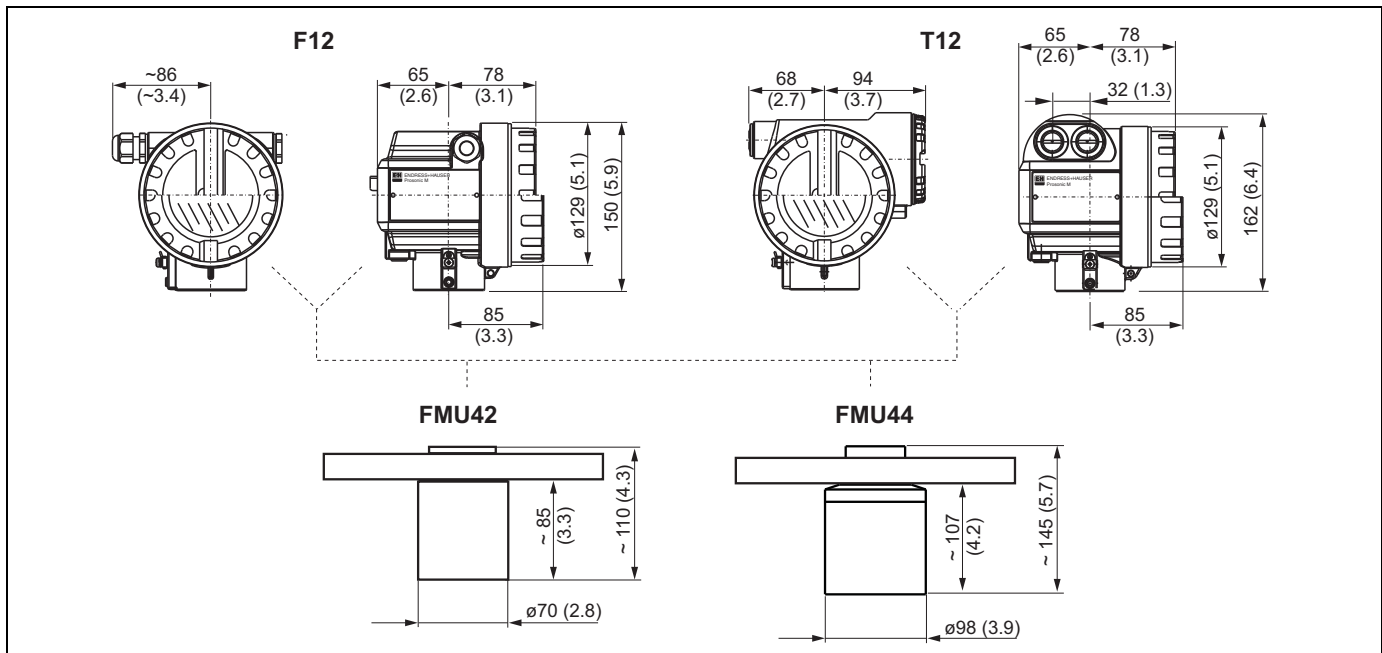

Dimensions in mm (in)

L00-FMU4xxxx-06-00-00-yy-007

3.1.3 FMU42, FMU44 with mounting bracket

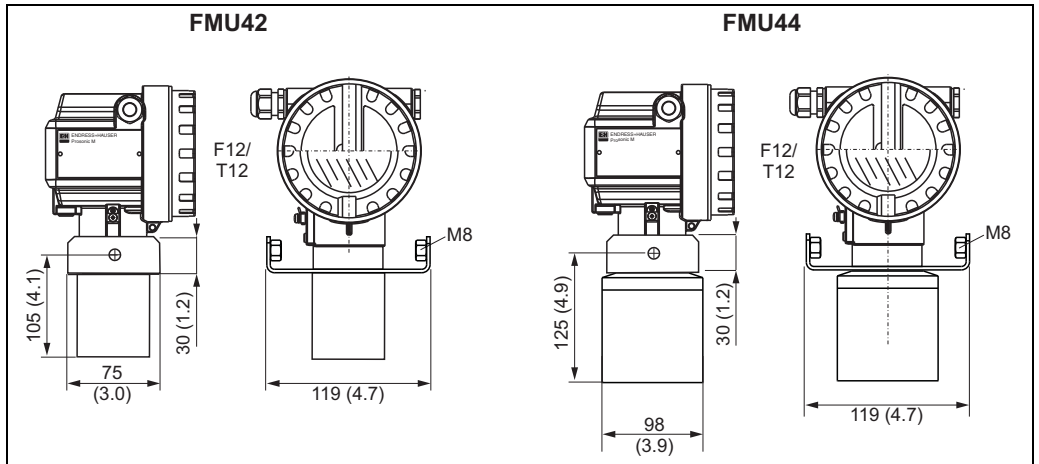

L00-FMU4xxxx-06-00-00-yy-006

Dimensions in mm (in)

3.1.4 FMU43

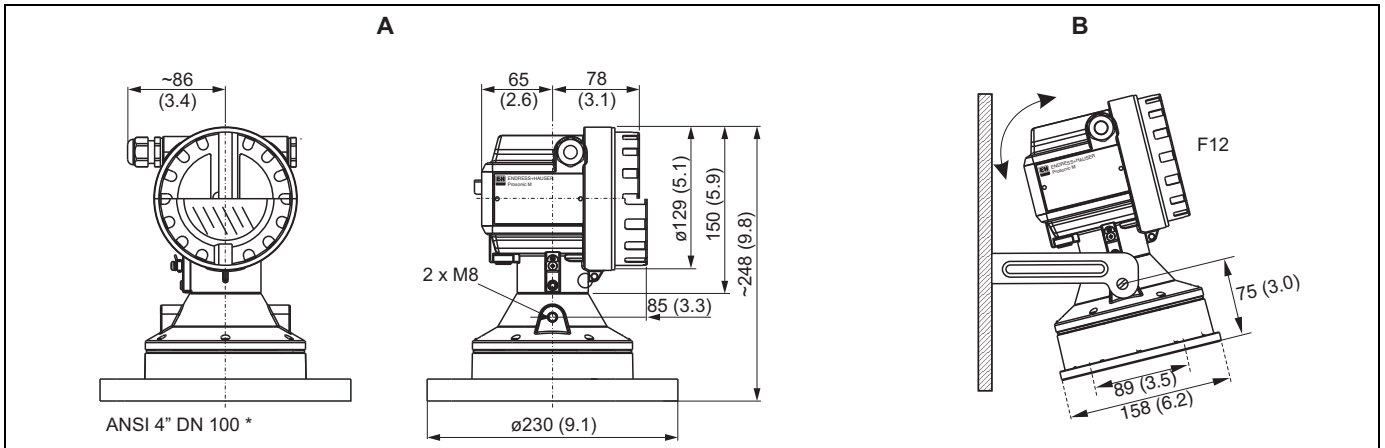

L00-FMU4xxxx-06-00-00-yy-006

Dimensions in mm (in)

A With slip-on flange

B With mounting bracket

3.1.5 Mounting bracket for FMU42, FMU43 and FMU44

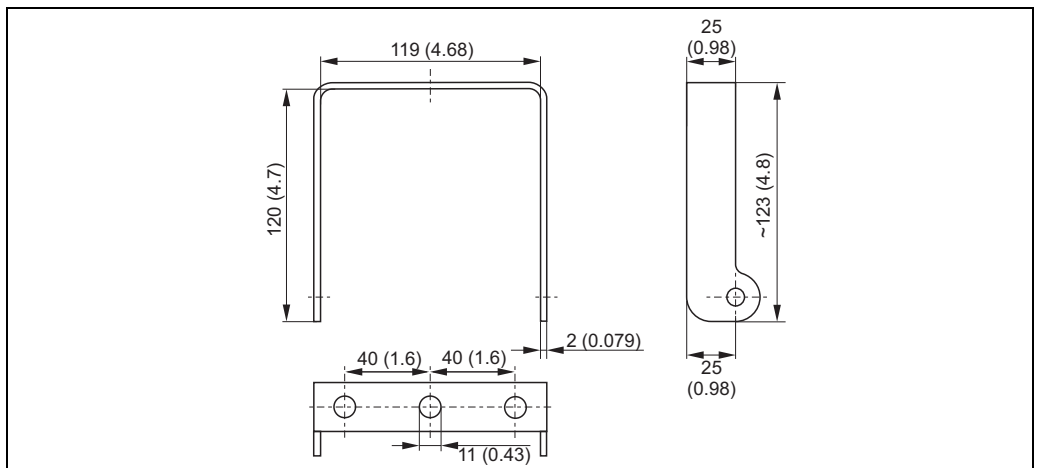

L00-FMU4xxxx-06-00-00-yy-010

Dimensions in mm (in)

3.1.6 Flanges for FMU42 and FMU44

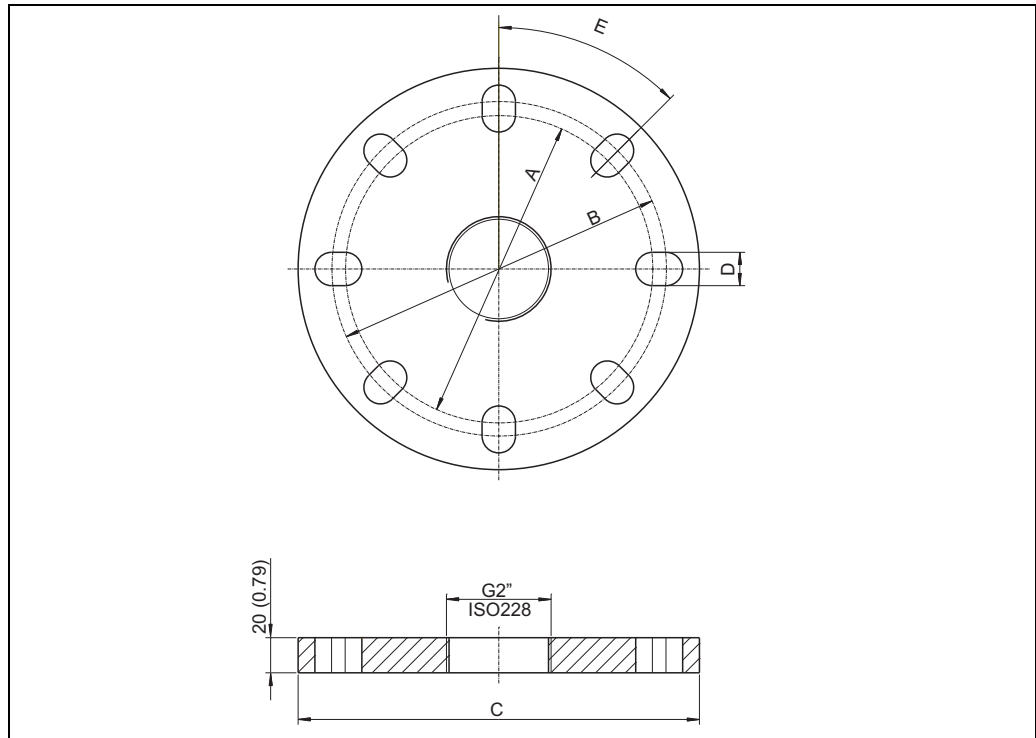

L00-FMU4xxxx-06-00-00-yy-011

Dimensions in mm (in)

suitable for	A	B	C	D	E	number of boreholes
3" 150 lbs / DN80 PN16 / 10 K 80	150 mm (5,91")	160 mm (6,30")	200 mm (7,87")	19 mm (0,75")	45°	8
4" 150 lbs / DN100 PN16 / 10 K 100	175 mm (6,90")	190,5 mm (7,50")	228,6 mm (9,00")	19 mm (0,75")	45°	8
6" 150 lbs / DN150 PN16 / 10 K 150	240 mm (9,45")	241,3 mm (9,50")	285 mm (11,22")	23 mm (0,91")	45°	8
8" 150 lbs	298,5 mm (11,75")	298,5 mm (11,75")	342,9 mm (13,50")	22,5 mm (0,89")	45°	8
DN200 PN16 / 10 K 200	290 mm (11,42")	295 mm (11,61")	340 mm (13,39")	23 mm (0,91")	30°	12

3.2 Installation variants

3.2.1 Installation variants FMU40, FMU41

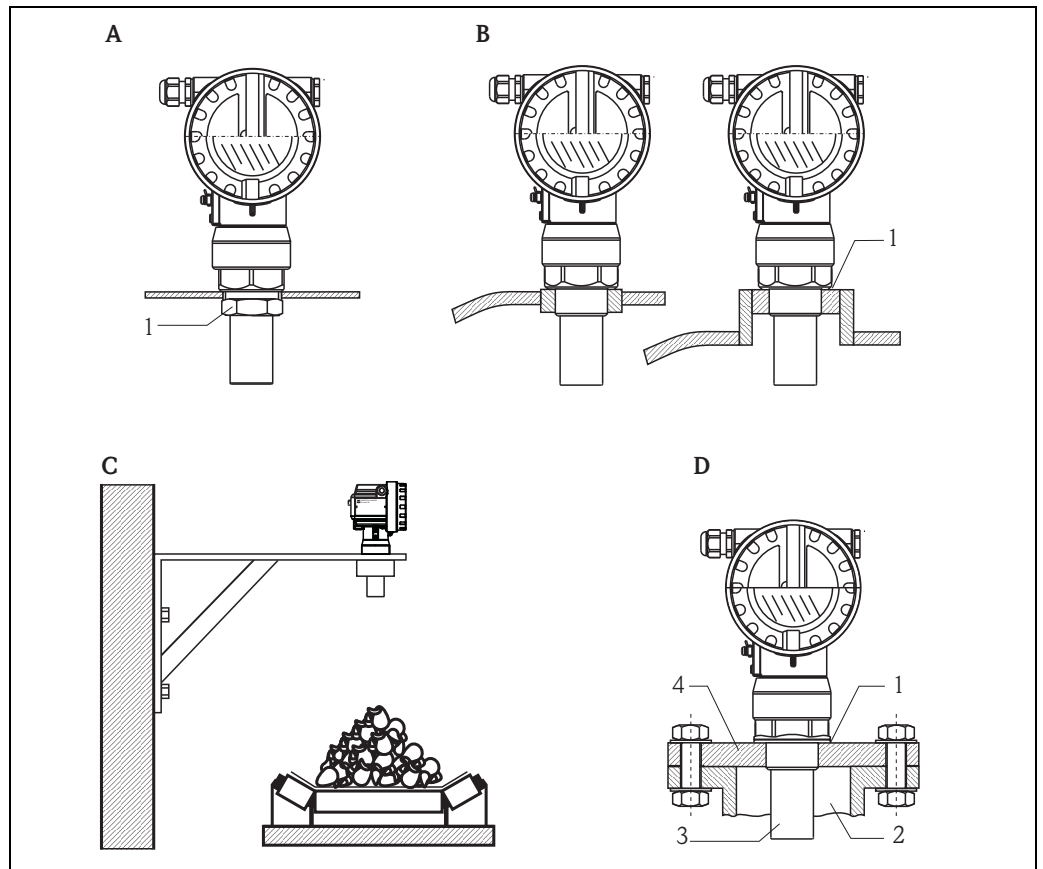

L00-FMU14xxxx-17-00-00-yy-002

- A** Installation with counter nut
 1 Counter nut (PC) supplied for G1½ and G2 instruments
- B** Installation with sleeve
 1 Sealing ring (EPDM) supplied
- C** Installation with installation bracket
- D** Installation with screw in flange
 1 Sealing ring (EPDM) supplied
 2 Nozzle
 3 Sensor
 4 Screw in flange

For installation bracket or adapter flange → 69, "Accessories".

3.2.2 Installation variants FMU42, FMU44

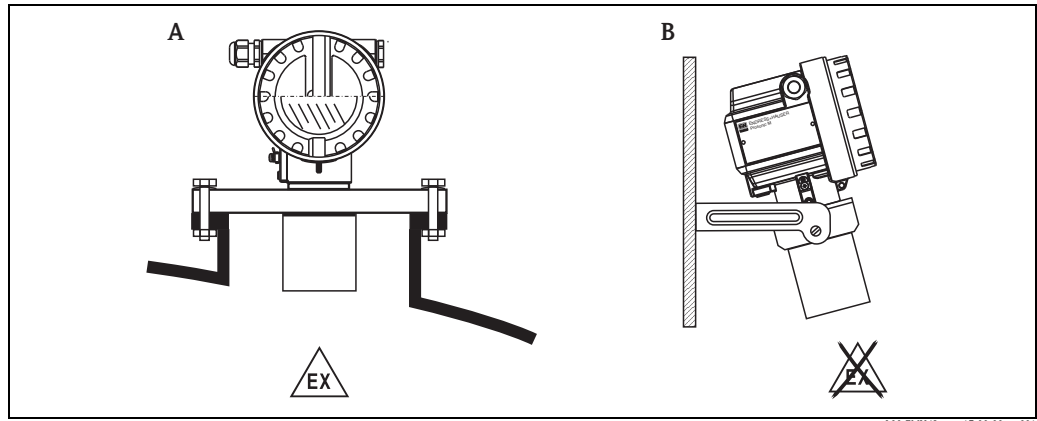

- A** Installation with universal flange (Ex-hazardous, e.g. Zone 20)
B Installation with mounting bracket, (Non-Ex-hazardous, Zone 20)

L00-FMU42xxxx-17-00-00-yy-001

3.2.3 Installation variants FMU43

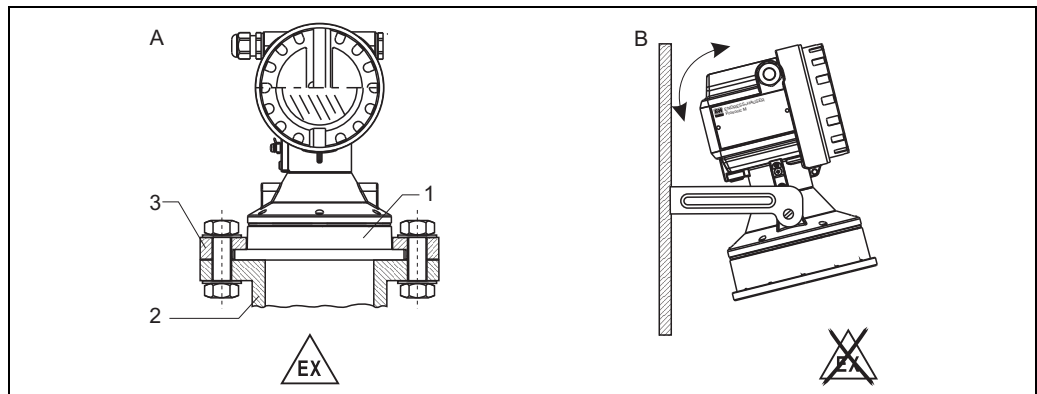

- A** Installation with universal slip-on flange (option)
 1 Sensor
 2 Nozzle
 3 Slip-on flange
B Installation with mounting bracket

L00-FMU43xxxx-17-00-00-yy-001

3.3 Installation conditions

3.3.1 Installation conditions for level measurements

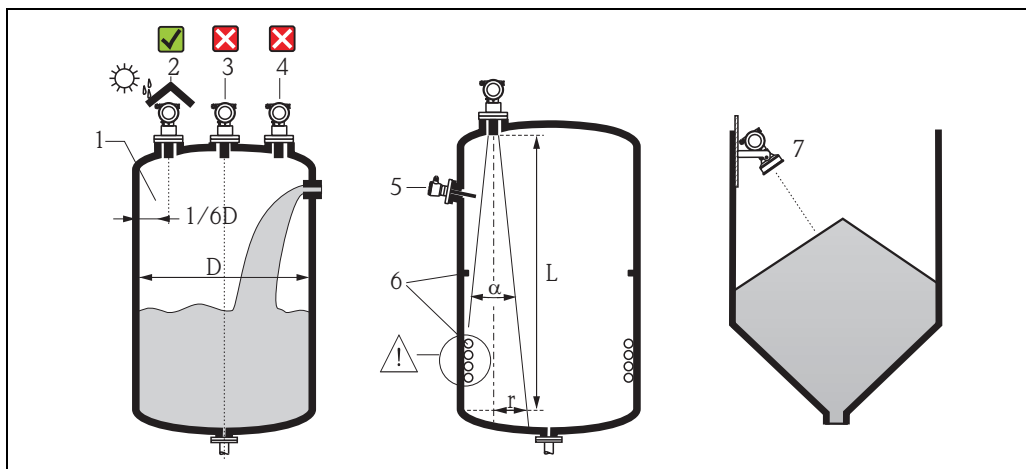

L00-FMU4xxxx-17-00-00-yy-005

- Do not install the sensor in the middle of the tank (3). We recommend leaving a distance between the sensor and the tank wall (1) measuring 1/6 of the tank diameter.
- Use a protective cover, in order to protect the device from direct sun or rain (2).
- Avoid measurements through the filling curtain (4).
- Make sure that equipment (5) such as limit switches, temperature sensors, etc. are not located within the emitting angle α . In particular, symmetrical equipment (6) such as heating coils, baffles etc. can influence measurement.
- Align the sensor so that it is vertical to the product surface (7).
- Never install two ultrasonic measuring devices in a tank, as the two signals may affect each other.
- To estimate the detection range, use the 3 dB emitting angle α .

Sensor	α	L_{max}	r_{max}
FMU40	11°	5 m (16 ft)	0.48 m (1.6 ft)
FMU41	11°	8 m (26 ft)	0.77 m (2.5 ft)
FMU42	9°	10 m (33 ft)	0.79 m (2.6 ft)
FMU43	6°	15 m (49 ft)	0.79 m (2.6 ft)
FMU44	11°	20 m (66 ft)	1.93 m (6.3 ft)

3.3.2 Installation in narrow shafts

In narrow shafts with strong interference echoes, we recommend using an ultrasound guide pipe (e.g. PE or PVC wastewater pipe) with a minimum diameter of 100 mm (3.94 in). Make sure that the pipe is not soiled by accumulated dirt. If necessary, clean the pipe at regular intervals.

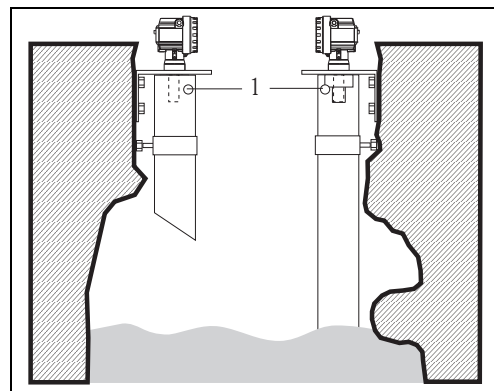

L00-FMU4xxxx-17-00-00-yy-010

1 Venting hole

3.3.3 Installation conditions for flow measurements

- Install the Prosonic M at the inflow side, as close above the maximum water level H_{\max} as possible (take into account the blocking distance BD).
- Position the Prosonic M in the middle of the channel or weir.
- Align the sensor membrane parallel to the water surface.
- Keep to the installation distance of the channel or weir.
- You can enter the "Flow to Level" linearisation curve ("Q/h curve") using the operating program or manually via the on-site display.

Example: Khafagi-Venturi flume

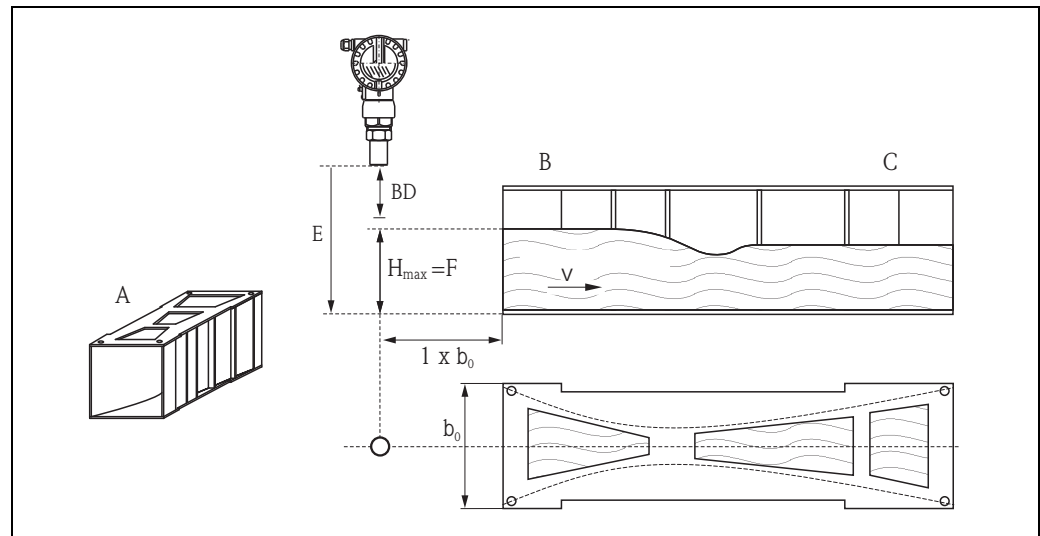

- A Khafagi-Venturi flume*
B Inflow
C Outflow
BD Blocking distance
E Empty calibration
F Full calibration
V Direction of flow

Example: Triangular weir

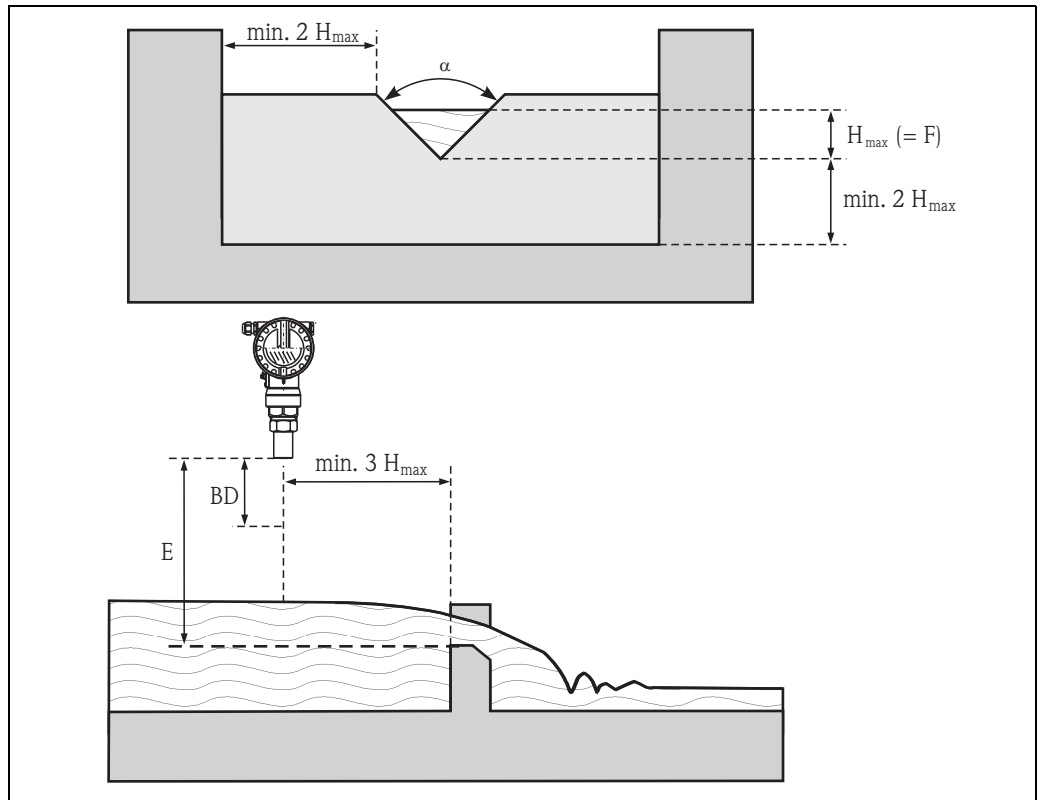

L00-FMU4xxxx-17-00-00-xx-012

- BD* Blocking distance
- E* Empty calibration
- F* Full calibration

3.4 Measuring range

3.4.1 Blocking distance, Nozzle mounting

Install the Prosonic M at a height so that the blocking distance BD is not undershot, even at maximum fill level. Use a pipe nozzle if you cannot maintain the blocking distance in any other way. The interior of the nozzle must be smooth and may not contain any edges or welded joints. In particular, there should be no burr on the inside of the tank side nozzle end. Note the specified limits for nozzle diameter and length. To minimise disturbing factors, we recommend an angled socket edge (ideally 45°).

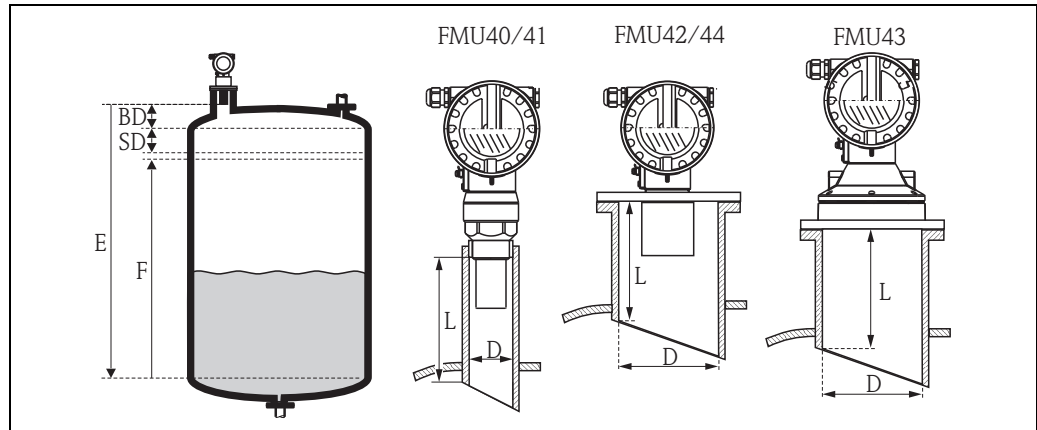

BD Blocking distance
SD Safety distance
E Empty calibration

F Full calibration (span)
D Nozzle diameter
L Nozzle length

Nozzle diameter	Maximum nozzle length [mm (in)]				
	FMU40	FMU41	FMU42	FMU43	FMU44
DN50/2"	80 (3.15)				
DN80/3"	240 (9.45)	240 (9.45)	250 (9.84)		
DN100/4"	300 (11.8)	300 (11.8)	300 (11.8)	300 (11.8)	
DN150/6"	400 (15.7)	400 (15.7)	400 (15.7)	300 (11.8)	400 (15.7)
DN200/8"	400 (15.7)	400 (15.7)	400 (15.7)	300 (11.8)	400 (15.7)
DN250/10"	400 (15.7)	400 (15.7)	400 (15.7)	300 (11.8)	400 (15.7)
DN300/12"	400 (15.7)	400 (15.7)	400 (15.7)	300 (11.8)	400 (15.7)
Sensor characteristics					
Emitting angle α	11°	11°	9°	6°	11°
Blocking distance [m (ft)]	0.25 (0.8)	0.35 (1.1)	0.4 (1.3)	0.6 (2.0)	0.5 (1.6)
Max. range [m (ft)] in liquids	5 (16.0)	8 (26.0)	10 (33.0)	15 (49.0)	20 (66.0)
Max. range [m (ft)] in solids	2 (6.6)	3.5 (11.0)	5 (16.0)	7 (23.0)	10 (33.0)



Caution!
If the blocking distance is undershot, it may cause device malfunction.

3.4.2 Safety distance

If the level rises to the safety distance SD, the device switches to warning or alarm status. The size of SD can be set freely in the "Safety distance" (015) function. The "in safety distance" (016) function defines how the device reacts if the level enters the safety distance.

There are three options:

- **Warning:** The device outputs an error message but continues measurement.
- **Alarm:** The device outputs an error message. The output signal assumes the value defined in the "Output on alarm" (011) function (MAX, MIN, user-specific value or holds the last value). As soon as the level drops below the safety distance, the device recommences measurement.
- **Self holding:** The device reacts in the same way as for an alarm. However, the alarm condition continues after the level drops below the safety distance. The device only recommences measurement when you cancel the alarm using the "Ackn. alarm" (017) function.

3.4.3 Range

The sensor range is dependent on the measuring conditions. Refer to Technical Information TI00365F/00/EN for an estimation. The maximum range is shown in the above diagram (valid for good conditions).

Sensor	Maximum range
FMU40	5 m (16 ft)
FMU41	8 m (26 ft)
FMU42	10 m (33 ft)
FMU43	15 m (49 ft)
FMU44	20 m (66 ft)

3.5 Installation hint for FMU40, FMU41

 **Caution!**
 Use only the screw-in piece to screw in the Prosonic M.
 Screw the Prosonic M at the screw-in piece using an 60 AF spanner.
 Maximum torque: 20 Nm (14.75 lbf ft).

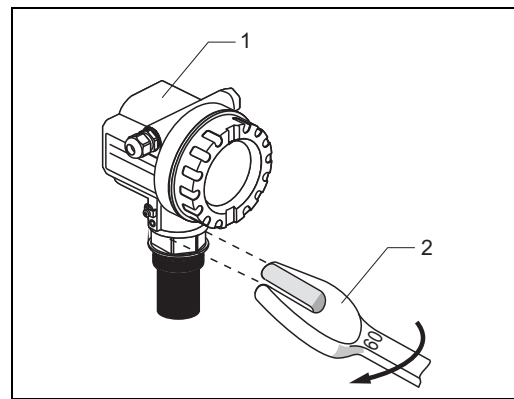

1 Housing F12 or T12
 2 60 AF

3.6 Turn housing

After mounting, the housing can be turned 350° in order to simplify access to the display and the terminal compartment. Proceed as follows to turn the housing to the required position:

- Undo the fixing screws (allen key 4 mm (0.16 in))
- Turn the housing in the required direction
- Tighten up the fixing screws. Maximum torque 0.5 Nm (0.36 lbf ft).
- Loctite can be used for securing the screw.

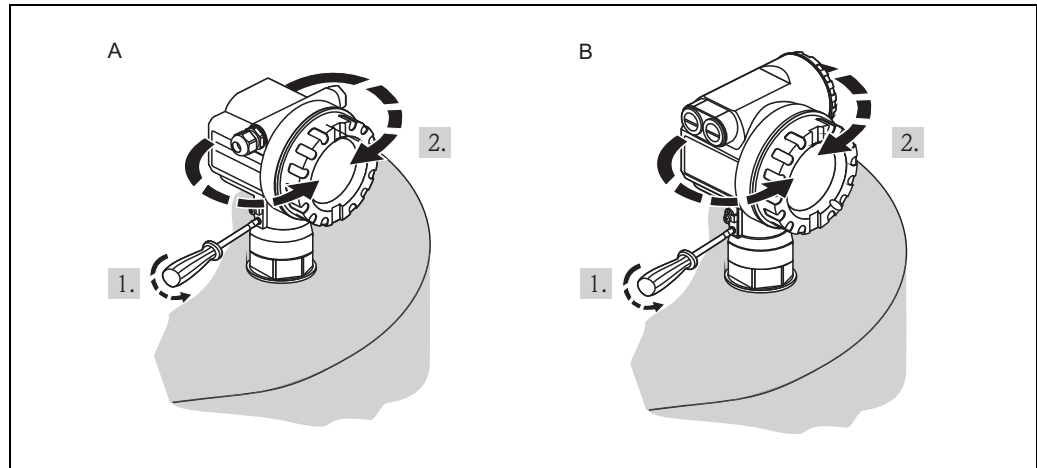

A Housing F12

B Housing T12

L00-FMU4xxxx-17-00-00-yy-013

3.7 Post installation check

After installing the device, carry out the following checks:

- Is the device damaged (visual inspection)?
- Does the device correspond to the measuring point specifications for process temperature, process pressure, ambient temperature, measuring range etc.
- If available: Are the measuring point number and labelling correct (visual inspection)?
- Is the measuring device sufficiently protected against precipitation and direct sunlight?
- Are the cable glands tightened correctly?
- After aligning the housing, check the process seal at the nozzle or flange.

4 Wiring

4.1 Electrical connection



Caution!

Before connection please note the following:

- The power supply must be identical to the data on the nameplate.
- Switch off power supply before connecting up the instrument.
- Connect equipotential bonding to transmitter ground terminal before connecting up the instrument (→ 30, "Recommended connection")



Warning!

When you use the measuring system in hazardous areas, make sure to comply with national standards and the specifications in the safety instructions (XA's). Make sure you use the specified cable gland.

4.1.1 Wiring in the housing F12

1. Unscrew housing cover (1).
2. Remove display (2) if fitted.
3. Remove cover plate (3) from terminal compartment.
4. Pull out terminal module (4) slightly using pulling loop.
5. Insert cable (5) through gland (6).



Caution!

If possible, insert the cable from above and let a draining loop in order to avoid intrusion of humidity.

6. Connect cable screen to the grounding terminal (7) within the terminal compartment.
7. Make connection according to terminal assignment (see below).
8. Re-insert terminal module (4).
9. Tighten cable gland (6).
10. Tighten screws on cover plate (3).
11. Insert display (2) if fitted.
12. Screw on housing cover (1).
13. Switch on power supply.

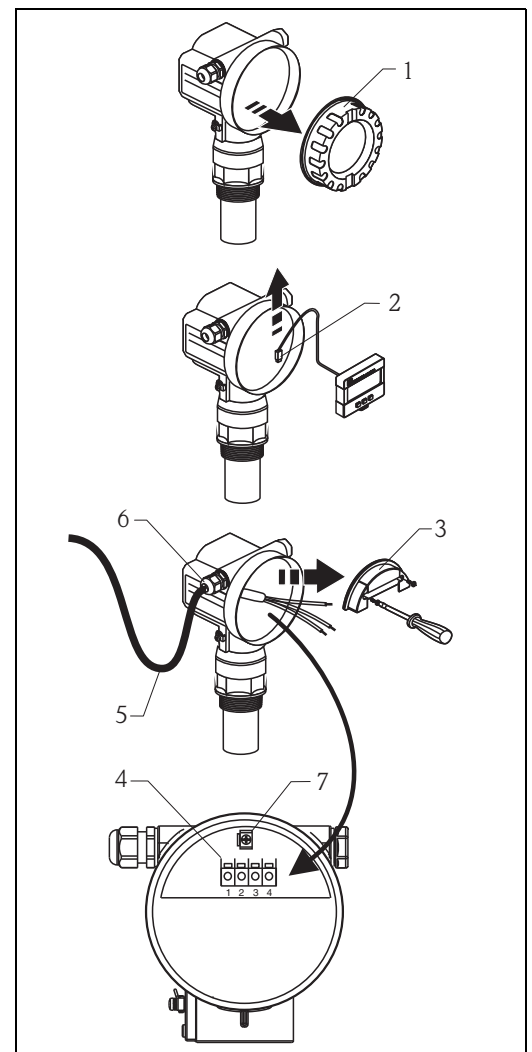

L00-FMU14xxxx-04-00-00-yy-008

4.1.2 Wiring in the housing T12

1. Unscrew the cover (1) of the separate connection room.
2. Insert cable (2) through gland (3).
3.  **Caution!**
If possible, insert the cable from above and let a draining loop in order to avoid intrusion of humidity.
3. Connect cable screen to the grounding terminal (4) within the connection room.
4. Make connection according to the terminal assignment (see below).
5. Tighten cable gland (3).
6. Screw on housing cover (1).
7. Switch on power supply.

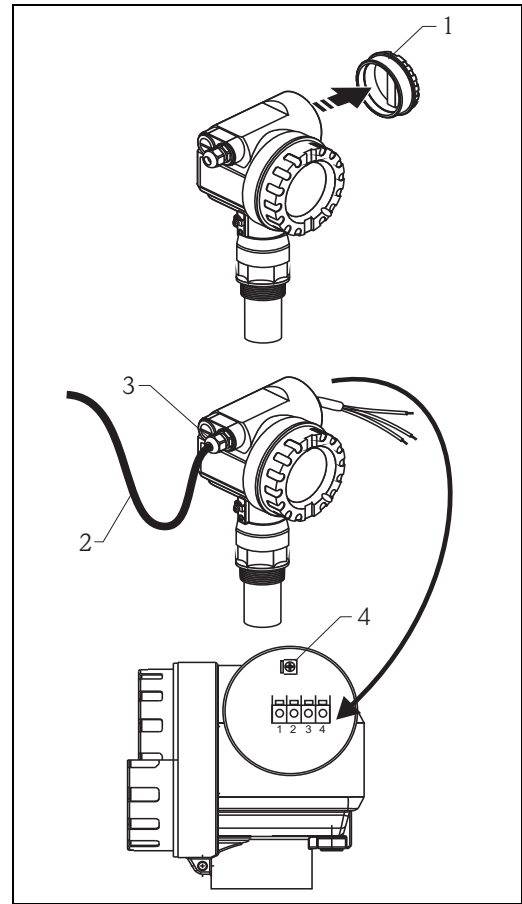

L00-FM14xxxx-04-00-00-yy-009

4.1.3 Terminal assignment

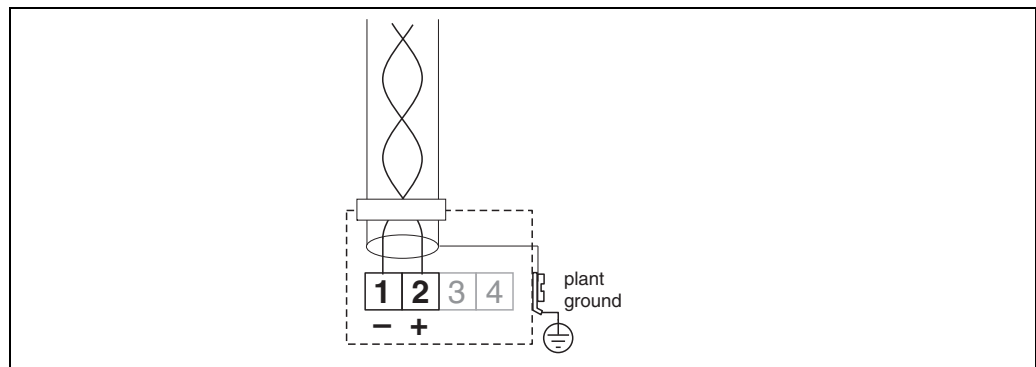

L00-FMxxxxx-04-00-00-en-013

4.2 Wiring with FOUNDATION Fieldbus plug

1. Insert plug (1) into bushing (2).
2. Screw firmly.
3. Ground instrument according to the desired safety concept.

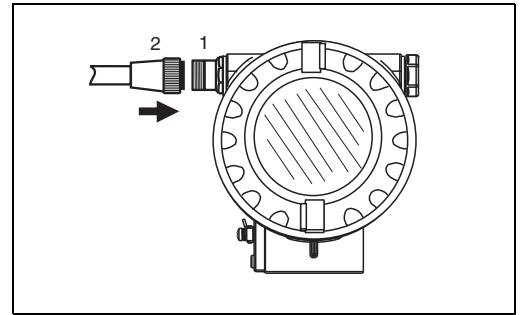

L00-FMU4xxxx-04-00-00-yy-011

4.2.1 Pin assignment of the 7/8" plug connector (FOUNDATION Fieldbus plug)

	Pin	Meaning
	1	FF -
	2	FF +
	3	not connected
	4	ground

L00-FMxxxxxx-04-00-00-yy-017

4.3 Cable specifications FOUNDATION Fieldbus

Twisted, shielded pairs must be used. The cable specifications can be taken from the FF specification or IEC 61158-2. The following have been found suitable:

Non-Ex-area:

- Siemens 6XV1 830-5BH10,
- Belden 3076F,
- Kerpen CEL-PE/OSCR/PVC/FRLA FB-02YS(ST)YFL.

Ex-area:

- Siemens 6XV1 830-5AH10,
- Belden 3076F,
- Kerpen CEL-PE/OSCR/PVC/FRLA FB-02YS(ST)YFL.

4.4 Supply voltage

The following values are the voltages across the terminals directly at the instrument:

Type	Minimum terminal voltage	Maximum terminal voltage
standard	9 V	32 V
Ex ia (FISCO model)	9 V	17,5 V
Ex ia (Entity concept)	9 V	24 V

The current consumption is approx. 15 mA for the range of voltages given above.

4.5 Recommended connection

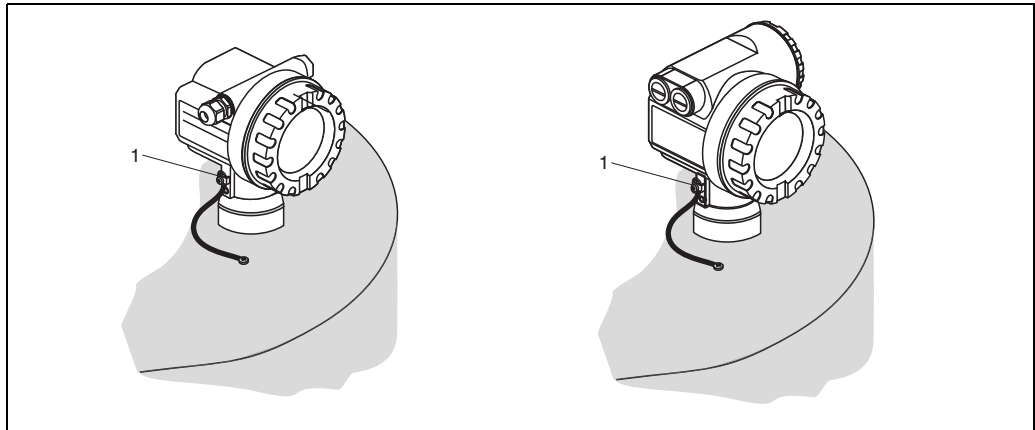

L00-FMU4xxxx-17-00-00-yy-014

1 External ground terminal of the transmitter

For maximum EMC protection please observe the following points:

- As the metal housing of the Prosonic M is isolated from the tank by the plastic sensor, a low-impedance connection between the housing and tank/bracket/flange should be installed in order to ensure electromagnetic compatibility (EMC).
For optimum EMC the connection should be as short as possible. Ideally, a ground strap should be used.
- The continuity of the cable screening between tapping points must be ensured.
- If potential equalisation is present between the individual grounding points, ground the screening at each cable end or connect it to the device housing (as short as possible).
- If there are large differences in potential between grounding points, the grounding should run via a capacitor that is suitable for high frequency use (e.g. ceramic 10 nF/250 V~).



Caution!

Applications, which are subject to the explosion prevention, permit only under special conditions the repeated grounding of the protective screen, see to EN 60 079-14..

4.6 Post connection check

After wiring the device, carry out the following checks:

- Are the terminals correctly assigned?
- Is the cable gland tight?
- If available: Is the FOUNDATION Fieldbus connector screwed tight?
- Is the housing cover fully screwed on?
- If power supply available: Does a display appear on the display module?

5 Operation

5.1 Operation with the display and operating module VU331

The LCD module VU331 for display and operation is located beneath the housing cover. The measured value is legible through the glass in the cover. Open the cover to operate the device.

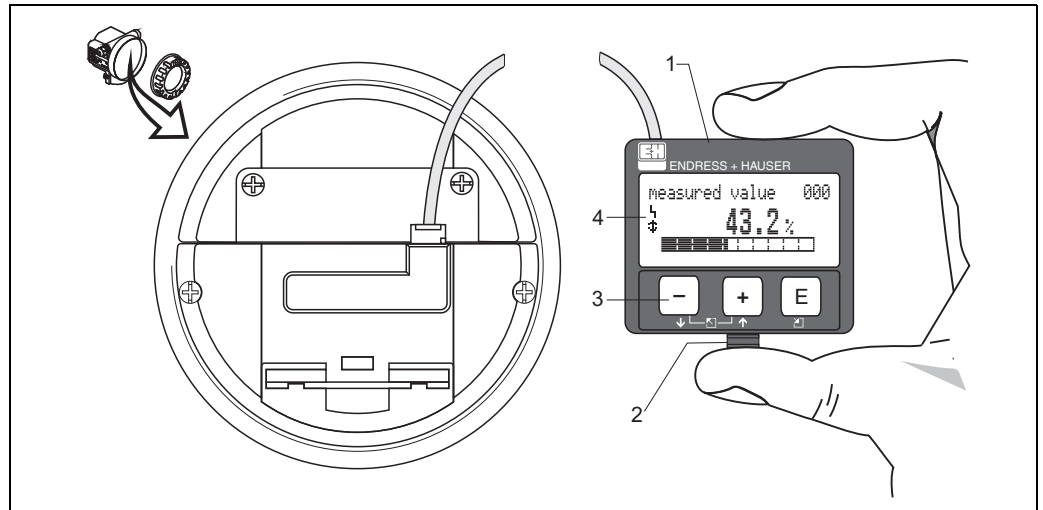

- 1 LCD liquid crystal display
- 2 Snap fit
- 3 Keys
- 4 Symbols

100-FMxxxxx-07-00-00-yy-001

5.1.1 Display appearance

<p>measured value display</p>	<ol style="list-style-type: none"> 1. label 2. symbol 3. value 4. bargraph 5. unit 6. position in menu
<p>group selection</p>	<ol style="list-style-type: none"> 1. selection list
<p>Function with free parameter</p>	<ol style="list-style-type: none"> 1. label 2. help texts 3. position in menu
<p>envelope curve</p>	<ol style="list-style-type: none"> 1. envelope curve















In the measured value display, the bargraph corresponds to the output. The bargraph is segmented in 10 bars. Each completely filled bar represents a change of 10% of the adjusted span.

5.1.2 Display symbols

The following table describes the symbols that appear on the liquid crystal display:

Sybmol	Meaning
	ALARM_SYMBOL This alarm symbol appears when the instrument is in an alarm state. If the symbol flashes, this indicates a warning.
	LOCK_SYMBOL This lock symbol appears when the instrument is locked,i.e. if no input is possible.
	COM_SYMBOL This communication symbol appears when a data transmission via e.g. HART, PROFIBUS PA or FOUNDATION Fieldbus is in progress.
	SIMULATION_SWITCH_ENABLE This communication symbol appears when simulation in FOUNDATION Fieldbus is enabled via the DIP switch.

5.1.3 Function of the keys

Key(s)	Meaning
 or 	Navigate upwards in the selection list Edit numeric value within a function
 or 	Navigate downwards in the selection list Edit numeric value within a function
  or 	Navigate to the left within a function group
	Navigate to the right within a function group, confirmation.
 and  or  and 	Contrast settings of the LCD
 and  and 	Hardware lock / unlock After a hardware lock, an operation of the instrument via display or communication is not possible! The hardware can only be unlocked via the display. An unlock parameter must be entered to do so.

5.2 Function codes

For easy orientation within the function menus, for each function a position is shown on the display.

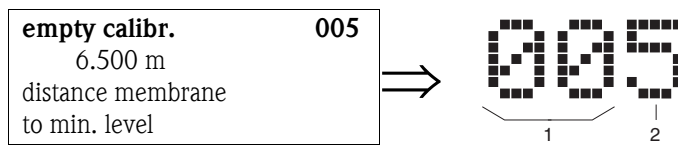

- 1 Function group
- 2 Function

The first two digits identify the function group:

- basic setup 00
- safety settings 01
- linearisation 04

...

The third digit numbers the individual functions within the function group:

- basic setup 00 → ■ tank shape 002
- medium property 003
- process cond. 004

...

Hereafter the position is always given in brackets (e.g. "tank shape" (002)) after the described function.

5.3 Operating options

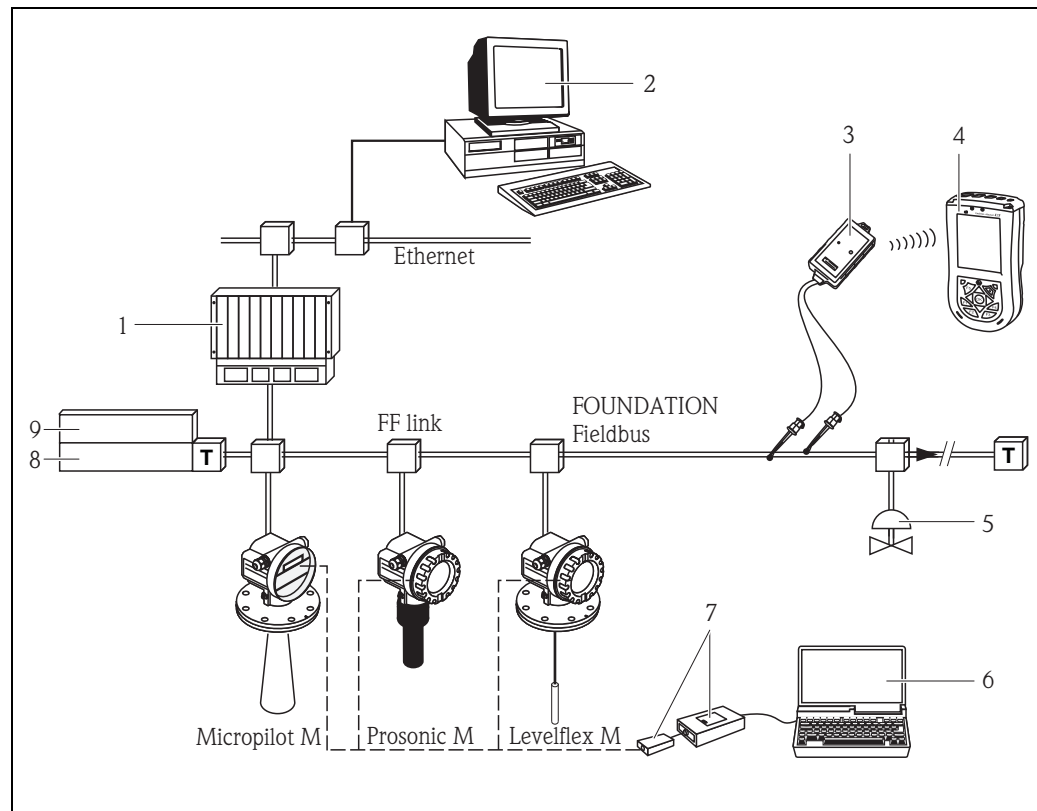

L00-FMxxxxx-14-00-06-yy-031

- 1 SPS, PLC, API
- 2 Personal computer, e.g. with NI-FBUS configurator
- 3 VIATOR Bluetooth-Modem with connection cable
- 4 Field Xpert SFX100
- 5 More functions (valves etc.)
- 6 FieldCare
- 7 Commubox FXA291 with ToF Adapter FXA291
- 8 Power conditioner
- 9 Power supply

5.4 On-site operation

5.4.1 Options for on-site operation

- Display and operating module VU331
- Endress+Hauser operating software "FieldCare"

5.4.2 Parameter access by on-site operation

The following parameters can be accessed by on-site operation:

- Parameters of the device specific blocks (Sensor Block, Diagnostic Block, Display Block)
- Endress+Hauser service parameters
- In the Resource Block: "Device Tag", "Device ID", "Device Revision", "DD Revision" (read only)

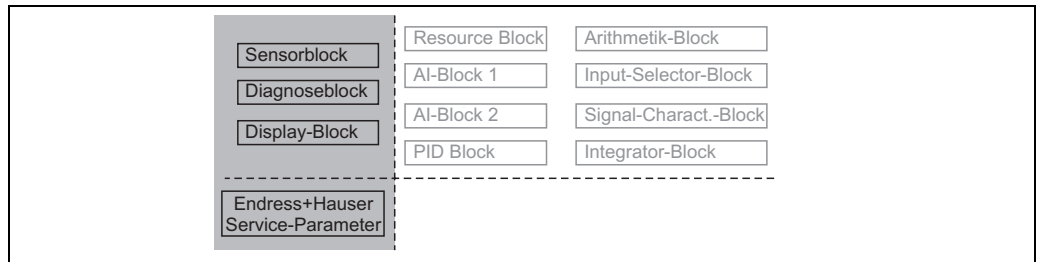

L00-FMU4XXXX-02-00-00-YY-005

The highlighted parameters can be edited by on-site operation.

5.5 Operation using the on-site display VU331

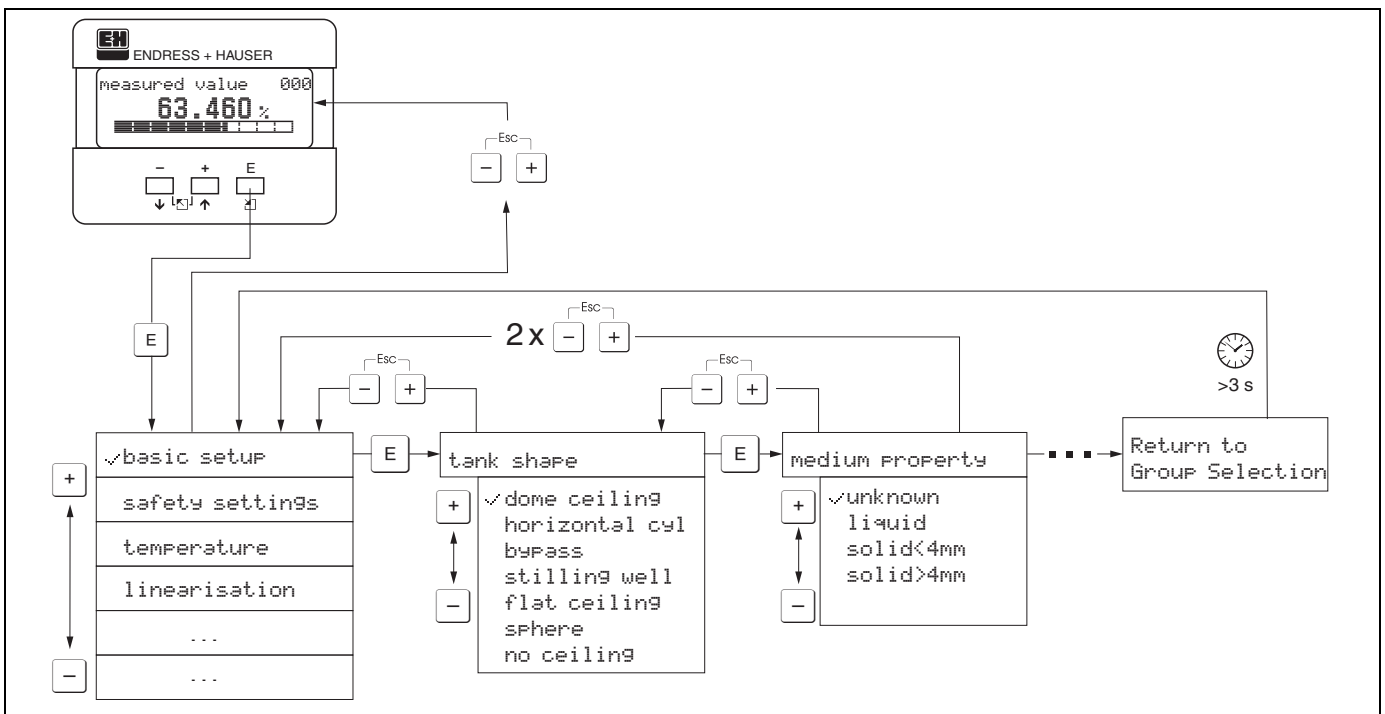

L00-FMU4xxxx-19-00-00-en-018

1. Change from Measured Value Display to **Group Selection** by pressing **E**.
2. Press **-** or **+** to select the required **Function Group** and confirm by pressing **E**. The active selection is marked by a **_** in front of the menu text.
3. Activate Edit mode with **+** or **-**.

Selection menus

- a. Select the required **Parameter** in selected **function** with **-** oder **+**.
- b. **E** confirms selection; **_** appears in front of the selected parameter.
- c. **E** confirms the edited value; system quits edit mode.
- d. **+** and **-** (= **Esc**) interrupts selection; system quits edit mode.

Typing in numerals and text

- a. Press **+** or **-** to edit the first character of the **numeral / text**.
- b. **E** positions the cursor at the next character; continue with a. until you have completed your input.

- c. If a ↵ symbol appears at the cursor, press **[E]** to accept the value entered; system quits edit mode.
 - d. If a ← symbol appears at the cursor, press **[E]** to return to the previous character (e.g. for correction of entries).
 - e. **[+]** and **[-]** (= **[↵]**) interrupts selection; system quits edit mode.
4. Press **[E]** to select the next **function**.
 5. Press **[+]** and **[-]** (= **[↵]**) once; return to previous **function**.
Press **[+]** and **[-]** (= **[↵]**) twice; return to **Group Selection**.
 6. Press **[+]** and **[-]** (= **[↵]**) to return to **Measured value display**.

5.6 Remote operation

5.6.1 Options for remote operation

- FOUNDATION Fieldbus configuration tool (e.g. DeltaV or ControlCare)
- Handheld terminal Field Xpert SFX100

5.6.2 Parameter access by remote operation

The following parameters can be accessed by remote operation:

- Parameters of the device specific blocks (Sensor Block, Diagnostic Block, Display Block)
- Parameters of the FOUNDATION Fieldbus function blocks

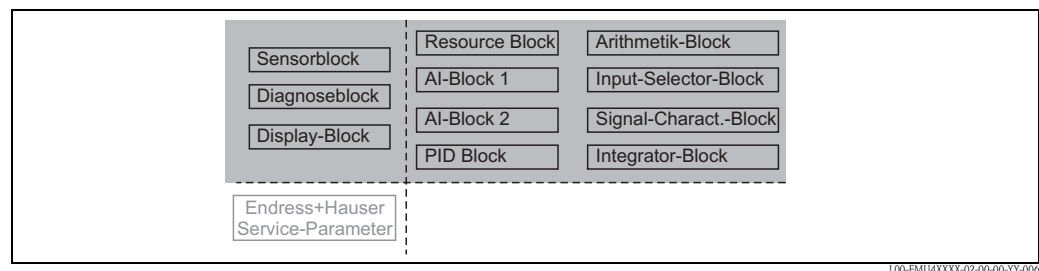

The highlighted parameters can be edited by remote operation.

L00-FMU4XXXX-02-00-00-YY-000

5.7 FieldCare operating program

FieldCare is an Endress+Hauser asset management tool based on FDT technology. With FieldCare, you can configure all Endress+Hauser devices as well as devices from other manufacturers that support the FDT standard. Hardware and software requirements you can find on the internet: www.endress.com → select your country → search: FieldCare → FieldCare → Technical Data.

FieldCare supports the following functions:

- Configuration of transmitters in online operation
- Singal analysis via envelope curve
- Tank linearisation
- Loading and saving device data (upload/download)
- Documentation of the measuring point

Connection options:

- HART via Commubox FXA195 and the USB port on a computer
- Commubox FXA291 with ToF Adapter FXA291 (USB) via service interface

5.7.1 Menu-guided commissioning:

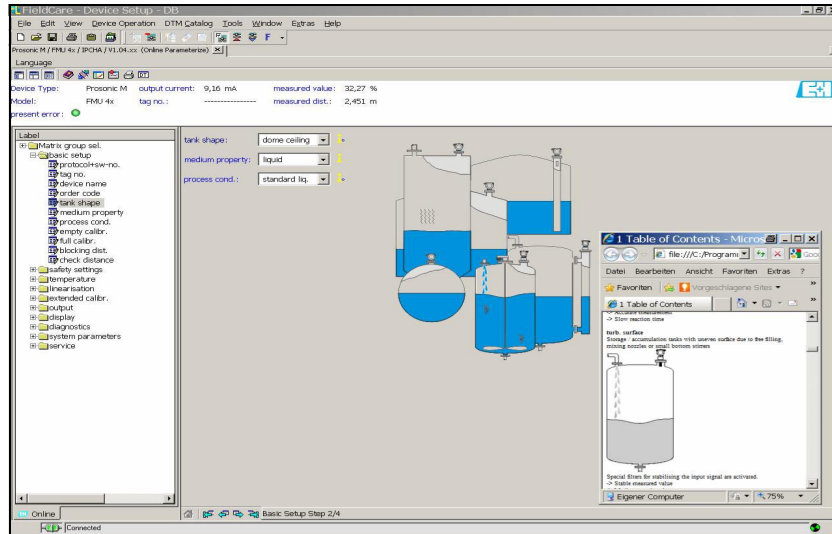

L00-FMU4xxxx-19-00-00-en-021

- You can find the function groups and functions of the device in the **navigation bar**.
- You can find the input fields for the parameters in the **main window**.
- If you click on a parameter name, the **Help pages** open with precise explanations of the required input.

5.7.2 Signal analysis via envelope curve:

The FieldCare offers easy analysis of the envelope curve via the "Envelope" menu:

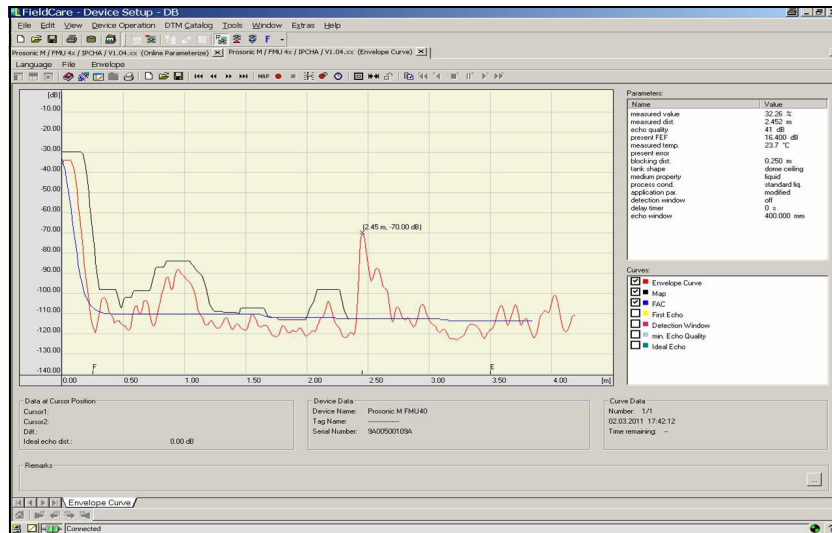

L00-FMU4xxxx-19-00-00-en-022

5.8 Operation with a FOUNDATION Fieldbus configuration program

5.8.1 FOUNDATION Fieldbus configuration programs

The user can obtain special configuration and operating programs offered by different manufacturers for use in configuration. These can be used for configuring both the FOUNDATION Fieldbus functions and all the device-specific parameters. The predefined function blocks allow uniform access to all the network and fieldbus device data.

5.8.2 Device Description files

File names

You will need the following files for commissioning and network configuration:

- **Device Description files:** *.sym, *.ffo
These files describe the structure of the blocks and their parameters. They offer guided setups with the help of menus and methods.
- **Capability file:** *.cff
This file enables offline configuration and describes the device capability in terms of communication stack and function blocks.

The file names consist of the following parts:

- Device Revision (OC3)¹⁾
- DD Revision (OC4)¹⁾ (use the most current version)
- CFF Revision (use the most current version)

Example:

- Device Revision (OC3) = 03
- DD Revision (OC4) = 01
- CFF Revision = 02
- -> files to be used: "0301.sym", "0301.ffo", "030102.cff"

Directory structure

The files are normally stored in the following directory structure:

- /452B48/1011/*
 *.sym
 *.ffo
 *.cff

The directory names have the following meaning:

- 452B48: manufacturer ID of Endress+Hauser
- 1011: device ID of Prosonic M

1) "Device Revision" (OC3) and "DD Revision" (OC4) can be obtained through the display and operating module VU331. For details refer to section 5.2: "Operation with the display and operating module VU331"

Source of supply

Host System	Source of supply for the Device Description and Network Configuration files
ABB (Field Controller 800) Allen Bradley (Control Logix) Endress+Hauser (ControlCare) Honeywell (Experion PKS) Invensys SMAR (System 302)	<ul style="list-style-type: none"> ■ www.endress.de (-> Download -> Media type = "Software", "Device Drivers") ■ CD-ROM (Endress+Hauser order code: 56003896) ■ www.fieldbus.org
Emerson (Delta V)	<ul style="list-style-type: none"> ■ www.easydeltav.com
Yokogawa (CENTUM CS 3000)	<ul style="list-style-type: none"> ■ www.yokogawa.com

5.8.3 Representation of parameters

A FOUNDATION Fieldbus configuration tool offers two types of parameter representation:

- **Representation by parameter name**

Examples: "PAROPERATIONCODE", "PARRESET"

- **Representation by parameter label**

(identical to the labels on the display module VU331 and in an Endress+Hauser operation tool)

Examples: "unlock parameter", "reset"

5.9 Operation via Field Xpert SFX100

Compact, flexible and robust industry handheld terminal for remote parametrization and measured value inspection via the HART current output or FOUNDATION Fieldbus. For details refer to Operating Instructions BA00060S/04/EN.

6 Commissioning

This chapter consists of the following sections:

- 6.1 Function check → 40
- 6.2 Unlocking the device → 40
- 6.3 Parameter reset → 42
- 6.4 Commissioning with display and operating module VU331 → 44
- 6.5 Commissioning with FOUNDATION Fieldbus configuration tool → 55

6.1 Function check

Make sure that all final checks have been completed before you start up your measuring point:

- Checklist "Post installation check" (→ 26).
- Checklist "Post connection check" (→ 30).

6.2 Unlocking the device

Before commissioning, make sure that the device is not locked against parameter changes. On delivery, the device is unlocked. In other cases, however, it may have been locked in one of the following ways:

6.2.1 DIP switch (under the housing cover)

Locking and unlocking

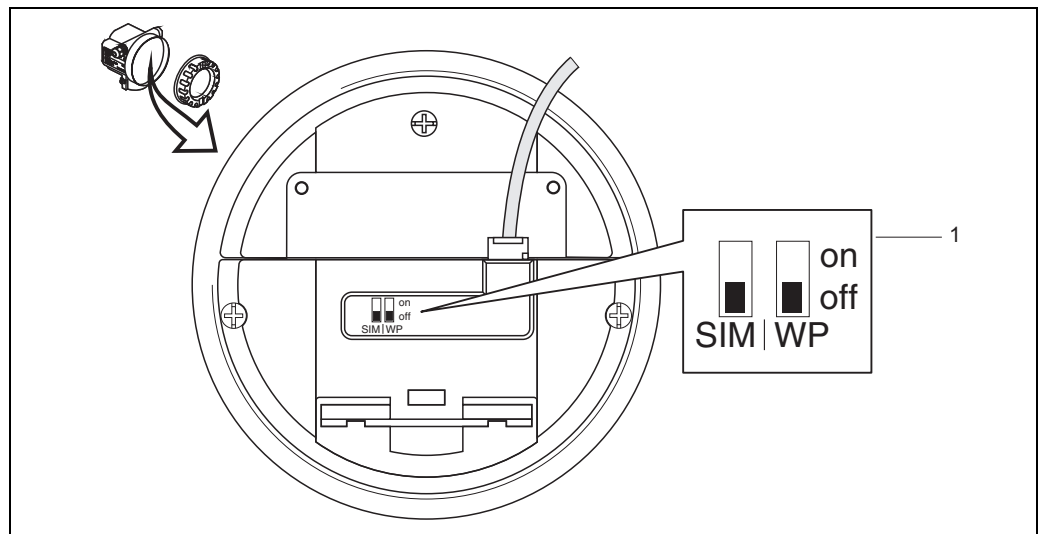

1 Default settings: SIM = off (simulation); WP = off (write protection)

WP = on: parametrization locked

WP = off: parametrization unlocked

SIM = on: simulation possible in Analog Input Block by configuration tool

SIM = off: simulation not possible in Analog Input Block by configuration tool

Parameters affected

Locking by the DIP switch affects **all** parameters.

6.2.2 Key combination (display and operating module VU331)

Locking

Press ,  and  simultaneously.

Unlocking

If you try to change a parameter, the following appears:

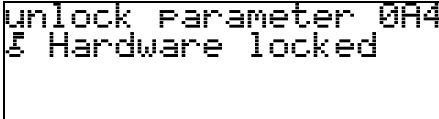

L00-fmrxl0a4-20-00-00-de-001

Press ,  and  simultaneously. The **"unlock parameter" (0A4)** function appears. Enter "2457". Now parameters can be changed.

Parameters affected

Locking by the key combination affects the following parameters:

- Parameters of the device specific blocks (Sensor Block, Diagnostic Block, Display Block)
- Endress+Hauser service parameters

6.2.3 Locking parameter

Locking

Enter a number other than "2457" into the **"unlock parameter" (0A4)** function. (FOUNDATION Fieldbus: Diagnostic Block, parameter PAROPERATIONMODE)

Unlocking

Enter **"2457"** into the **"unlock parameter" (0A4)** function. (FOUNDATION Fieldbus: Diagnostic Block, parameter PAROPERATIONMODE)

Parameters affected

Locking by the locking parameter affects the following parameters:

- Parameters of the device specific blocks (Sensor Block, Diagnostic Block, Display Block)
- Endress+Hauser service parameters

6.3 Resetting the device

It is advisable to reset the device parameters before the commissioning if you want to use a device with an unknown history.



Note!

5-point linearity protocol

The specified measuring accuracy is a typical value → 79, "Performance characteristics".

With the production of the 5-point linearity protocol the measuring system (sensor and electronic) is adjusted exactly to one another and the measuring accuracy is optimized for the specified range. To realize this, the parameter "zero distance" is fine adjusted. After a reset the value for the zero distance has to be re-parameterized in the service menu according to the data on the associated 5-point linearity protocol. Please contact the Endress+Hauser service.

6.3.1 Resetting the parameters of the FOUNDATION Fieldbus function blocks

Parameters affected

- all parameters of the FOUNDATION Fieldbus function blocks

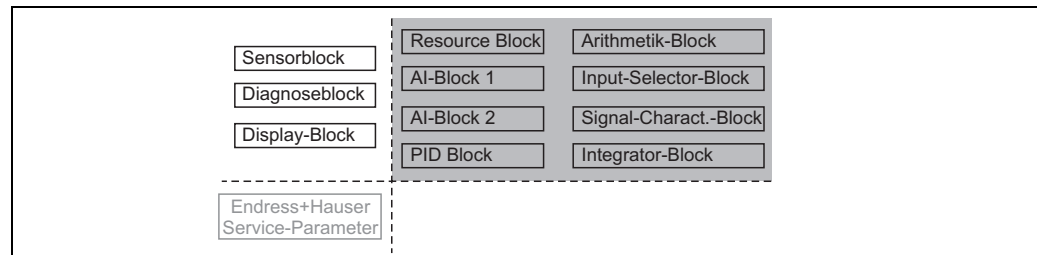

100-FMU4XXXX-02-00-00-YY-007

Performing the reset

Resource Block, parameter RESTART; select the option "defaults".

6.3.2 Resetting the parameters of the transducer blocks



Caution!

A reset may lead to impairment of the measurement. As a rule, a basic calibration is required after a reset.



Note!

The default values of each parameter are shown in bold in the menu overview in the appendix.

In order to carry out the reset, enter the number "33333" in the **"reset" (0A3)** function in the **"diagnostics" (0A)** function group. (FOUNDATION Fieldbus: **Diagnostic Block**, Parameter **PARRESET (reset)**)

Parameters affected

- all parameters of the device specific blocks (Sensor Block, Diagnostic Block, Display Block)

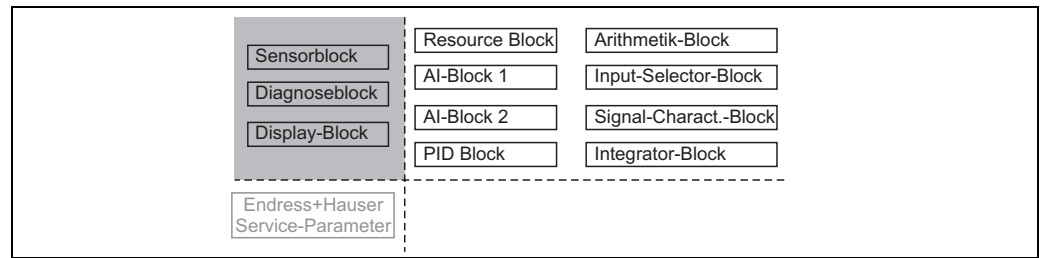

Effects of the reset

- All customer parameters are reset to their default values.
- Customer interference echo suppression is **not** deleted.
- Linearisation is switched to **"linear"**, but the table values are kept. The table can be switched back on in the **"linearisation" (04)** function group in the **"linearisation" (041)** function. (FOUNDATION Fieldbus: Sensor Block, Parameter PARLINEARISATION (linearisation))

Performing the reset

"diagnostics" (0A) function group, "reset" (0A3) function; enter "33333"
(FOUNDATION Fieldbus: Diagnostic Block, parameter PARRESET)

6.3.3 Resetting an interference echo suppression (tank map)

It is always advisable to reset the interference echo suppression (tank mapping) when:

- a device with an unknown history is used
- an incorrect suppression was input

Resetting the tank map with the VU331

1. In the **"extended calibr." (05)** function group select the **"selection" (050)** function.
2. Select **"extended map."**
3. Go to the **"cust. tank map" (055)** function and select the required option:
 - **"reset"**: deletes the existing tank map.
 - **"inactive"**: deactivates the tank map but does not delete it. It can be re-activated when required.
 - **"active"**: activates the tank map.

Resetting the tank map with an Endress+Hauser operating program

1. In the function group **"extended calibr."** select the **"cust. tank map" (055)** function.
2. Select the required option (**"reset"**, **"inactive"** or **"active"**)

Resetting the tank map with a FOUNDATION Fieldbus configuration tool

1. In the **Sensor Block** select the parameter **PARCUSTTANKMAP (cust tank map)**.
2. Select the required option (**"reset"**, **"inactive"** or **"active"**).

6.4 Commissioning by the display and operating module VU331

6.4.1 Power up instrument

After switching on the supply voltage, the instrument is first initialised. Then the following appear for approximately five seconds:

- Device type
- Software version

Press E to exit this display.

On first power-up, you are requested to select the language for the display texts. Available language:

- English
- Deutsch
- Français
- Español
- Italiano
- Nederlands
- Japanese

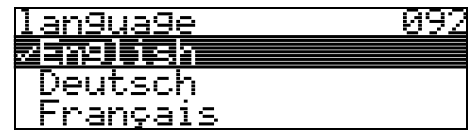

Then you are requested to select the unit of length for your measurements. Available unit of length:

- m
- ft
- mm
- inch

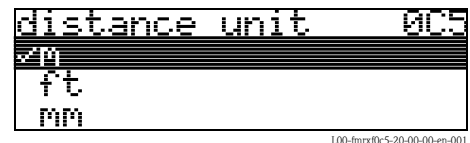

A measured value is displayed. This is NOT equivalent to the level in your tank. Firstly carry out a basic calibration.

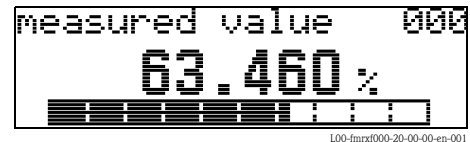

Press **E** to switch to the group selection.
Press **E** again to start the basic calibration.



6.4.2 Basic setup

The "Basic setup" (00) function group lists all the functions which are required for a standard measurement task to commission the Prosonic M. When you have completed your input for a function, the next function appears automatically. In this way, you are guided through the complete calibration.

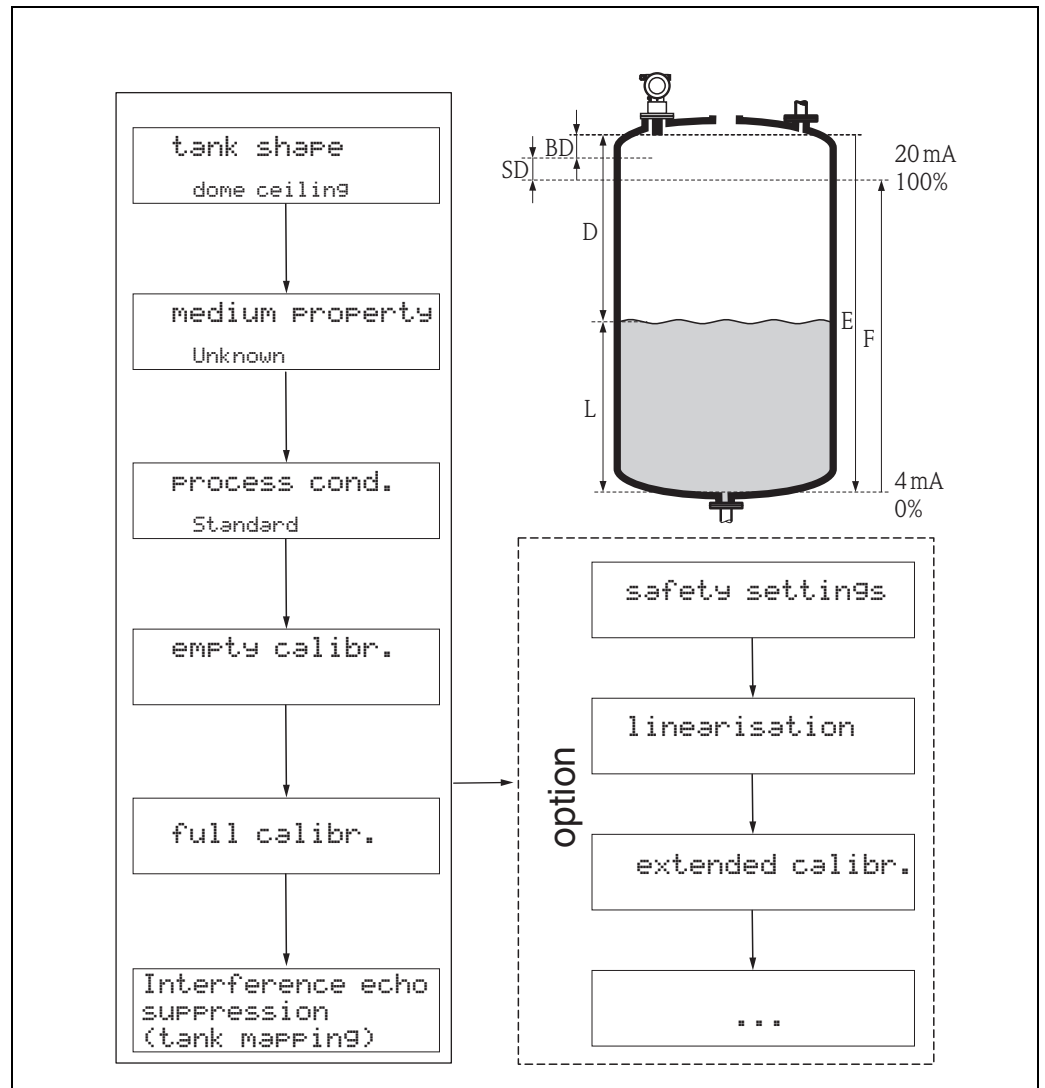

- D* Distance (distance from the sensor membrane (= reference point of the measurement) / product)
- E* Empty calibr. (= zero point)
- F* Full calibr. (= span)
- L* Level
- BD* Block distance
- SD* Safety distance

6.4.3 Application parameters

Function "tank shape" (002)

In this function, select one of the following options:

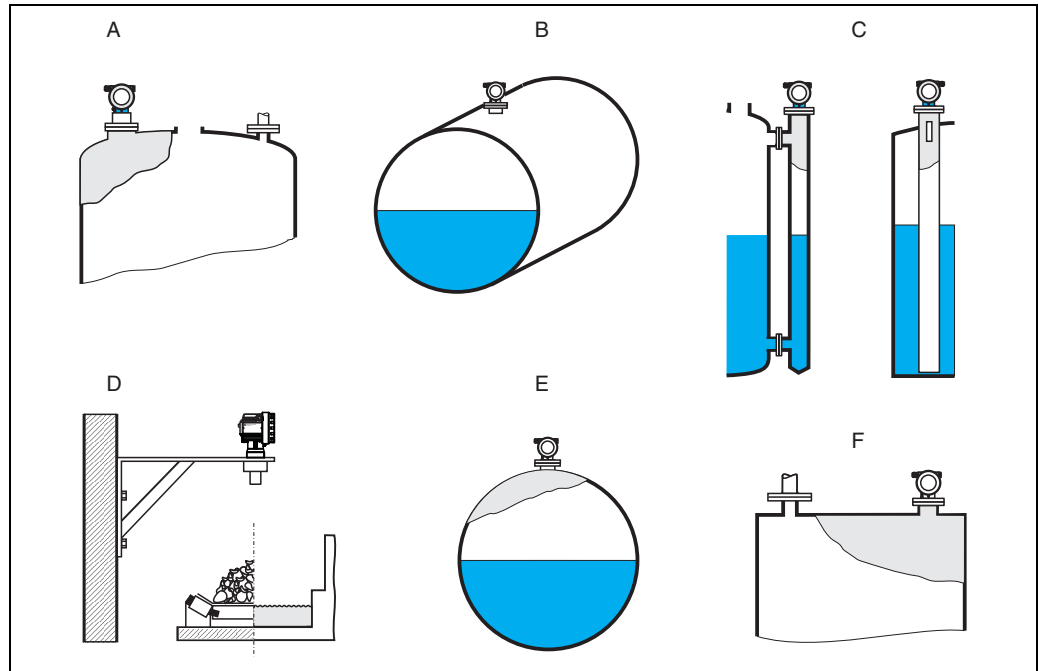

- A* Dome ceiling
B Horizontal cyl
C Bypass, stilling well/ultrasonic guide pipe
D No ceiling, e.g. dumps, open levels, chanel, weirs
E Sphere
F Flat ceiling

Function "medium property" (003)

Set the medium type in this function.

You have the following options:

- unknown (e.g. pasty media such as greases, creams, gels etc.)
- liquid
- solid, grain size < 4mm, (fine)
- solid, grain size > 4mm, (coarse)

Function "process conditions" (004)

For this function, you have the following options:

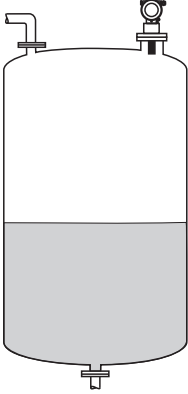
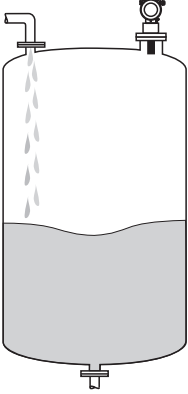
standard liquids	calm surface	turb. surface
For all fluid applications which do not fit in any of the following groups.	Storage tanks with immersion tube or bottom filling	Storage / accumulation tanks with uneven surface due to free filling, mixing nozzles or small bottom stirrers
	 <p style="text-align: center; font-size: small;">L00-FMU4xxxx-14-00-00-xx-001</p>	 <p style="text-align: center; font-size: small;">L00-FMU4xxxx-14-00-00-xx-002</p>
The filters and output damping are set to average values.	The averaging filters and output damping are set to large values. -> Stable measured value -> Accurate measurement -> Slow reaction time	Special filters for stabilising the input signal are activated. -> Stable measured value -> Medium reaction time

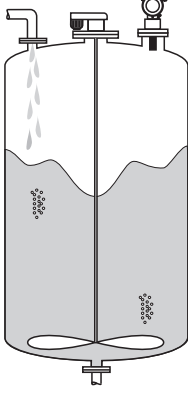
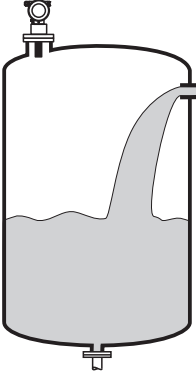
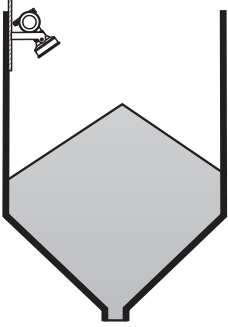
add. agitator	fast change	standard solid
Moving surfaces (poss. with vortex formation) due to agitators	Rapid level change, particularly in small tanks	For all bulk solids applications which do not fit in any of the following groups.
 <p style="text-align: center; font-size: small;">L00-FMU4xxxx-14-00-00-xx-003</p>	 <p style="text-align: center; font-size: small;">L00-FMU4xxxx-14-00-00-xx-004</p>	 <p style="text-align: center; font-size: small;">L00-FMU4xxxx-14-00-00-xx-006</p>
Special filters for stabilising the input signal are set to large values. -> Stable measured value -> Medium reaction time	The averaging filters are set to small values. -> Rapid reaction time -> Possibly unstable measured value	The filter and output damping are set to average values.

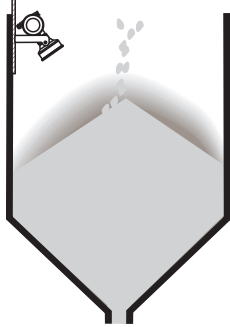
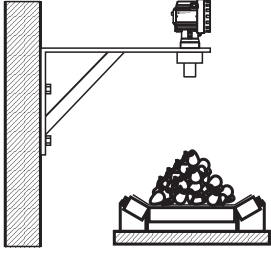
solid dusty	conveyor belt	Test: no filter
<p>Dusty bulk solids</p>	<p>Bulk solids with rapid level change</p>	<p>All the filters can be switched off for purposes of service and diagnosis.</p>
 <p style="text-align: center; font-size: small;">L00-FMU4xxxx-14-00-00-xx-007</p>	 <p style="text-align: center; font-size: small;">L00-FMU4xxxx-14-00-00-xx-005</p>	
<p>The filters are set to detect even relatively weak signals.</p>	<p>The averaging filters are set to small values. -> Rapid reaction time Possibly unstable measured value</p>	<p>All filters off</p>

6.4.4 Empty and full calibration

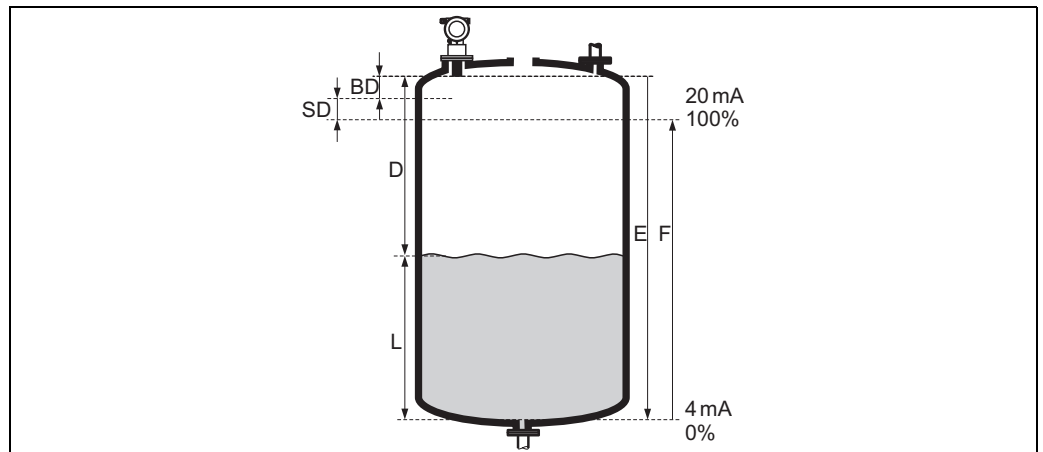

BD Blocking distance

SD Safety distance

E Empty calibration (= zero point)

F Full calibration (= span)

D Nozzle diameter

L Level

L00-FMU4xxxx-19-00-00-yy-019

Function "empty calibration" (005)

In this function, enter the distance *E* from the sensor membrane to the minimum level (zero point).



Caution!

With dished boiler heads or conical outflows, the zero point should not be deeper than the point at which the ultrasonic wave impinges on the tank bottom.

Function "blocking distance" (059)

In this function the blocking distance (*BD*) of the sensor is displayed.



Caution!

When entering the full calibration (span), please take into account, that the maximum level may not project into the blocking distance (*BD*)



Note!

After basic calibration, enter a safety distance (*SD*) in the "**safety distance**" (015) function. If the level is within this safety distance, the Prosonic M signals a warning or an alarm, depending on your selection in the "**in safety distance**" (016) function.

Function "full calibration" (006)

In this function, enter the span *F*, i.e. the distance from the minimum level to the maximum level.

6.4.5 Interference echo suppression (tank mapping)

Function "dist./measured value" (008)

In the "dist./meas.value" (008) function, the measured distance D from the sensor membrane to the product surface is displayed together with level L. Check these values.

Function "check distance" (051)

The mapping is initialized by this function.

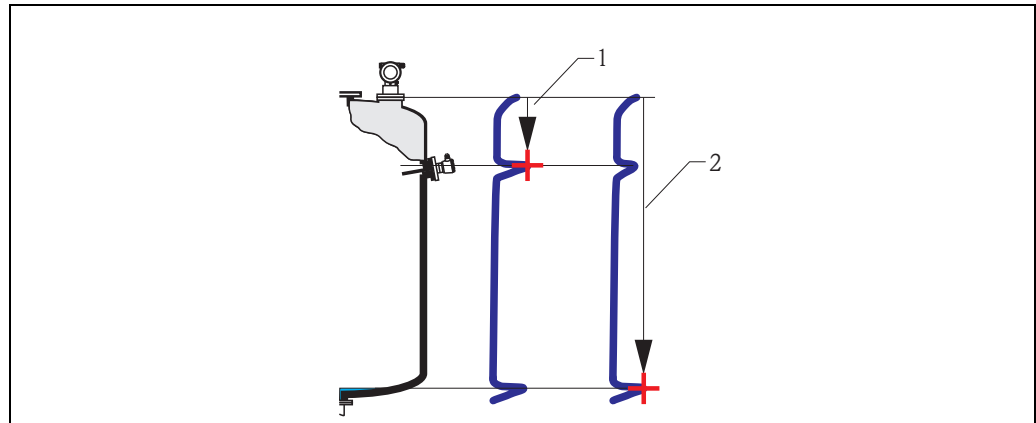

- 1 Distance too small
2 Distance = ok

Select

- **"distance=ok"** if the correct distance is displayed. Any echoes closer to the sensor will be suppressed by the following interference echo suppression.
- **"dist. too small"** if the displayed distance is too small. In this case, the signal comes from an interference echo which will be suppressed.
- **"dist. too big"** if the displayed distance is too large. This error cannot be cancelled by suppressing the interference echo. This means that the following two functions are skipped. Check the application parameters **"tank shape" (002)**, **"medium proerty" (003)** and **"process cond." (004)** and the **"empty calibr."(005)** in the **"basic setup" (00)** function group.
- **"dist. unknown"** if you do not know the actual distance. This means that the following two functions are skipped.
- **"manual"** if you want to specify the suppression area yourself in the following function.

Function "range of mapping" (052)

The suggested suppression area is displayed in this function. The reference point is always the sensor membrane. You can still edit the value. With manual suppression, the default value is 0 m.



Caution!

The suppression range must end 0.5 m (1.6 ft) in front of the echo of the actual level. With an empty tank, do not enter E but E - 0.5 m.

Function "start mapping" (053)

You have the following options for this function:

- **off:** Nothing is suppressed.
- **on:** Starts suppression.



Note!

If a mapping already exists, it will be overwritten up to the distance specified in the "**range of mapping**" (052) function. Beyond this distance the existing mapping remains unchanged.

Function dist./measured value (008)

After suppression, the measured distance D from the sensor membrane to the product surface is displayed together with the level. Check that the values correspond to the actual level and/or the actual distance.

The following cases may occur:

- Distance correct – Level correct -> End of basic calibration
- Distance incorrect – Level incorrect -> An additional interference echo suppression must be carried out. Go back to the "**check distance**" (051) function.
- Distance correct – Level incorrect -> Check the value of the "**empty calibr.**" (005) function.

Return to group selection

After the mapping has been recorded the basic calibration is completed and the device automatically returns to the group selection.

6.4.6 Envelope curve

After the basic setup, an evaluation of the measurement with the aid of the envelope curve ("envelope curve" (OE) function group) is recommended.

Function "plot settings" (OE1)

In this function, select whether you want to display

- Just the envelope curve
- The envelope curve and the echo evaluation line FAC
- The envelope curve and interference echo suppression (map)



Note!

The FAC and the interference echo suppression (map) are explained in BA00240F "Prosonic M - Description of Instrument Functions"

Function "recording curve" (OE2)

In this function, specify whether you want to display

- An individual envelope curve
- The current envelope curve, with cyclical refreshment.

Function "envelope curve display" (OE3)

The envelope curve is displayed in this function. You can use it to obtain the following information:

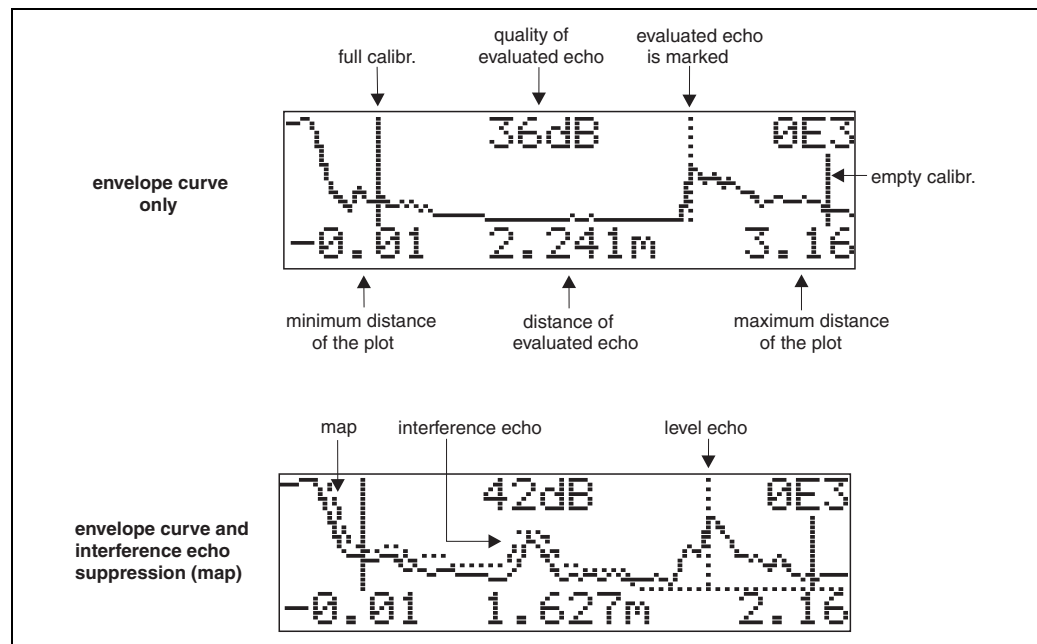

L00-FMU4xxxx-07-00-00-en-003

Check that the following conditions are fulfilled:

- The echo quality at the end of measuring range should be at least 10dB.
- There should be practically no interference echoes in front of the level signal.
- If interference echoes cannot be avoided, they must be below the suppression curve.



Note!

If the cyclical envelope curve display is still active on the display, the measured value is updated at a slower cycle time. We therefore advise you to exit the envelope curve display after optimising the measuring point. To do this, press \square . (The instrument does not leave the envelope curve display automatically.)

Navigation in the envelope curve display

Using navigation, the envelope curve can be scaled horizontally and vertically and shifted to the left or the right. The active navigation mode is indicated by a symbol in the top left hand corner of the display.

Horizontal Zoom mode:
 ☐☐ - horizontal zoom in
 ☐☐☐ - horizontal zoom out

Move mode:
 ☐☐☐ - moved to the left
 ☐☐☐☐ - moved to the right

Vertical Zoom mode:
 ☐0...☐3 - vertical zoom (4 steps)

100-FMxxxxxx-07-00-00-en-004

Horizontal Zoom mode

Firstly, go into the envelope curve display. Then press **[+]** or **[-]** to switch to the envelope curve navigation. You are then in Horizontal Zoom mode. Either ☐☐ or ☐☐☐ is displayed.

- **[+]** increases the horizontal scale.
- **[-]** reduces the horizontal scale.

100-FMxxxxxx-07-00-00-yy-007

Move mode

Then press **[E]** to switch to Move mode. Either ☐☐☐ or ☐☐☐☐ is displayed.

- **[+]** shifts the curve to the right.
- **[-]** shifts the curve to the left.

100-FMxxxxxx-07-00-00-yy-008

Vertical Zoom mode

Press **[E]** once more to switch to Vertical Zoom mode. ☐1 is displayed. You now have the following options.

- **[+]** increases the vertical scale.
- **[-]** reduces the vertical scale.

The display icon shows the current zoom factor (☐0 to ☐3).

100-FMxxxxxx-07-00-00-yy-009

Exiting the navigation

- Press **E** again to run through the different modes of the envelope curve navigation.
- Press **+** and **-** to exit the navigation. The set increases and shifts are retained. Only when you reactivate the "**recording curve**" (**OE2**) function the display settings return to their standard values.

6.5 Commissioning with a FOUNDATION Fieldbus configuration tool



Note!

For commissioning of the device with a FOUNDATION Fieldbus configuration tool you need to know the DEVICE_ID, which consists of the following parts:

Device_ID = 452B481011-XXXXXXX

whereby:

452B48	ID code for Endress+Hauser
1011	ID code for Prosonic M
XXXXXXX	Device serial number, as printed on the nameplate

6.5.1 First setup

1. Open the configuration tool and load the Device Descriptions (*.ffo, *.sym and - if required by the tool - *.cff). Ensure you use the correct files (→ 38, "Operation with a FOUNDATION Fieldbus configuration program").
2. The first time it is connected, the device reports as follows:

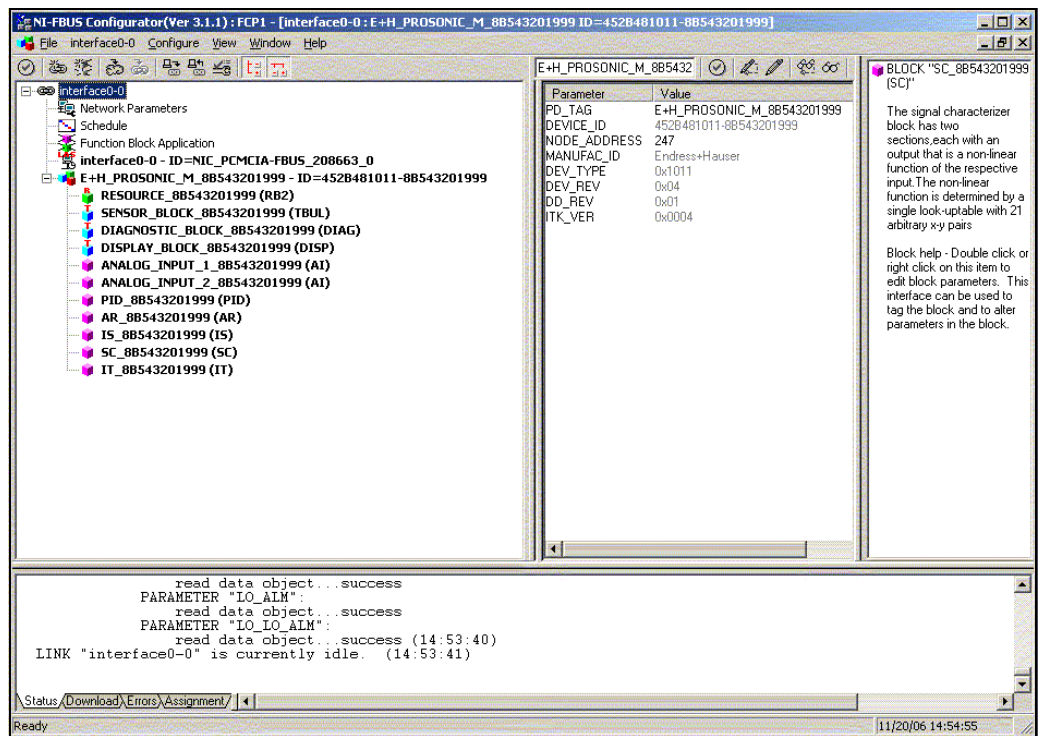

3. Identify the device using the DEVICE_ID and assign the desired field device tag name (PD_TAG).
Factory setting: PD_TAG = E+H_PROSONIC_M_XXXXXXX

6.5.2 Parametrization of the Resource Block (Start Index: 400)

1. Enter the desired block name (optional).
Factory setting: RESOURCE_XXXXXXXX
2. Open the Resource Block
3. On delivery, write protection is disabled so that you can access the write parameters via FOUNDATION Fieldbus. Check this status by the parameter WRITE_LOCK:
 - Write protection activated: WRITE_LOCK = LOCKED
 - Write protection deactivated: WRITE_LOCK = NOT LOCKED
 Deactivate the write protection if necessary, → 40.
4. Set the operating mode to AUTO in the parameter group MODE_BLK (parameter TARGET).

6.5.3 Parametrization of the Sensor Block (Start Index: 2000)

1. Enter the desired block name (optional).
Factory setting: SENSOR_XXXXXXXX
2. Open the Sensor Block. The following display appears:

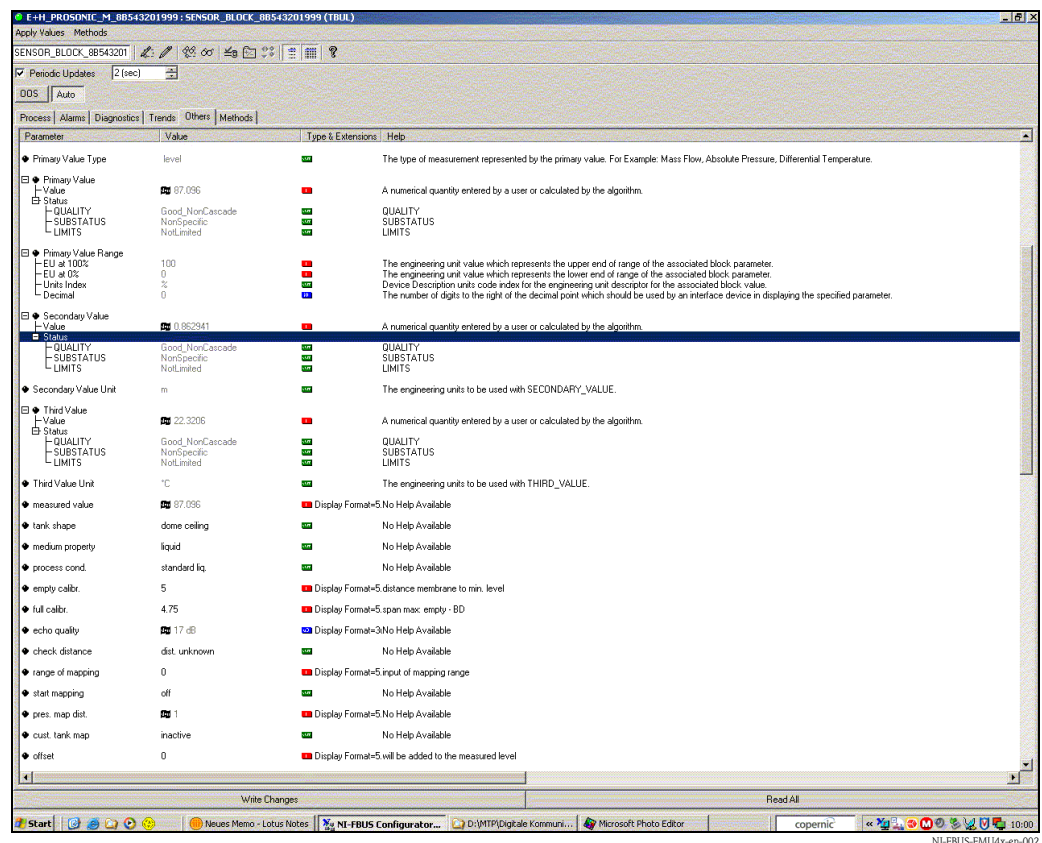

Hinweis!

There are two possibilities to edit the parameters of the block:

- A parameter from the list can be opened for editing by a double click.
- You can open one of the FOUNDATION Fieldbus methods. Each method guides you automatically through a number of parameters which are required for a specific configuration task. The following sections describe the parametrization by the "basic setup" method.

3. Open the FOUNDATION Fieldbus method "basic setup":

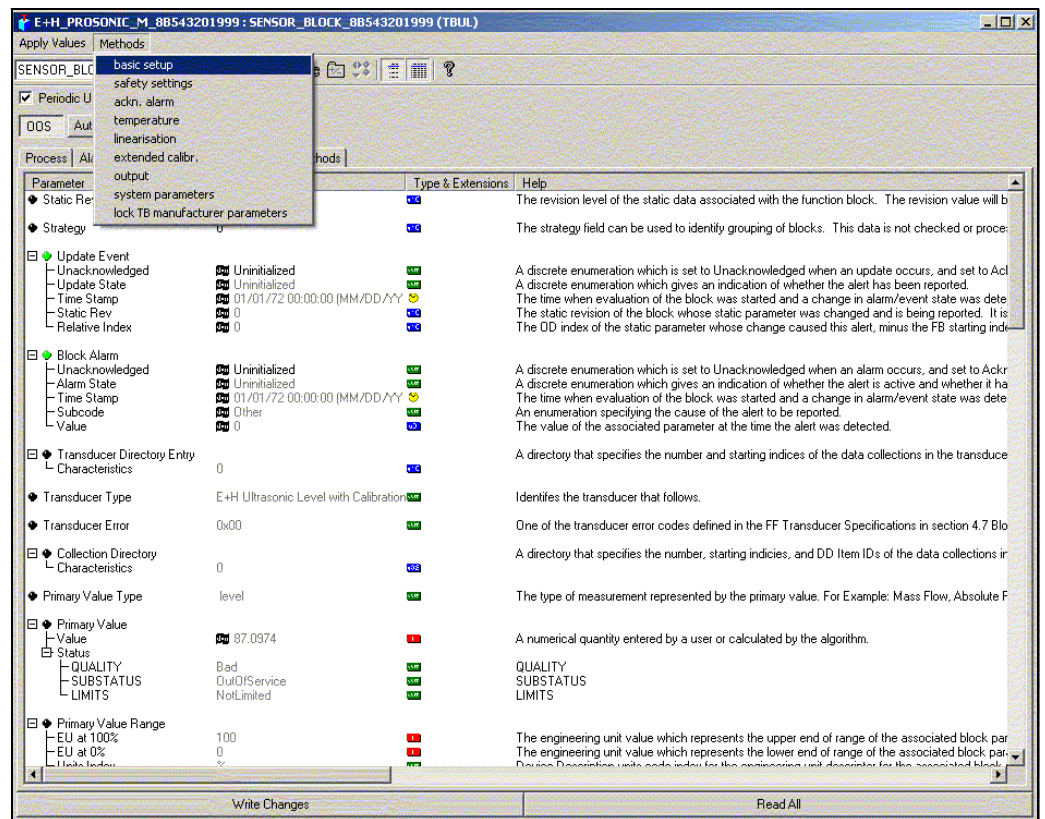

NI-FBUS-FMU4x-en-003

4. The method contains the following parameters²⁾:

- a. Application parameters (→ Chap. 6.4.3)
 - PARTANKSHAPE (tank shape)
 - PARMEDIUMCONDITION (medium property)
 - PARPROCESSCONDITION (process condition)
 - b. Empty and full calibration (→ Chap. 6.4.4)
 - PAREMPTYCALIBRATION (empty calibration)
 - PARFULICALIBRATION (full calibration)
 - c. Interference echo suppression (→ Chap. 6.4.5)
 - PARCHECKDISTANCE (check distance)
 - PARSUPPRESSIONDISTANCE (range of mapping)
 - PARSTARTMAPPINGRECORD (start mapping)
 - PARPRESMAPRANGE (pres. map. dist.)
 - PARCUSTTANKMAP (cust. tank map)
5. Set the operating mode to AUTO in the parameter group MODE_BLK (parameter TARGET). Otherwise the measured value can not be processed correctly by the connected Analog Input Block.
6. If measuring errors occur or if the measuring value seems unreliable, it is advisable to check the quality of the measurement by the envelope curve display. This can be done in two different ways:
- by the display and operating module VU331 (→ Chap. 6.4.1)
 - by an Endress+Hauser operating program (→ Chap. 6.5.1)

2) In the FOUNDATION Fieldbus configuration tool you can select from two types of parameter display:

- parameter names (e.g. "PARTANKSHAPE")
- label texts (e.g. "tank shape")

6.5.4 Parametrization of the Analog Input Blocks

Prosonic M has two Analog Input Blocks that can be assigned to the various process variables. The following description provides an example for the Analog Input Block 1 (Start Index 500).

1. Enter the desired block name (optional).
Factory setting: ANALOG_INPUT_1_XXXXXXX
2. Open the Analog Input Block.
3. Set the operating mode to OOS (Out of Service) in the parameter group MODE_BLK (parameter TARGET).
4. Using the parameter CHANNEL select the process variable that is to be used as the input value for the function block algorithm (scaling and limit value monitoring). The following settings are possible:
 - CHANNEL = 1: level
 - CHANNEL = 2: distance
 - CHANNEL = 3: temperature
5. In the parameter group XD_SCALE select the desired engineering unit and the block input range (measuring range) for the process variable in question (see the example below).

 **Caution!**

Make sure that the selected unit is suitable for the measurement variable of the selected process variable. Otherwise the parameter BLOCK_ERROR will display the error message "Block Configuration Error" and the block operating mode cannot be set to AUTO.

6. In the L_TYPE parameter, select the mode of linearization for the input variable (Direct, Indirect, Indirect Sq Root). For details →  91, "Appendix".

 **Caution!**

Note that with the type of linearization "Direct" the configuration of the parameter group OUT_SCALE must agree with the configuration of the parameter group XD_SCALE. Otherwise the block operating mode cannot be set to AUTO. Such incorrect configuration is indicated in the parameter BLOCK_ERROR by the "Block Configuration Error" message.

Example:

- The measuring range of the sensor is 0 to 10 m (33 ft).
- The output range to the automation system should be 0 to 10 m (33 ft), too.

The following settings are to be made:

- Analog Input Block 1, Parameter CHANNEL -> "1" (measured level)
 - Parameter L_TYPE -> DIRECT
 - Parameter group XD_SCALE
 - XD_SCALE 0% -> 0
 - XD_SCALE 100% -> 10
 - XD_SCALE_UNIT -> m
 - Parameter group OUT_SCALE
 - OUT_SCALE 0% -> 0
 - OUT_SCALE 100% -> 10
 - OUT_SCALE_UNIT -> m
7. If required, use the following parameters to define the limit values for alarm and warning messages:
 - HI_HI_LIM -> Limit value for the upper alarm
 - HI_LIM -> Limit value for the upper warning
 - LO_LIM -> Limit value for the lower warning
 - LO_LO_LIM -> Limit value for the lower alarm

The limit values entered must be within the value range specified in the parameter group OUT_SCALE.

8. In addition to the limit values you must also specify the action taken if a limit value is exceeded using the alarm priorities (parameters HI_HI_PRI, HI_PRI, LO_PRI, LO_LO_PRI). Reporting to the the fieldbus host system only takes place if the alarm priority is higher than 2. For details refer → 91, "Appendix".

6.5.5 Connection of the function blocks

1. A concluding overall system configuration is essential so that the operating mode of the Analog Input Block can be set to AUTO and so that the field device is integrated into the system application. To do this, a configuration software (e.g. you host system software) is used to connect the function blocks - normally graphically - to the desired control strategy and then the sequence of the individual process control functions is specified.

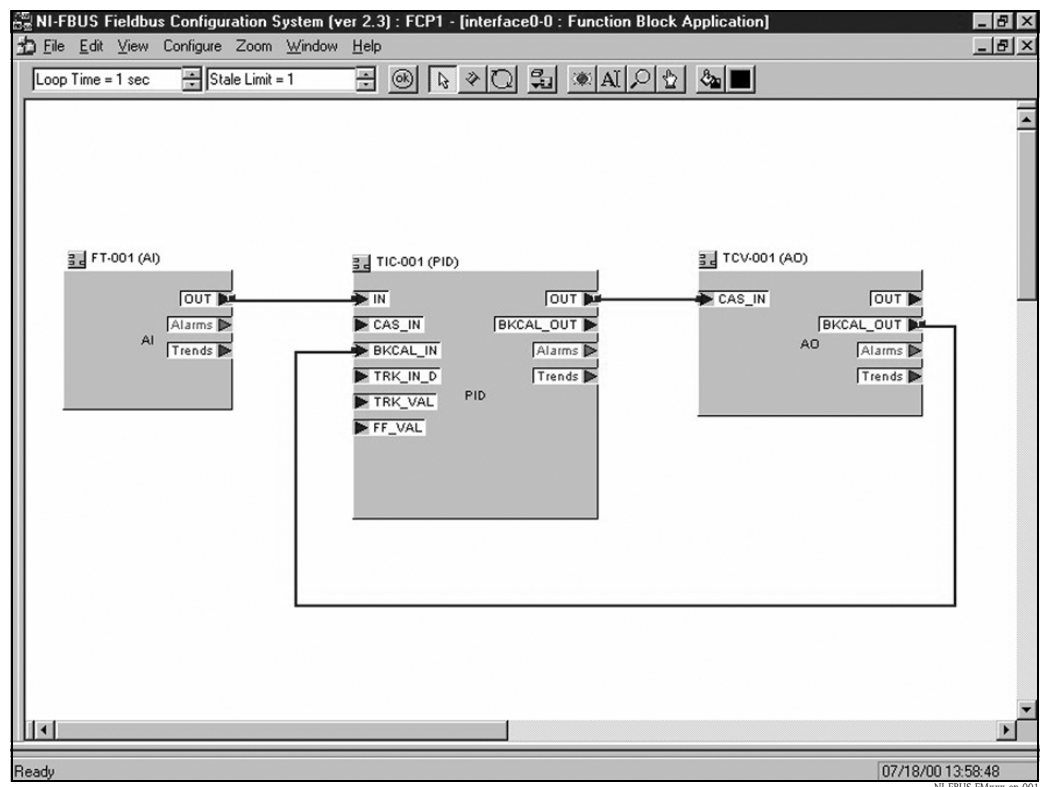

Example: Connection of the function blocks with the NI-FBUS Configurator

2. Download the configuration data into the field devices by the download function of the FOUNDATION Fieldbus configuration tool.
3. Set the operating mode of the AI Block to AUTO (parameter group MODE_BLK, parameter TARGET). However, this is only possible under the following conditions:
 - The function blocks are correctly connected with each other.
 - The parametrization of the AI Block is correct (→ Kap. 6.5.4, steps 5 and 6).
 - The Resource Block is in operating mode AUTO.

7 Troubleshooting

7.1 System error messages

7.1.1 Current error

Errors which the Prosonic M detects during commissioning or operation are displayed in the following way:

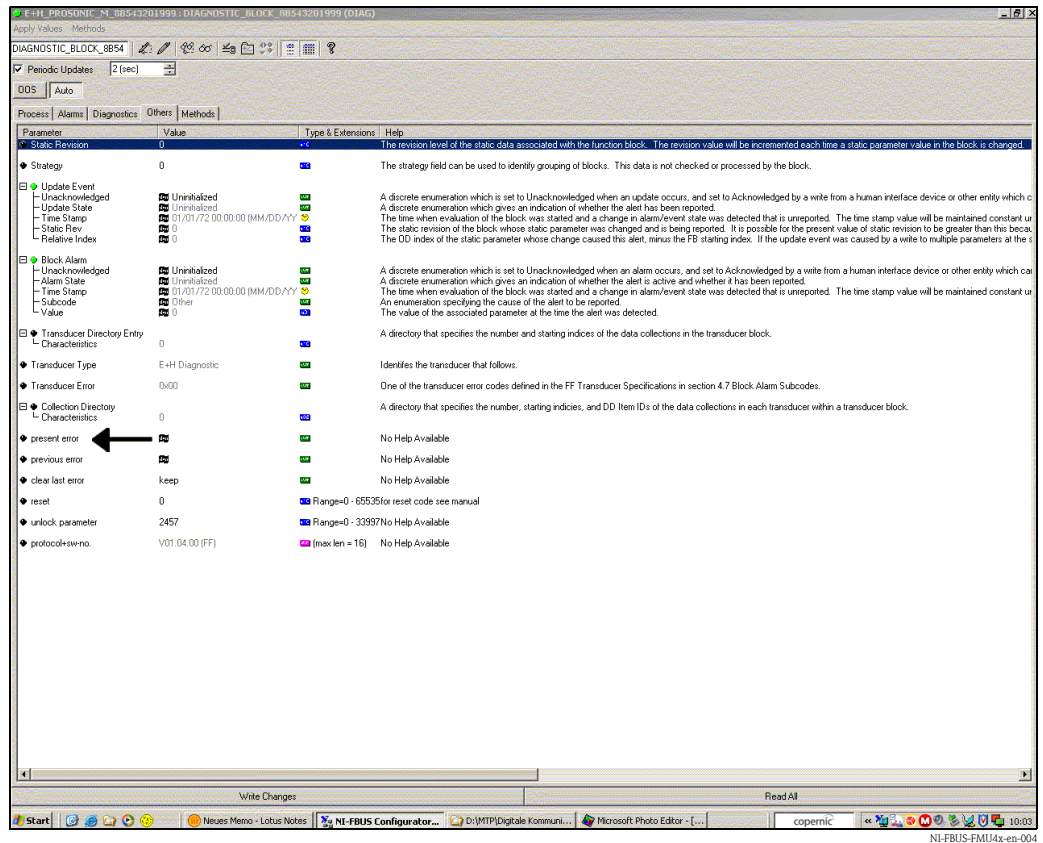

- **VU331:**
error symbol in the **"measured value" (000)** function
- **VU331 or Endress+Hauser operating program:**
in the **"diagnostics" (0A)** function group in the **"present error" (0A0)** function
Only the highest priority error is displayed; in the case of multiple errors, you can scroll between the different error messages by pressing **+** or **-**.
- **FOUNDATION Fieldbus:**
 - by the status of the main value in the cyclic data telegram
 - Diagnostic Block, parameter PARACTUALERROR (present error)



7.1.2 Last error

The last error is displayed in the **"diagnostics" (0A)** function group in the **"previous error" (0A1)** function. This display can be deleted in the **"clear last error" (0A2)** function. (FOUNDATION Fieldbus; Diagnostic Block; parameters PARLASTERROR and PARCLEARLASTERROR.

7.1.3 Types of error

Type of error	Symbol	Meaning
Alarm (A)	 continuous	The output signal assumes a value which can be set using the "output on alarm" (010) function: <ul style="list-style-type: none"> ■ MAX: 110% ■ MIN: -10% ■ Hold: last value is on hold ■ User-specific value
Warning (W)	 flashing	The device continues measurement. An error message is displayed.
Alarm/Warning (E)	You can define whether the error should behave as an alarm or as a warning.	

7.1.4 Error codes

Code	Error description	Action
A102 A110 A152 A160	checksum error	Reset; If alarm still present after reset, replace electronics
W103	initialising	If the message does not disappear after several seconds, replace the electronics
A106	downloading	Wait; Message disappears after load sequence
A111 A113 A114 A115 A121 A125 A155 A164 A171	electronics defect	Reset; Check system for EMC, improve as necessary If alarm still present after reset, replace electronics
A116	download error	Check connection; Restart download
W153	initialising	Wait a few seconds; if error is still displayed, switch the power off and on again
A231	sensor defect	Check connection, if necessary replace HF module or electronics
A281	interruption temperature sensor	Exchange sensor
A502	Sensor type not detected	Exchange sensor and/or electronics
A512	recording of mapping	Alarm disappears after a few seconds
A521	new sensor type detected	Reset
W601	linearisation curve not monotone	Correct table (enter monotonously increasing table)
W611	less than 2 linearisation points	Enter additional value pairs
W621	simulation on	Switch simulation mode off [" output" (06) function group, " simulation" (065) function]]
E641	no usable echo	Check basic calibration
E651	level in safety distance - risk of overflow	Error disappears when the level leaves the safety distance. Possibly reset the lock. [" safety settings" (01) function group, " ackn. alarm" (017) function]]
A661	Sensor overtemperature	
A671	Linearisation incomplete	Activate linearisation table
W681	current out of range	Carry out basic calibration; check linearisation

Code	Error description	Action
W691	Filling noise detected, level ramp is active	

7.1.5 Influence of the error codes on the output signal



The following table describes the influence of the error codes on the status of the cyclic output values as well as on the parameters BLOCK_ERR and XD_ERROR in the Sensor Block. The output values are linked to the following measuring values:

- Primary Value (PV): level/volume
- Secondary Value (SV): distance between sensor membrane and surface of the material measured
- Third Value (TV): sensor temperature

Code	PV Status SV Status	PV Substatus SV Substatus	TV Status	TV Substatus	BLOCK_ER	XD_ERROR
A102	BAD	Device Failure	BAD	Device Failure	Memory Failure/ Device needs maintenance now	Electronic Failure
W103	Uncertain	Non specific	GOOD	Non specific	Other	Unspecified Err
A106	BAD	Device Failure	BAD	Device Failure	Other	Unspecified Err
A110	BAD	Device Failure	BAD	Device Failure	Memory Failure/ Device needs maintenance	Electronic Failure
A111	BAD	Device Failure	BAD	Device Failure	Memory Failure/ Device needs maintenance now	Electronic Failure
A113	BAD	Device Failure	BAD	Device Failure	Memory Failure/ Device needs maintenance now	Electronic Failure
A114	BAD	Device Failure	BAD	Device Failure	Memory Failure/ Device needs maintenance now	Electronic Failure
A115	BAD	Device Failure	BAD	Device Failure	Device needs maintenance now	Unspecified Err
A116	BAD	Device Failure	BAD	Device Failure	Device needs maintenance now	Unspecified Err
A121	BAD	Device Failure	BAD	Device Failure	Memory Failure/ Device needs maintenance now	Electronic Failure
A125	BAD	Device Failure	BAD	Device Failure	Memory Failure/ Device needs maintenance now	Electronic Failure
W153	Uncertain	Non specific	GOOD	Non specific	Power up	No Error
A155	BAD	Device Failure	BAD	Device Failure	Device needs maintenance now	Electronic Failure
A160	BAD	Device Failure	BAD	Device Failure	Memory Failure/ Device needs maintenance now	Electronic Failure
A164	BAD	Device Failure	BAD	Device Failure	Memory Failure/ Device needs maintenance now	Electronic Failure
A171	BAD	Device Failure	BAD	Device Failure	Memory Failure/ Device needs maintenance now	Electronic Failure
A231	BAD	Device Failure	BAD	Device Failure	Device needs maintenance now	Unspecified Err
E281 (Warning)	Uncertain	Device Failure	BAD	Device Failure	Device needs maintenance now	Electronic Failure
E281 (Alarm)	BAD	Device Failure	BAD	Device Failure	Device needs maintenance now	Unspecified Err
A502	BAD	Device Failure	BAD	Device Failure	Device needs maintenance now	Unspecified Err
A512	Uncertain	Non specific	GOOD	Non specific	Other	Unspecified Err
A521	BAD	Device Failure	BAD	Device Failure	Device needs maintenance now	Unspecified Err
W601	Uncertain	configuration error	GOOD	Non specific	Other	Configuration Error
W611	Uncertain	configuration error	GOOD	Non specific	Other	Configuration Error
W621	Uncertain	Non specific	GOOD	Non specific	simulation active	No Error

Code	PV Status SV Status	PV Substatus SV Substatus	TV Status	TV Substatus	BLOCK_ER	XD_ERROR
E641 (Alarm)	BAD	Device Failure	GOOD	Non specific	Device needs maintenance now	Unspecified Err
E641 (Warning)	Uncertain	Non specific	GOOD	Non specific	Device needs maintenance now	Unspecified Err
E651 (Alarm)	BAD	Device Failure	GOOD	Non specific	Other	Unspecified Err
E651 (Warning)	Uncertain	Non specific	GOOD	Non specific	Other	Unspecified Err
A661 (Alarm)	BAD	Device Failure	GOOD	Non specific	Device needs maintenance now	Unspecified Err
E661 (Warning)	Uncertain	Non specific	GOOD	Non specific	Device needs maintenance soon	Unspecified Err
A671	BAD	Device Failure	GOOD	Non specific	Configuration Error	No Error
W691	Uncertain	Non specific	GOOD	Non specific	Other	Unspecified Err

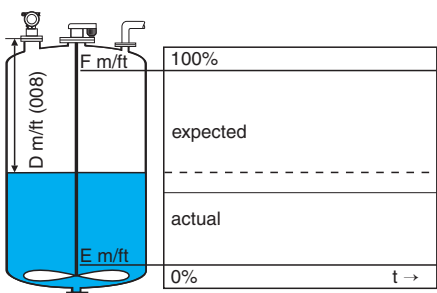
7.2 Application errors

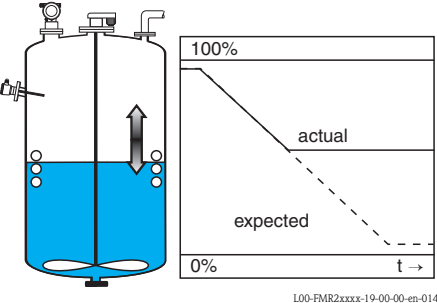
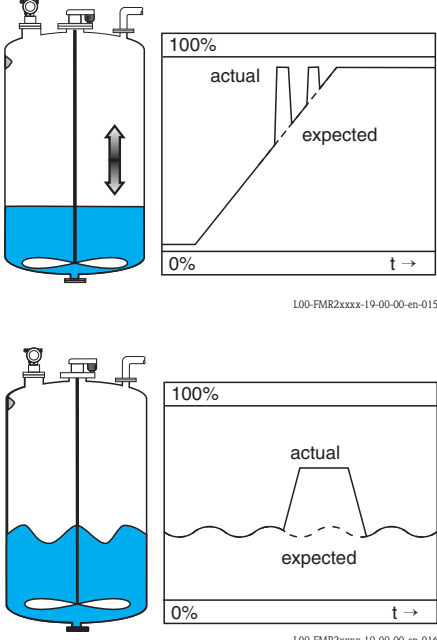
Error	Example	Elimination
<p>Measured value (00) is incorrect but measured distance (008) is correct</p>	 <p>L00-FMR2xxxx-19-00-00-en-019</p>	<ol style="list-style-type: none"> 1. Check empty calibration (005) and full calibration (006). (FF: Sensor Block, PAREMPTYCALIBRATION, PARFULLCALIBRATION) 2. Check linearisation <ul style="list-style-type: none"> - level/ullage (040) (FF: Sensor Block, PARLEVELULLAGEMODE) - max. scale(046) (FF: Sensor Block, PARMAXVOLUME) - diameter vessel (047) (FF: Sensor Block, PARCYLINDERVESSEL) - linearisation table
<p>Measured value (000) and measured distance (008) are incorrect</p>	 <p>L00-FMR2xxxx-19-00-00-en-014</p>	<ol style="list-style-type: none"> 1. For measurements in bypass or stilling well: Select the according option in the "tank shape" (002) function (FF: Sensor Block, PARTANKSHAPE) 2. Carry out interference echo suppression
<p>No change in measured value on filling/emptying</p>	 <p>L00-FMR2xxxx-19-00-00-en-014</p>	<ol style="list-style-type: none"> 1. Carry out interference echo suppression. 2. Clean sensor if necessary 3. If necessary, select better installation position 4. If necessary due to wide interference echoes, set function "detection window" (0A7) to "off" (FF: Sensor Block, PARDETECTIONWINDOW)
<p>With an uneven surface (e.g. filling, emptying, running agitator) the measured value may jump sporadically to higher levels</p>	 <p>L00-FMR2xxxx-19-00-00-en-015</p> <p>L00-FMR2xxxx-19-00-00-en-016</p>	<ol style="list-style-type: none"> 1. Carry out interference echo suppression 2. Set the process cond. (004) to "calm surface" or "add. agitator" FF: Sensor Block, PARPROCESSCONDITION) 3. Increase output damping (058). (FF: Sensor Block, PAROUTPUTDAMPING) 4. If necessary, select a different installation position and/or a larger sensor

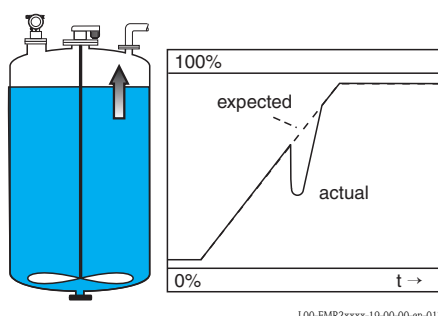
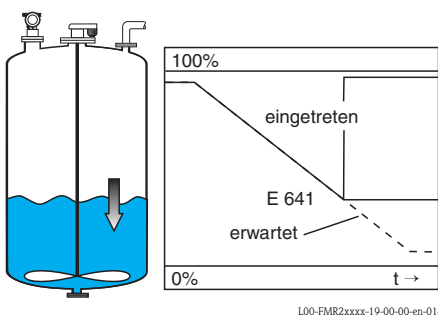
Error	Example	Elimination
<p>On filling/emptying the measured value drops</p>	 <p>The diagram shows a tank with a sensor at the bottom. An upward arrow indicates filling. The graph plots measured value (0% to 100%) against time (t). A solid line labeled 'actual' shows a sharp dip during the filling process, while a dashed line labeled 'expected' shows a smooth, linear increase.</p> <p style="text-align: right; font-size: small;">L00-FMR2xxxx-19-00-00-en-017</p>	<ol style="list-style-type: none"> 1. Check tank shape (002), e.g. "dome ceiling" or "horizontal cyl." (FF: Sensor Block, PARTANKSHAPE) 2. If possible, do not select a central installation position 3. Possible user stilling well/echo guide pipe
<p>E 641 (echo loss)</p>	 <p>The diagram shows a tank with a sensor at the bottom. A downward arrow indicates emptying. The graph plots measured value (0% to 100%) against time (t). A solid line labeled 'eingetreten' (entered) shows a sharp drop to zero. A dashed line labeled 'erwartet' (expected) shows a smooth, linear decrease. The error code 'E 641' is indicated between the two lines.</p> <p style="text-align: right; font-size: small;">L00-FMR2xxxx-19-00-00-en-018</p>	<ol style="list-style-type: none"> 1. Check application parameters (002), (003) and (004) (FF: Sensor Block, PARTANKSHAPE, PARMEDIUMCONDITION, PARPROCESSCONDITION) 2. If necessary, select a different installation position and/or a larger sensor 3. Align the sensor parallel to the product surface (particularly for bulk solids applications)

8 Maintenance and repairs

8.1 Exterior cleaning

When cleaning the exterior, always use cleaning agents that do not attack the surface of the housing and the seals.

8.2 Repairs

The Endress+Hauser repair concept assumes that the measuring devices have a modular design and that customers are able to undertake repairs themselves → [67](#), "Spare Parts". For more information on service and spare parts, contact the Service Department at Endress+Hauser.

8.3 Repairs to Ex-approved devices

When carrying out repairs to Ex-approved devices, please note the following:

- Repairs to Ex-approved devices may only be carried out by trained personnel or by the Endress+Hauser Service.
- Comply with the prevailing standards, national Ex-area regulations, safety instructions (XA) and certificates.
- Only use original spare parts from Endress+Hauser.
- When ordering a spare part, please note the device designation on the nameplate. Only replace parts with identical parts.
- Carry out repairs according to the instructions. On completion of repairs, carry out the specified routine test on the device.
- Only Endress+Hauser Service may convert a certified device into a different certified variant.
- Document all repair work and conversions.

8.4 Replacement

After a complete instrument or electronic module has been replaced, the parameters can be downloaded into the instrument again via the communication interface. Prerequisite to this is that the data were uploaded to the PC beforehand using FieldCare. Measurement can continue without having to carry out a new setup. Only a linearisation and a tank map (interference echo suppression) have to be recorded again.

8.5 Spare Parts

An overview of the spare parts for your device is available in the internet at www.endress.com. To obtain information on the spare parts, proceed as follows:

1. Go to "www.endress.com" and select your country.
2. Click "Instruments".

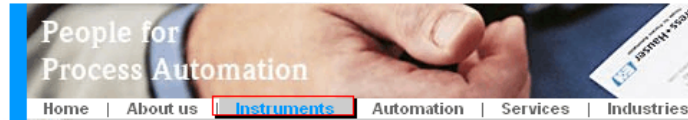

3. Enter the product name into the "product name" field.

Endress+Hauser product search

Via product name

Enter the product name

4. Select the device.
5. Click the "Accessories/Spare parts" tab.

General information	Technical information	Documents/Software	Service	Accessories/Spare parts
---------------------	-----------------------	--------------------	---------	-------------------------

- ▶ Accessories
- ▼ All Spare parts
 - ▶ Housing/housing accessories
 - ▶ Sealing
 - ▶ Cover
 - ▶ Terminal module
 - ▶ HF module
 - ▶ Electronic
 - ▶ Power supply
 - ▶ Antenna module



Advice

Here you'll find a list of all available accessories and spare parts. To only view accessories and spare parts specific to your product(s), please contact us and ask about our Life Cycle Management Service.

◀ | 1 / 2 | ▶ | 🔍

6. Select the required spare parts (You may also use the overview drawing on the right side of the screen.)

When ordering spare parts, always quote the serial number indicated on the nameplate. As far as necessary, the spare parts also include replacement instructions.

8.6 Return

Returning devices

The measuring device must be returned if repairs or a factory calibration are required, or if the wrong measuring device has been ordered or delivered. According to legal regulations, Endress+Hauser, as an ISO-certified company, is required to follow certain procedures when handling returned products that are in contact with medium.

To ensure swift, safe and professional device returns, please read the return procedures and conditions on the Endress+Hauser website at www.services.endress.com/return-material

8.7 Disposal

In case of disposal please separate the different components according to their material consistence.

8.8 Software history

Software version / date	Changes to software	Changes to documentation
V 01.02.00 / 01.2002 V 01.02.02 / 03.2003	Original software Compatible with: <ul style="list-style-type: none"> ■ ToF Tool ■ Commuwin II (version 2.05.03 and higher) ■ HART Communicator DXR 275 (from OS 4.6) with Rev. 1, DD 1 	
V 01.02.04 / 02.2004	<ul style="list-style-type: none"> ■ FMU42 added ■ compatible with HART Communicator DXR375 	FMU42 added
V 01.04.00 / 07.2006	<ul style="list-style-type: none"> ■ "detection window" function added can be operated via: <ul style="list-style-type: none"> ■ ToF Tool from version 4.50 ■ HART Communicator DXR375 with Rev. 1, DD1 FOUNDATION Fieldbus Transducer Block divided into: <ul style="list-style-type: none"> ■ Sensor Block ■ Diagnostic Block ■ Display Block Execution time of the function blocks reduced: <ul style="list-style-type: none"> ■ AI: 30 ms ■ PID: 80 ms ■ AR: 50 ms ■ IS: 30 ms ■ SC: 40 ms ■ IT: 60 ms 	"detection window" added Version: 07.06 Description of FOUNDATION Fieldbus interface completely revised. Version: 11.06

8.9 Contact addresses of Endress+Hauser

Contact addresses can be found on our homepage: www.endress.com/worldwide. If you have any questions, please contact your Endress+Hauser sales representative.

9 Accessories

9.1 Weather protection cover

A Weather protection cover made of stainless steel is recommended for outdoor mounting (order code: 543199-0001). The shipment includes the protective cover and tension clamp.

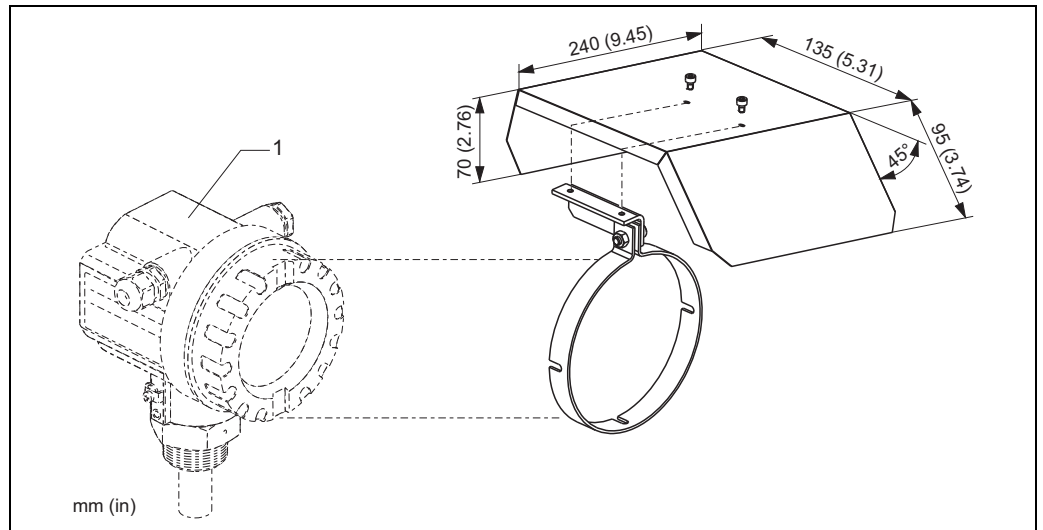

1 F12 / T12 housing

9.2 Installation bracket for FMU40, FMU41

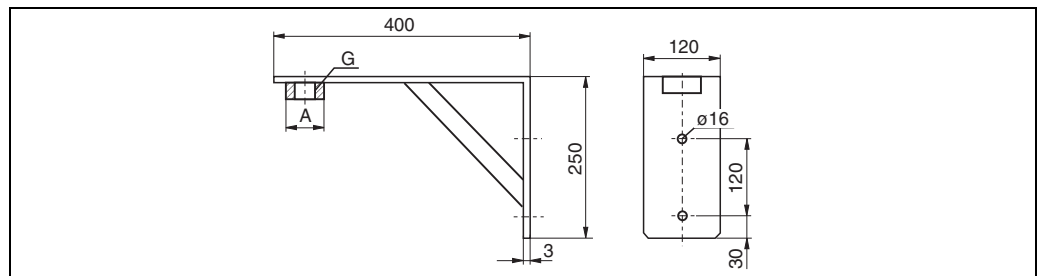

Dimensions in mm

- for FMU 40, G1½: Order No. 942669-0000
- for FMU 41, G2: Order No. 942669-0001

suited for NPT 1½" and 2" as well

9.3 Screw in flange

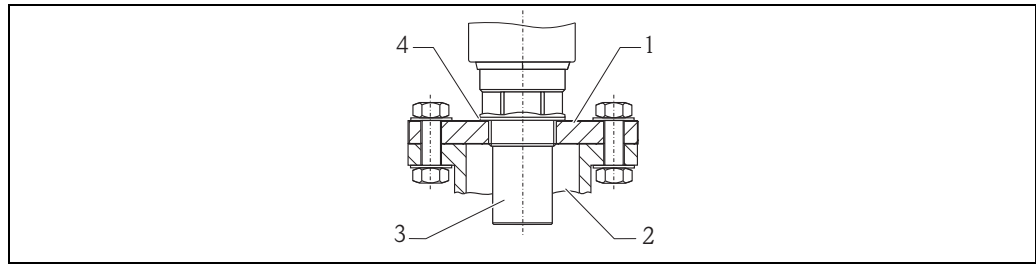

100-FMU30xxx-00-00-00-xx-001

- 1 Screw in flange
- 2 Nozzle
- 3 Sensor
- 4 Sealing ring EPDM (supplied)

Screw in flange FAX50

015 Material:	
BR1	DN50 PN10/16 A, steel flange EN1092-1
BS1	DN80 PN10/16 A, steel flange EN1092-1
BT1	DN100 PN10/16 A, steel flange EN1092-1
JF1	2" 150lbs FF, steel flange ANSI B16.5
JG1	3" 150lbs FF, steel flange ANSI B16.5
JH1	4" 150lbs FF, steel flange ANSI B16.5
JK2	8" 150lbs FF, PP max 3bar abs/44psia flange ANSI B16.5
XIF	UNI flange 2"/DN50/50, PVDF max 4bar abs/58psia, suitable for 2" 150lbs/DN50 PN16/10K 50
XIG	UNI flange 2"/DN50/50, PP max 4bar abs/58psia, suitable for 2" 150lbs/DN50 PN16/10K 50
XIJ	UNI flange 2"/DN50/50, 316L max 4bar abs/58psia, suitable for 2" 150lbs/DN50 PN16/10K 50
XJF	UNI flange 3"/DN80/80, PVDF max 4bar abs/58psia, suitable for 3" 150lbs/DN80 PN16/10K 80
XJG	UNI flange 3"/DN80/80, PP max 4bar abs/58psia, suitable for 3" 150lbs/DN80 PN16/10K 80
XJJ	UNI flange 3"/DN80/80, 316L max 4bar abs/58psia, suitable for 3" 150lbs/DN80 PN16/10K 80
XKF	UNI flange 4"/DN100/100, PVDF max 4bar abs/58psia, suitable for 4" 150lbs/DN100 PN16/10K 100
XKG	UNI flange 4"/DN100/100, PP max 4bar abs/58psia, suitable for 4" 150lbs/DN100 PN16/10K 100
XKJ	UNI flange 4"/DN100/100, 316L max 4bar abs/58psia, suitable for 4" 150lbs/DN100 PN16/10K 100
XLF	UNI flange 6"/DN150/150, PVDF max 4bar abs/58psia, suitable for 6" 150lbs/DN150 PN16/10K 150
XLG	UNI flange 6"/DN150/150, PP max 4bar abs/58psia, suitable for 6" 150lbs/DN150 PN16/10K 150
XLJ	UNI flange 6"/DN150/150, 316L max 4bar abs/58psia, suitable for 6" 150lbs/DN150 PN16/10K 150
XMG	UNI flange DN200/200, PP max 4bar abs/58psia, suitable for DN200 PN16/10K 200
XNG	UNI flange DN250/250, PP max 4bar abs/58psia, suitable for DN250 PN16/10K 250
YYY	Special version

020 Sensor Connection:	
A	Thread ISO228 G3/4
B	Thread ISO228 G1
C	Thread ISO228 G1-1/2
D	Thread ISO228 G2
E	Thread ANSI NPT3/4
F	Thread ANSI NPT1
G	Thread ANSI NPT1-1/2
H	Thread ANSI NPT2
Y	Special version

The filled in options result in the complete order code.

	015	020
FAX50 -		

9.4 Cantilever

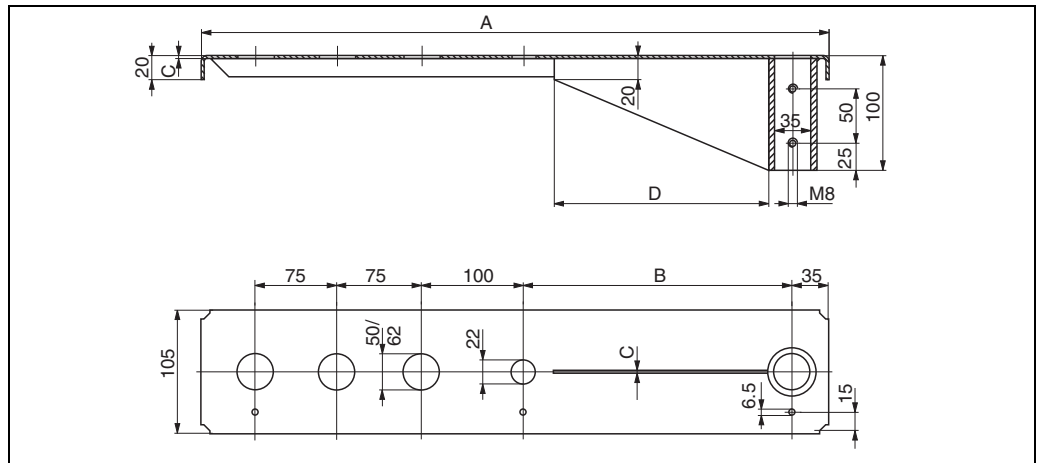

L00-FMU4xxxx-06-00-00-yy-005

Dimensions in mm

A	B	C	D	for Sensor	Material	Order Code
585 (23)	250 (9.84)	2 (0.08)	200 (7.87)	1½"	316Ti (1.4571)	52014132
					galv. steel	52014131
				2"	316Ti (1.4571)	52014136
					galv. steel	52014135
1085 (42.7)	750 (29.5)	3 (0.12)	300 (11.8)	1½"	316Ti (1.4571)	52014134
					galv. steel	52014133
				2"	316Ti (1.4571)	52014138
					galv. steel	52014137

mm (in)

- The 50 mm (2.17 in) or 62 mm (2.44 in) orifices serve for the mounting of the FMU40 or FMU41 sensor, respectively.
- The 22 mm (0.87 in) orifice may be used for an additional sensor.

For the mounting of the cantilever can be used:

- mounting frame → 72
- wall bracket → 72

9.5 Mounting Frame

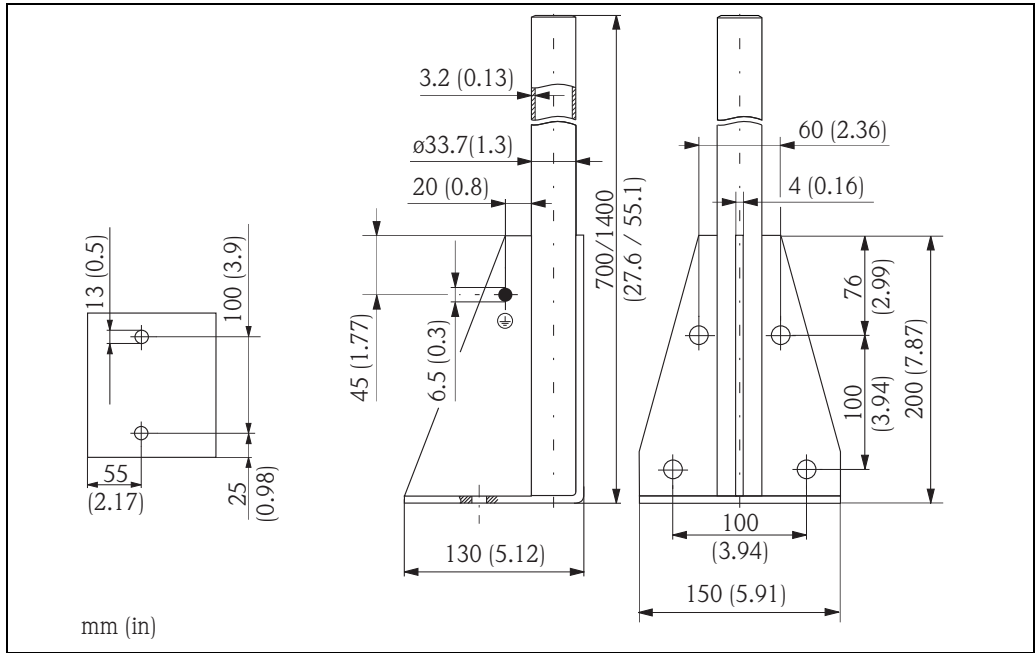

100-FMU4x-00-00-00-xx-005

Height	Material	Order Code
700 (27.6)	galv. steel	919791-0000
700 (27.6)	316Ti (1.4571)	919791-0001
1400 (55.1)	galv. steel	919791-0002
1400 (55.1)	316Ti (1.4571)	919791-0003

mm (in)

9.6 Wall Bracket

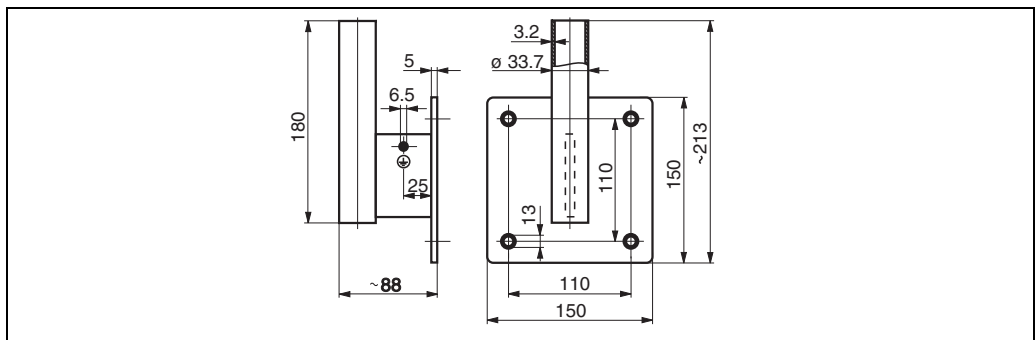

100-FMU4x-00-00-00-yy-006

Dimensions in mm

Material	Order Code
galv. steel	919792-0000
316Ti (1.4571)	919792-0001

9.7 Mounting bracket for FMU 42/43/44

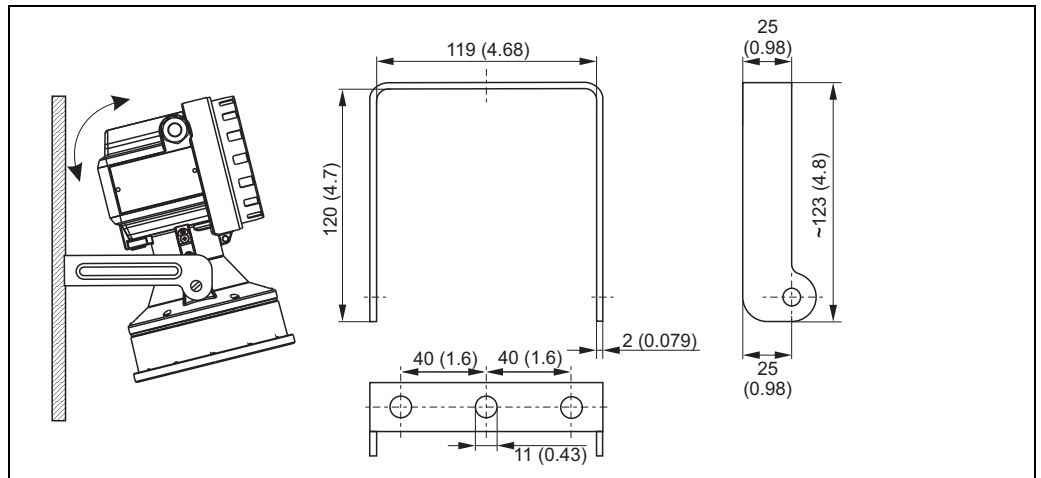

Dimensions in mm (in)

100-FMU4x-00-00-00-xx-003

9.8 Commubox FXA195 HART

For intrinsically safe communication with FieldCare via the USB interface.
For details refer to TI00404F/00/EN.

9.9 Commubox FXA291

The Commubox FXA291 connects Endress+Hauser field instruments with CDI interface (= Endress+Hauser Common Data Interface) to the USB interface of a personal computer or a notebook. For details refer to TI00405C/07/EN.



Note!

For the instrument you need the "ToF Adapter FXA291" as an additional accessory.

9.10 ToF Adapter FXA291

The ToF Adapter FXA291 connects the Commubox FXA291 via the USB interface of a personal computer or a notebook for the instrument. For details refer to KA00271F/00/A2.

9.11 Remote display FHX40

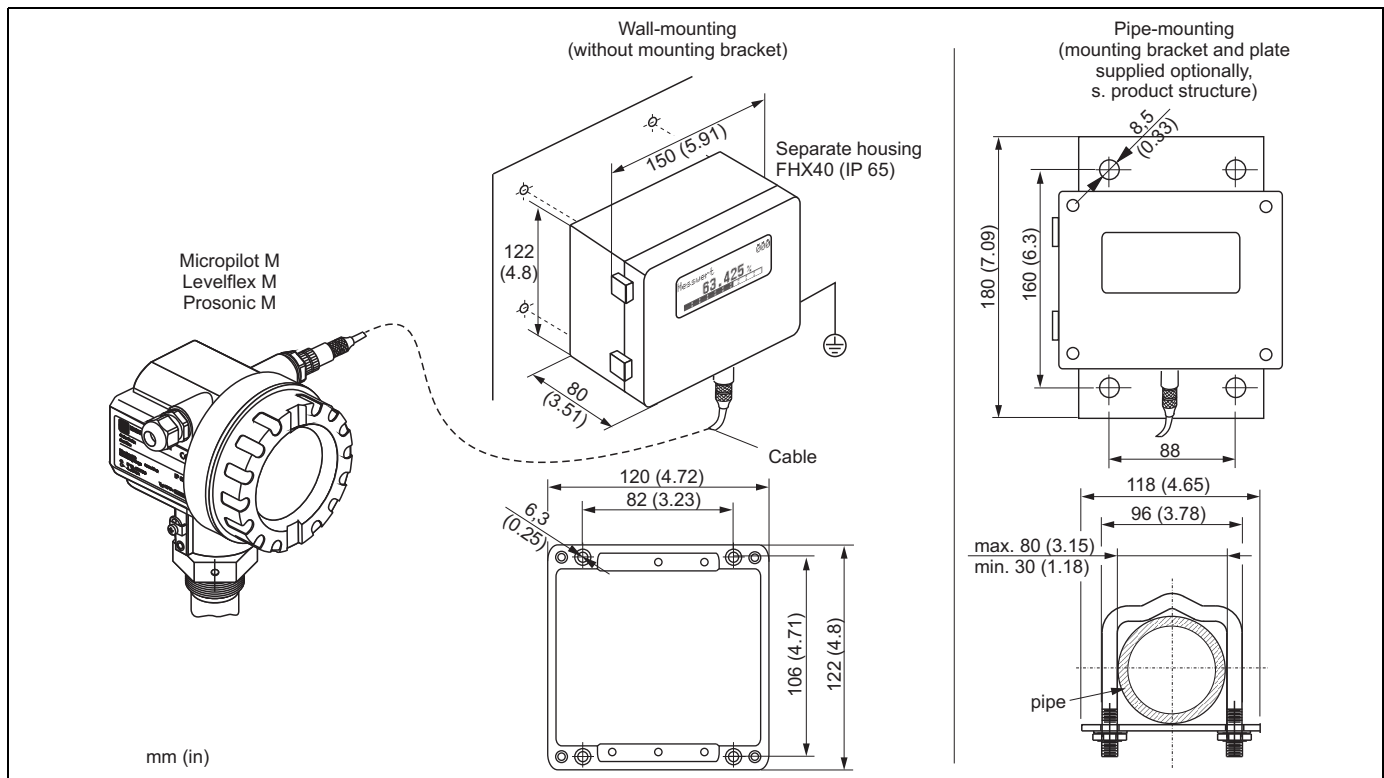

100-FHXxxxxx-00-00-06-est-003

9.11.1 Technical data (cable and housing) and product structure:

Max. cable length	20 m (65 ft)
Temperature range	-40 °C to +60 °C (-40 °F to 140 °F)
Degree of protection	IP65/67 (housing); IP68 (cable) acc. to IEC 60529
Dimensions mm/in	(HxWxD) 122x150x80 / 4.8x5.9x3.2

010	Approval:		
	A	Non-hazardous area	
	2	ATEX II 2G Ex ia IIC T6	
	3	ATEX II 2D Ex ia IIIC T80°C	
	G	IECEX Zone1 Ex ia IIC T6/T5	
	S	FM IS Cl. I Div.1 Gr. A-D, zone 0	
	U	CSA IS Cl. I Div.1 Gr. A-D, zone 0	
	N	CSA General Purpose	
	K	TIIIS Ex ia IIC T6	
	C	NEPSI Ex ia IIC T6/T5	
	Y	Special version, TSP-Nr. to be spec.	
020	Cable:		
	1	20m / 65ft: for HART	
	5	20m / 65ft: for PROFIBUS PA/FOUNDATION Fieldbus	
	9	Special version, TSP-Nr. to be spec.	
030	Additional option:		
	A	Basic version	
	B	Mounting bracket, pipe 1" / 2"	
	Y	Special version, TSP-Nr. to be spec.	
995	Marking:		
	1	Tagging (TAG)	
FHX40 -		Complete product designation	

For connection of the remote display FHX40 use the cable which fits the communication version of the respective instrument.

10 Technical Data

10.1 Technical data at a glance

10.1.1 Input

Measured variable The distance D between the sensor membrane and the product surface is measured.
 Using the linearisation function, the device uses D to calculate:

- level L in any units
- volume V in any units
- flow Q across measuring weirs or open channels in any units

Maximum range/blocking distance

Sensor	Maximum range in liquids ¹	Maximum range in solids ¹	Blocking distance
FMU40	5 m (16 ft)	2 m (6.6 ft)	0.25 m (0.8 ft)
FMU41	8 m (26 ft)	3.5 m (11 ft)	0.35 m (1.1 ft)
FMU42	10 m (33 ft)	5 m (16 ft)	0.4 m (1.3 ft)
FMU43	15 m (49 ft)	7 m (23 ft)	0.6 m (2.0 ft)
FMU44	20 m (66 ft)	10 m (33 ft)	0.5 m (1.6 ft)

¹The actual range is dependent on the measuring conditions. Refer to Technical Information TI00365F/00/EN for an estimation.

10.1.2 Output

Output signal FOUNDATION Fieldbus

Signal Coding Manchester Bus Powered (MBP); Manchester II

Data transmission rate 31.25 KBit/s, voltage mode

Signal on alarm

- Error symbol, error code and plain text description on the on-site display
- Status byte of the digital signal input

10.1.3 Data of the FOUNDATION Fieldbus interface

Basic Data

Device Type	1011 (hex)
Device Revision	04 (hex)
DD Revision	01 (hex)
CFF Revision	01 (hex)
ITK Version	4.61
ITK-Certification Driver-No.	IT035900
Link Master (LAS) capable	yes
Link Master / Basic Device selectable	yes; Default: Basic Device
Number VCRs	24
Number of Link-Objects in VFD	24

Virtual communication references (VCRs)

Permanent Entries	1
Client VCRs	0
Server VCRs	24
Source VCRs	23
Sink VCRs	0
Subscriber VCRs	23
Publisher VCRs	23

Link Settings

Slot time	4
Min. Inter PDU delay	4
Max. response delay	10

Transducer Blocks

Block	Content	Output values
Sensor Block	contains all parameters related to the measurement	<ul style="list-style-type: none"> ■ level or volume¹⁾ (channel 1) ■ distance (channel 2) ■ sensor temperature (channel 3)
Diagnsotic Block	contains diagnostic information	no output values
Display Block	contains parameters to configure the local display	no output values

1) je nach Konfiguration des Sensor-Blocks

Function Blocks

Block	Content	Execution time	Functionality
Resource Block	The Resource Block contains all the data that uniquely identifies the field device. It is an electronic version of a nameplate of the device.		enhanced
Analog Input Block 1	The AI block takes the manufacturer's input data, selected by channel number, and makes it available to other function blocks at its output.	30 ms	standard
Analog Input Block 2	The AI block takes the manufacturer's input data, selected by channel number, and makes it available to other function blocks at its output.	30 ms	standard
PID Block	The PID block serves as proportional-integral-derivative controller and is used almost universally to do closed-loop-control in the field including cascade and feedforward.	80 ms	standard
Arithmetic Block	This block is designed to permit simple use of popular measurement math functions. The user does not have to know how to write equations. The math algorithm is selected by name, chosen by the user for the function to be done.	50 ms	standard
Input Selector Block	The input selector block provides selection of up to four inputs and generates an output based on the configured action. This block normally receives its inputs from AI blocks. The block performs maximum, minimum, middle, average and 'first good' signal selection.	30 ms	standard
Signal Characterizer Block	The signal characterizer block has two sections, each with an output that is a non-linear function of the respective input. The non-linear function is determined by a single look-up table with 21 arbitrary x-y pairs.	40 ms	standard

Block	Content	Execution time	Functionality
Integrator Block	The Integrator Function Block integrates a variable as a function of the time or accumulates the counts from a Pulse Input block. The block may be used as a totalizer that counts up until reset or as a batch totalizer that has a setpoint, where the integrated or accumulated value is compared to pre-trip and trip settings, generating discrete signals when these settings are reached.	60 ms	standard

10.1.4 Power supply

Terminals	Cable cross-section: 0.5 to 2.5 mm (20 to 14 AWG)										
Cable entry	<ul style="list-style-type: none"> ■ Cable gland M20x1.5 (recommended cable diameter 6 to 10 mm (0.24 to 0.39 in)) ■ Cable entry G$\frac{1}{2}$ or $\frac{1}{2}$ NPT ■ 7/8" FOUNDATION Fieldbus plug 										
Supply voltage	9 V to 32 V There may be additional restrictions for devices with an explosion protection certificate. Refer to the notes in the appropriate safety instructions (XA).										
Lift-off voltage	9 V										
Basic current	15 mA										
In-rush current	≤ 15 mA										
Error current	0 mA										
FISCO	<table border="1"> <tbody> <tr> <td>U_i</td> <td>17,5 V</td> </tr> <tr> <td>I_i</td> <td>500 mA; with surge arrester 273 mA</td> </tr> <tr> <td>P_i</td> <td>5,5 W; with surge arrester 1, 2 W</td> </tr> <tr> <td>C_i</td> <td>5 mF</td> </tr> <tr> <td>L_i</td> <td>0,01 mH</td> </tr> </tbody> </table>	U_i	17,5 V	I_i	500 mA; with surge arrester 273 mA	P_i	5,5 W; with surge arrester 1, 2 W	C_i	5 mF	L_i	0,01 mH
U_i	17,5 V										
I_i	500 mA; with surge arrester 273 mA										
P_i	5,5 W; with surge arrester 1, 2 W										
C_i	5 mF										
L_i	0,01 mH										
FNICO compliant	yes										
Polarity sensitive	no										

10.1.5 Performance characteristics

Reaction time The reaction time depends on the parameter settings. The minimum values are:

- FMU40/41/42/43: min. 2 s
- FMU44: min. 3 s

Reference operating conditions

- Temperature = +20 °C (+68 °F)
- Pressure = 1013 mbar abs. (15 psi abs.)
- Humidity = 50 %
- Ideal reflective surface (e.g. calm, smooth fluid surface)
- No interference reflections within signal beam
- Set application parameters:
 - Tank shape = flat ceiling
 - Medium property = liquid
 - process conditions = calm surface

Measured value resolution

Sensor	Measured value resolution
FMU40	1 mm (0.04 in)
FMU41	1 mm (0.04 in)
FMU42	2 mm (0.08 in)
FMU43	2 mm (0.08 in)
FMU44	2 mm (0.08 in)

Measuring error

Typical specifications for reference operating conditions (include linearity, repeatability, and hysteresis):

Sensor	Measuring error
FMU40	± 2 mm (0.08 in) or 0.2% of set measuring distance (empty calibration) ¹
FMU41	± 2 mm (0.08 in) or 0,2% of set measuring distance (empty calibration) ¹
FMU42	± 4 mm (0.16 in) or 0,2% of set measuring distance (empty calibration) ¹
FMU43	± 4 mm (0.16 in) or 0,2% of set measuring distance (empty calibration) ¹
FMU44	± 4 mm (0.16 in) or 0,2% of set measuring distance (empty calibration) ¹

¹whichever is greater

Influence of the vapor pressure

The vapor pressure at 20 °C (68 °F) gives a hint on the accuracy of the ultrasonic level measurement. If the vapor pressure at 20 °C (68 °F) is below 50 mbar (1 psi), ultrasonic level measurement is possible with a very high accuracy. This is valid for water, aqueous solutions, water-solid-solutions, dilute acids (hydrochloric acid, sulfuric acid, ...), dilute bases (caustic soda, ...), oils, greases, slurries, pastes, ...

High vapor pressures or outgassing media (ethanol, acetone, ammonia, ...) can influence the accuracy. If conditions like these are present, please contact the Endress+Hauser support.

10.1.6 Ambient conditions

Ambient temperature	-40 °C to +80 °C (-40 °F to +176 °F) The functionality of the LC display becomes restricted at $T_u < -20$ °C ($T_u < -4$ °F) and $T_u > +60$ °C ($T_u > +140$ °F). If the device is operated outdoors in strong sunlight, you should use a protective cover.
Storage temperature	-40 °C to +80 °C (-40 °F to +176 °F)
Climate class	DIN EN 60068-2-38 (Test Z/AD) DIN/IEC 68 T2-30Db
Ingress protection	<ul style="list-style-type: none"> ■ With closed housing, tested according to <ul style="list-style-type: none"> – IP 68, NEMA 6P (24h at 1.83 m (6 ft) under water surface) – IP 66, NEMA 4x ■ With open housing: IP 20, NEMA 1 (also ingress protection of the display)
Vibration resistance	DIN EN 60068-2-64 / IEC 68-2-64: 20...2000 Hz, 1 (m/s ²) ² /Hz; 3 x 100 min
Electromagnetic compatibility (EMC)	■ Electromagnetic compatibility according to all relevant requirements of the EN 61326- series and NAMUR recommendation EMC (NE21). For details see declaration of conformity.

10.1.7 Process conditions

Process temperature	-40 °C to +80 °C (-40 °F to +176 °F) A temperature sensor is integrated in the sensor for correction of the temperature-dependent time-of-flight.
Process pressure	<ul style="list-style-type: none"> ■ FMU40, FMU41: 0.7 bar to 3bar abs. (10.15 psi to 43.5 psi abs.) ■ FMU42, FMU43, FMU44: 0.7 bar to 2.5bar abs. (10.15 psi to 36.25 psi abs.)

11 Appendix

11.1 Operating menu

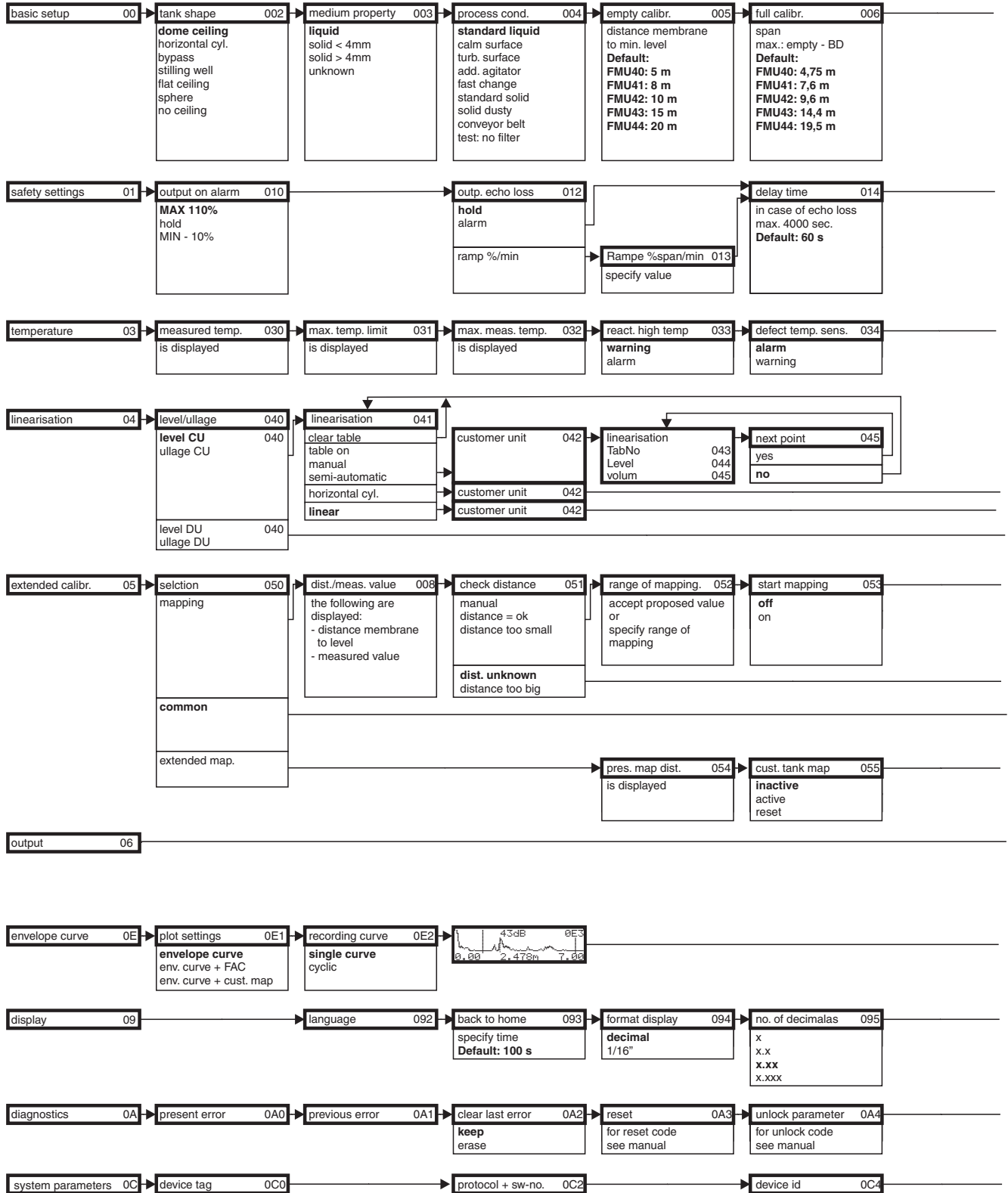

Note! The Default values of the parameters are typed in bold face.

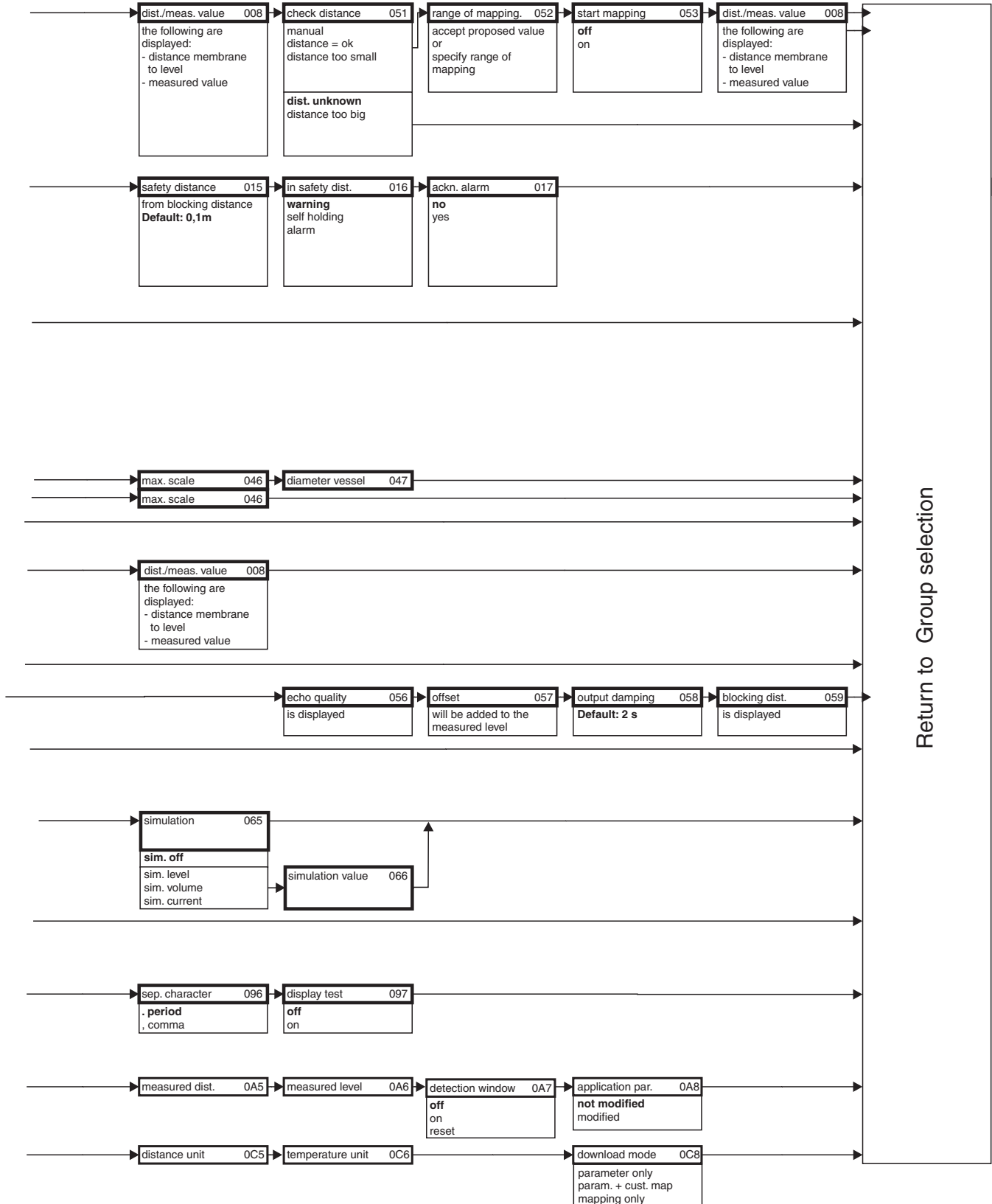

11.2 Block model of the Prosonic M

The Prosonic M contains the following blocks:

- **Resource Block (RB2)**
 - s. Operating Instructions BA00013S: "FOUNDATION Fieldbus - Overview"
- **Sensor Block (TBUL)**
 - contains the parameters relevant to the measurement
- **Diagnostic Block (DIAG)**
 - contains the diagnostic parameters of the Prosonic M
- **Display Block (DISP)**
 - contains the configuration parameters for the display module VU331
- **Analog-Input-Block 1 bzw. 2 (AI)**
 - scale the signal of the Transducer Block and transmit them to the PLCS
- **PID Block (PID)**
 - s. Operating Instructions BA00013S: "FOUNDATION Fieldbus - Overview"
- **Arithmetic Block (AR)**
 - s. Operating Instructions BA00013S: "FOUNDATION Fieldbus - Overview"
- **Input Selector Block (IS)**
 - s. Operating Instructions BA00013S: "FOUNDATION Fieldbus - Overview"
- **Signal Characterizer Block (SC)**
 - s. Operating Instructions BA00013S: "FOUNDATION Fieldbus - Overview"
- **Integrator Block (IT)**
 - s. Operating Instructions BA00013S: "FOUNDATION Fieldbus - Overview"

11.2.1 Default Block configuration

The input and output variables of the blocks can be interconnected by a network configuration tool (e.g. NI-Fieldbus configurator). The figure below shows, how these connections are set by default.

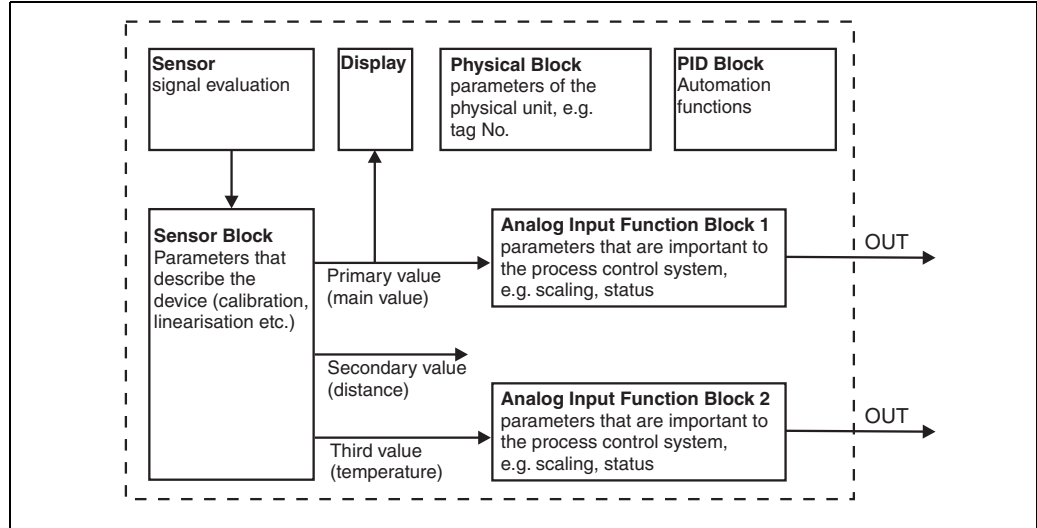

11.3 Resource block

The resource block contains the parameters used to describe physical resources of the device. It has no linkable inputs or outputs.

11.3.1 Operation

The resource block is opened by a click on the resource line.

If the NI-FBUS Configurator is being used, a series of file tabs appears on the screen. The files can be opened to view and/or edit the parameters in the following table. A short description of the parameter function appears on the side of the screen. A change in the parameter is stored by pressing the WRITE CHANGES button when the block is out of service. Press the READ ALL button to check the values stored in the device.

11.3.2 Parameters

Parameter	Description
TAG_DESC	User description of the intended application of the block.
MODE_BLK	<p>Lists the actual, target, permitted and normal operating modes of the block.</p> <ul style="list-style-type: none"> – Target: changes the operating mode of the block – Actual: indicates the current operating mode of the block – Permitted: states which operating modes are allowed – Normal: indicates the normal operating mode of the block <p>The possible operating modes of the resources block are:</p> <ul style="list-style-type: none"> – AUTO: the block is operating as normal – OOS: the block is out of service <p>If the resource block is out of service, then all blocks within the device (resource) are forced into the same status.</p>
RS_STATE	<p>Indicates the state of the resource block application state machine</p> <ul style="list-style-type: none"> – On-line: block in AUTO mode – Standby: block in OOS mode
WRITE_LOCK	<p>Indicates the status of DIP-switch WP</p> <ul style="list-style-type: none"> – LOCKED: device data can be modified – NOT LOCKED: device data can be modified
RESTART	<p>Allows a manual restart:</p> <ul style="list-style-type: none"> – UNINITIALISED: no status – RUN: normal operational status – RESOURCE: resets the resource block parameters – DEFAULTS: Resets all FOUNDATION Fieldbus parameters within the device, but not the manufacturer specific parameters. – PROCESSOR: make a warm start of the processor
BLOCK_ERROR	<p>Shows error status of software and hardware components</p> <ul style="list-style-type: none"> – Out-of-Service: the block is in OOS mode – Simulation active: shows the setting of DIP-switch SIM
BLOCK_ALM	Shows any configuration, hardware, connection and system problems in the lock. The cause of the alert is to be seen in the subcode field.

The function of the resource block parameters not described here can be taken from the FOUNDATION Fieldbus specification, see "www.fieldbus.org".

11.4 Sensor Block

The Sensor block contains the parameters required to calibrate the device. These parameters can also be addressed by using the VU331 display module. The calibration of the device is described in → Chap. 6, "Commissioning".

11.4.1 Operation

Parameter changes from the tool are made off-line while the device is operating. The changes are downloaded by first setting MODE_BLK = OOS then pressing the WRITE CHANGES button. Press the READ ALL button to check the values stored in the device. In order to resume operation, change MODE_BLK to AUTO³⁾.

11.4.2 Output values

Parameter	Description
PRIMARY_VALUE	Main value (level, volume or flow)
SECONDARY_VALUE	Measured distance
THIRD_VALUE	Measured temperature

11.4.3 Configuration parameters

The Sensor block also contains the configuration parameters, which are used to commission and calibrate the instrument. They are identical to the functions of the operating menu, except for the service parameters which are not accessible on the bus. Thus, the calibration procedure via the display module (→ 40 "Commissioning") is equally valid for a calibration via a network configuration tool.

A complete list of the configuration parameters can be found in the "Description of Instrument Functions", BA00240F/00/EN.

3) If MODE_BLK refuses to be changed to AUTO, an error is present. Control all parameters, perform the required changes and try again to change MODE_BLK to AUTO.

11.4.4 Methods

The FOUNDATION Fieldbus specification provides for the use of so-called methods to simplify the operation of the device. A method is an interactive sequence of steps that must be followed in order to obtain a particular function from the device.

The Prosonic M has got the following methods:

- Basic setup
- Safety settings
- Acknowledge alarm
- temperature
- Linearisation
- Extended calibration
- Output
- System parameters
- Lock TB Manufacturer parameters

Most of these methods are identical to the respective function group in the operating menu. A detailed description of them can be found in the "Description of Instrument functions", BA00240F.

11.4.5 Parameter list of the Prosonic M Sensor Block

Parameter	Position Indicator	rel. Index	Variable Name	Size [bytes]	Type	Access	Storage Class	Changeable in Mode
measured value	000	18	PARMEASUREDVALUE	4	FloatingPoint	RO	dynamic	Auto, OOS
tank shape	002	19	PARTANKSHAPE	1	Unsigned8	RW	static	OOS
medium property	003	20	PARMEDIUMCONDITION	1	Unsigned8	RW	static	OOS
process cond.	004	21	PARPROCESSCONDITION	1	Unsigned8	RW	static	OOS
empty calibr.	005	22	PAREMPTYCALIBRATION	4	FloatingPoint	RW	static	OOS
full calibr.	006	23	PARFULLCALIBRATION	4	FloatingPoint	RW	static	OOS
echo quality	056	24	PARCHOQUALITY	1	Unsigned8	RO	dynamic	Auto, OOS
check distance	051	25	PARCHECKDISTANCE	1	Unsigned8	RW	dynamic	OOS
range of mapping	052	26	PARSUPPRESSIONDISTANCE	4	FloatingPoint	RW	dynamic	OOS
start mapping	053	27	PARSTARTMAPPINGRECORD	1	Unsigned8	RW	dynamic	OOS
pres. map dist.	054	28	PARPRESMAPRANGE	4	FloatingPoint	RO	dynamic	Auto, OOS
cust. tank map	055	29	PARCUSTTANKMAP	1	Unsigned8	RW	dynamic	OOS
offset	057	30	PAROFFSETOFMEASUREDDISTANCE	4	FloatingPoint	RW	static	OOS
output damping	058	31	PAROUTPUTDAMPING	4	FloatingPoint	RW	static	Auto, OOS
blocking dist.	059	32	PARBLOCKINGDISTANCE	4	FloatingPoint	RW	static	OOS
output on alarm	010	33	PAROUTPUTONALARM	1	Unsigned8	RW	static	OOS
outp. echo loss	012	34	PARREACTIONLOSTECHO	1	Unsigned8	RW	static	OOS
ramp %span/min	013	35	PARRAMPINPERCENTPERMIN	4	FloatingPoint	RW	static	OOS
delay time	014	36	PARDELAYTIMEONLOSTECHO	2	Unsigned16	RW	static	OOS
safety distance	015	37	PARLEVELWITHINSAFETYDISTANCE	4	FloatingPoint	RW	static	OOS
in safety dist.	016	38	PARINSAFETYDISTANCE	1	Unsigned8	RW	static	OOS
ackn. alarm	017	39	PARACKNOWLEDGEALARM	1	Unsigned8	RW	dynamic	Auto, OOS
measured temp.	030	40	PARMEASUREDTEMPERATURE	4	FloatingPoint	RO	dynamic	Auto, OOS
max. temp. limit	031	41	PARMAXTEMPLIMIT	4	FloatingPoint	RO	dynamic	Auto, OOS
max. meas. temp	032	42	PARMAXMEASUREDTEMPERATURE	4	FloatingPoint	RO	non-vol.	Auto, OOS
react. high temp	033	43	PARONHIGHTEMPERATURE	1	Unsigned8	RW	static	OOS
defect temp sens	034	44	PARDEFECTTEMPERATURESENSOR	1	Unsigned8	RW	static	OOS

Parameter	Position Indicator	rel. Index	Variable Name	Size [bytes]	Type	Access	Storage Class	Changeable in Mode
level/ullage	040	45	PARLEVELULLAGEMODE	1	Unsigned8	RW	static	OOS
linearisation	041	46	PARLINEARISATION	1	Unsigned8	RW	static	OOS
customer unit	042	47	PARCUSTOMERUNIT	2	Unsigned16	RW	static	OOS
table no.	043	48	PARTABLENUMBER	1	Unsigned8	RW	non-vol.	Auto, OOS
input level	044	49	PARINPUTLEVELHALFAUTOMATIC	4	FloatingPoint	RO	dynamic	Auto, OOS
input level	044	50	PARINPUTLEVELMANUAL	4	FloatingPoint	RW	dynamic	OOS
input volume	045	51	PARINPUTVOLUME	4	FloatingPoint	RW	dynamic	OOS
max. scale	046	52	PARMAXVOLUME	4	FloatingPoint	RW	static	OOS
diameter vessel	047	53	PARCYLINDERVESSEL	4	FloatingPoint	RW	static	OOS
simulation	065	54	PARSIMULATION	1	Unsigned8	RW	dynamic	OOS
simulation value	066	55	PARSIMULATIONVALUELEVEL	4	FloatingPoint	RW	dynamic	Auto, OOS
simulation value	066	56	PARSIMULATIONVALUEVOLUME	4	FloatingPoint	RW	dynamic	Auto, OOS
unlock parameter	0A4	57	PAROPERATIONCODE	2	Unsigned16	RW	non-vol.	OOS
measured dist.	0A5	58	PARMEASUREDDISTANCE	4	FloatingPoint	RO	dynamic	Auto, OOS
measured level	0A6	59	PARMEASUREDLEVEL	4	FloatingPoint	RO	dynamic	Auto, OOS
detection window	0A7	60	PARDETECTIONWINDOW	1	Unsigned8	RW	dynamic	OOS
application par.	0A8	61	PARAPPLICATIONPARAMETER	1	Unsigned8	RO	dynamic	Auto, OOS
distance unit	0C5	62	PARDISTANCEUNIT	2	Unsigned16	RW	static	OOS
temperature unit	0C6	63	PARTEMPERATUREUNIT	2	Unsigned16	RW	static	OOS
download mode	0C8	64	PARDOWNLOADMODE	1	Unsigned8	RW	static	OOS
max meas dist	0D84	65	PARABSMAXMESSDIST	4	FloatingPoint	RO	dynamic	Auto, OOS
max sample dist.	0D88	66	PAREDITRANGEMAXSAMPLEDIST	4	FloatingPoint	RO	dynamic	Auto, OOS
present error	0A0	67	PARACTUALERROR	2	Unsigned16	RO	dynamic	Auto, OOS

11.5 Diagnostic Block

11.5.1 Operation

The diagnostic block contains the error messages of the instrument. These parameters can also be addressed by using the VU331 display module.

The diagnostic block is opened by clicking on the "diagnostic" line.

Parameter changes from the tool are made off-line while the device is operating. The changes are downloaded by first setting MODE_BLK = OOS then pressing the WRITE CHANGES button. Press the READ ALL button to check the values stored in the device. In order to resume operation, change MODE_BLK to AUTO⁴).

11.5.2 Block administration parameters

Parameter	Description
MODE_BLK	See description in Resource block. The possible operating modes of the Sensor block are: – AUTO: the block is operating as normal. – OOS: the block is out of service.
TAG_DESC	User description of the intended application of the block.
BLOCK_ERROR	Shows the error status associated with the block components – Out-of-Service: the block is in OOS mode.

11.5.3 Methods

The FOUNDATION Fieldbus specification provides for the use of so-called methods to simplify the operation of the device. A method is an interactive sequence of steps that must be followed in order to obtain a particular function from the device.

The Prosonic M has got the following methods:

- Set to customer default
- Diagnostics

Most of these methods are identical to the respective function group in the operating menu. A detailed description of them can be found in the "Description of Instrument functions", BA00240F.

11.5.4 Instrument specific parameters

Parameter	Position Indicator	rel. Index	Variable Name	Size [bytes]	Type	Access	Storage Class	Changeable in Mode
present error	0A0	13	PARACTUALERROR	2	Unsigned16	RO	dynamic	Auto, OOS
previous error	0A1	14	PARLASTERROR	2	Unsigned16	RO	non-vol.	Auto, OOS
clear last error	0A2	15	PARCLEARLASTERROR	1	Unsigned8	RW	dynamic	Auto, OOS
reset	0A3	16	PARRESET	2	Unsigned16	RW	dynamic	OOS
unlock parameter	0A4	17	PAROPERATIONCODE	2	Unsigned16	RW	non-vol.	OOS
protocol+sw-no.	0C2	18	PARPROTSOFTVERSIONSTRING	16	VisibleString	RO	const	Auto, OOS

4) If MODE_BLK refuses to be changed to AUTO, an error is present. Control all parameters, perform the required changes and try again to change MODE_BLK to AUTO.

11.6 Display Block

11.6.1 Operation

The display block contains the parameters required to parametrise the display module VU331 (which is contained in the remote display and operating unit FHX40). These parameters can also be addressed by using the VU331 display module.

The display block is opened by clicking on the "display" line.

Parameter changes from the tool are made off-line while the device is operating. The changes are downloaded by first setting MODE_BLK = OOS then pressing the WRITE CHANGES button. Press the READ ALL button to check the values stored in the device. In order to resume operation, change MODE_BLK to AUTO⁵).

11.6.2 Block administration parameters

Parameter	Description
MODE_BLK	See description in Resource block. The possible operating modes of the sensor block are: – AUTO: the block is operating as normal. – OOS: the block is out of service.
TAG_DESC	User description of the intended application of the block.
BLOCK_ERROR	Shows the error status associated with the block components – Out-of-Service: the block is in OOS mode.

11.6.3 Methods

The FOUNDATION Fieldbus specification provides for the use of so-called methods to simplify the operation of the device. A method is an interactive sequence of steps that must be followed in order to obtain a particular function from the device.

The Prosonic M has got the following methods:

- Display

Most of these methods are identical to the respective function group in the operating menu. A detailed description of them can be found in the "Description of Instrument functions", BA00240F.

11.6.4 Instrument specific parameters

Parameter	Position Indicator	rel. Index	Variable Name	Size [bytes]	Type	Access	Storage Class	Changeable in Mode
language	092	13	PARLANGUAGE	1	Unsigned8	RW	non-vol.	Auto, OOS
back to home	093	14	PARBACKTOHOME	2	Integer16	RW	non-vol.	Auto, OOS
format display	094	15	PARFORMATDISPLAY_FT	1	Unsigned8	RW	non-vol.	Auto, OOS
no.of decimals	095	16	PARNOOFDECIMALS	1	Unsigned8	RW	non-vol.	Auto, OOS
sep. character	096	17	PARSEPARATIONCHARACTER	1	Unsigned8	RW	non-vol.	Auto, OOS
unlock parameter	0A4	18	PAROPERATIONCODE	2	Unsigned16	RW	non-vol.	OOS

5) If MODE_BLK refuses to be changed to AUTO, an error is present. Control all parameters, perform the required changes and try again to change MODE_BLK to AUTO.

11.7 Analog input block

The analog input block conditions the signal output by the Sensor block and outputs signal to the PCL or other function blocks.

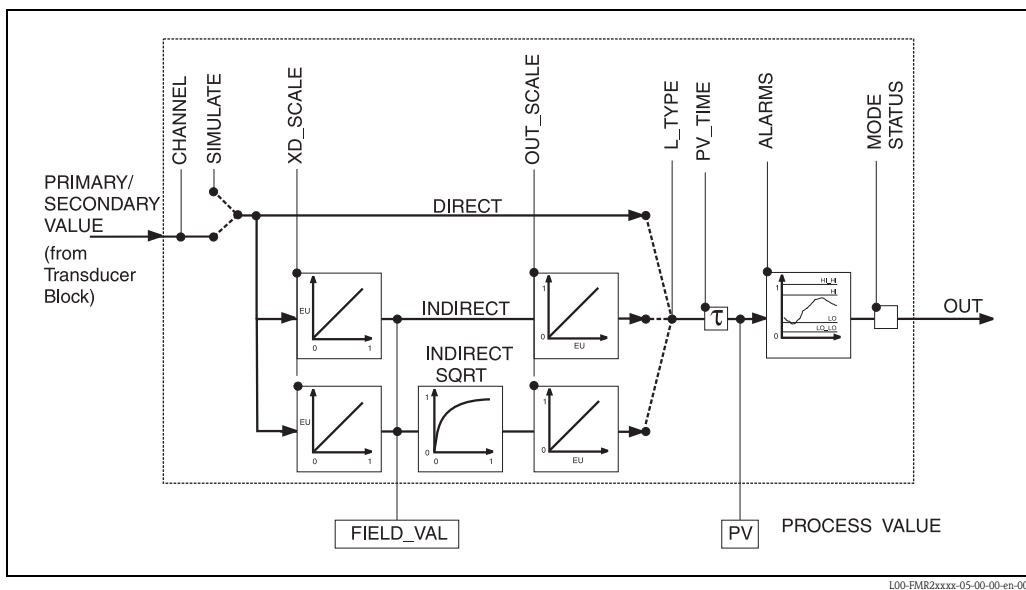

11.7.1 Operation

The resource block is opened by a click on the resource line. Parameter changes from the tool are made off-line while the device is operating. The changes are downloaded by first setting MODE_BLK = OOS then pressing the WRITE CHANGES button. Press the READ ALL button to check the values stored in the device. Normally operation is resumed as soon as MODE-BLK is set to AUTO.

11.7.2 Block administration parameters

Parameter	Description
MODE_BLK	See description in Resource block. The possible operating modes of the Sensor block are: <ul style="list-style-type: none"> - AUTO: the block is operating as normal - MAN: the block is operated with a manually entered primary value. - OOS: the block is out of service.
TAG_DESC	User description of the intended application of the block.
BLOCK_ERROR	Shows error status of software and hardware components <ul style="list-style-type: none"> - Out-of-Service: the block is in OOS mode - Simulation active: shows the setting of DIP-switch SIM. Input failure/process variable has BAD status. - configuration error

11.7.3 Output values

Parameter	Description
PV	Either the primary/secondary Sensor block value used to execute the block or a process value associated with it. Comprises value and status.
OUT	The primary value output as a result of executing the analog input block. Comprises value and status.
FIELD_VALUE	Raw value of field device in % of PV range with a status reflecting the Sensor condition before signal characterisation L_Type or filtering V_TIME. Comprises value and status.

11.7.4 Scaling parameters

Parameter	Description
CHANNEL	Selects the measured value to be input to the analogue input block <ul style="list-style-type: none"> - 0 = no channel defined - 1 = primary value: measured level/volume - 2 = secondary value: measured distance
XD_SCALE	Scales the Sensor block value in the required engineering units (EU).
OUT_SCALE	Scales the output value in the required engineering units (EU).
L_TYPE	Sets the linearization type: <ul style="list-style-type: none"> - DIRECT: the Sensor block value bypasses the scaling functions - INDIRECT: the Sensor block value is fed through the linear scaling functions - INDIRECT SORT: the Sensor block value is fed through the square root scaling functions

The relationship between the output values and scaling parameters is as follows:

$$\text{FIELD_VAL} = 100 \times \frac{\text{CHANNEL_VALUE} - \text{XD_SCALE_MIN}}{\text{XD_SCALE_MAX} - \text{XD_SCALE_MIN}}$$

The L_TYPE parameter influences the signal conversion:

- Direct:

$$\text{PV} = \text{CHANNEL_VALUE}$$

- Indirect:

$$\text{PV} = \frac{\text{FIELD_VALUE}}{100} \times (\text{OUT_SCALE_MAX} - \text{OUT_SCALE_MIN}) + \text{OUT_SCALE_MIN}$$

- Indirect square root:

$$\text{PV} = \sqrt{\frac{\text{FIELD_VALUE}}{100}} \times (\text{OUT_SCALE_MAX} - \text{OUT_SCALE_MIN}) + \text{OUT_SCALE_MIN}$$

11.7.5 Output response parameters

Parameter	Description
LOW_CUT	Not relevant to level measurement! Determines a threshold for square root linearization below which the output value is set to zero.
PV_FTIME	Sets the time constant for the output value.

11.7.6 Alarm parameters

Parameter	Description
ACK_OPTION	Sets the way in which alarms and warnings are to be acknowledged.
ALARM_HYS	Sets the hysteresis (in output engineering units) for all configured alarms. A hysteresis of e.g. 2% on a HI_HI_LIMIT of 95% would cause the alarm to activate when the level reaches 95% and to deactivate when the level drops below 93%. A hysteresis of e.g. 2% on a LO_LO_LIMIT of 5% would cause the alarm to activate when the level drops below 5% and to deactivate when the level rises to 7%.
HI_HI_PRI	The priority (1 – 15) of the HI_HI alarm
HI_HI_LIM	Sets the HI_HI alarm limit in output engineering units
HI_PRI	The priority (1 – 15) of the HI alarm
HI_LIM	Sets the HI warning limit in output engineering units
LO_PRI	The priority (1 – 15) of the LO alarm
LO_LIM	Sets the LO warning limit in output engineering units
LO_LO_PRI	The priority (1 – 15) of the LO_LO alarm
LO_LO_LIM	Sets the LO_LO alarm limit in output engineering units

11.7.7 Alarm priorities

Parameter	Description
0	Alarm is suppressed
1	Recognised by the system but not reported
2	Reported to the operator, but does not require his attention
3 - 7	Advisory alarms of increasing priority
8 - 15	Critical alarms of increasing priority

11.7.8 Alarm status

Parameter	Description
HI_HI_ALM	The status of the HI_HI alarm
HI_ALM	The status of the HI alarm
LO_ALM	The status of the LO alarm
LO_LO_ALM	The status of the LO_LO alarm

11.7.9 Simulation

The SIMULATE parameter allows the Sensor block output value to be simulated, provided simulation has also been enabled at the device DIP switch. The simulation must be enabled, a value and/or status entered and the block must be in AUTO mode. During simulation the Sensor output value is substituted by the simulated value.

A simulation is also possible by switching MODE_BLK to "MAN" and entering a value for OUT.

Parameter	Description
SIMULATE	Enables, sets and displays a simulated value, options: <ul style="list-style-type: none">- enable/disable- simulated value- output value

11.8 List of start indices

The following list indicates the start indices for all blocks and objects:

Object	Start Index
Object Dictionary	298

Object	Start Index
Resource Block	400
Analog Input 1 Function Block	500
Analog Input 2 Function Block	600
PID Function Block	700
Arithmetic Function Block	800
Input Selector Function Block	900
Signal Characterizer Function Block	1000
Integrator Function Block	1100
Sensor Block	2000
Diagnostic Block	2200
Display Block	2400

Object	Start Index
View Objects Resource Block	3000
View Objects Analog Input 1 Function Block	3010
View Objects Analog Input 2 Function Block	3020
View Objects PID Function Block	3030
View Objects Arithmetic Function Block	3040
View Objects Input Selector Function Block	3050
View Objects Signal Characterizer Function Block	3060
View Objects Integrator Function Block	3070
View Objects Sensor Block	4000
View Object Diagnostic Block	4100
View Object Display Block	4200

11.9 Measuring principle

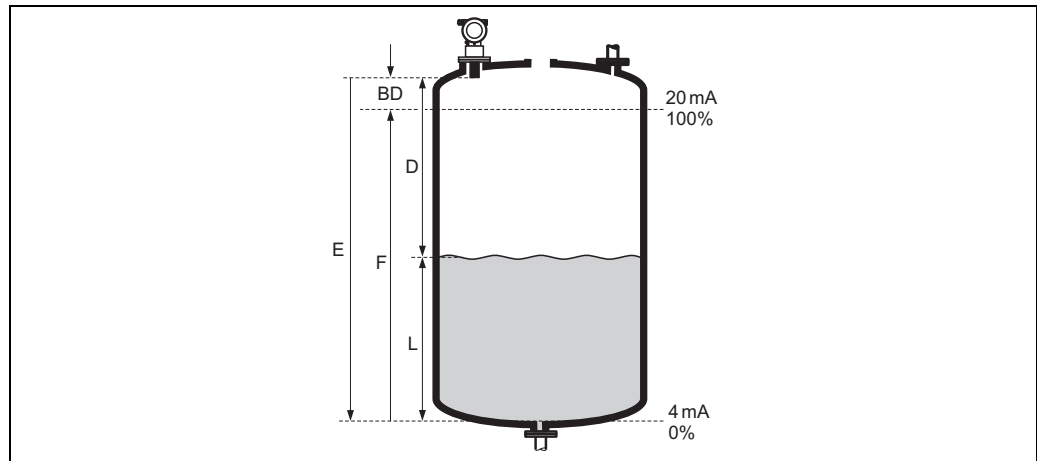

E: Empty distance; **F:** Span (full distance); **D:** Distance from sensor membrane - product surface; **L:** Level; **BD:** Blocking distance

Sensor	BD	Max. range fluids	Max. range bulk materials
FMU40	0.25 m (0.8 ft)	5 m (16 ft)	2 m (6.6 ft)
FMU41	0.35 m (1.1 ft)	8 m (26 ft)	3.5 m (11 ft)
FMU42	0.4 m (1.3 ft)	10 m (33 ft)	5 m (16 ft)
FMU43	0.6 m (2.0 ft)	15 m (49 ft)	7 m (23 ft)
FMU44	0.5 m (1.6 ft)	20 m (66 ft)	10 m (33 ft)

11.9.1 Time-of-flight method

The sensor of the Prosonic M transmits ultrasonic pulses in the direction of the product surface. There, they are reflected back and received by the sensor. The Prosonic M measures the time t between pulse transmission and reception. The instrument uses the time t (and the velocity of sound c) to calculate the distance D between the sensor membrane and the product surface:

$$D = c \cdot t/2$$

As the device knows the empty distance E from a user entry, it can calculate the level as follows:

$$L = E - D$$

An integrated temperature sensor compensates for changes in the velocity of sound caused by temperature changes.

11.9.2 Interference echo suppression

The interference echo suppression feature on the Prosonic M ensures that interference echos (e.g. from edges, welded joints and installations) are not interpreted as a level echo.

11.9.3 Calibration

Enter the empty distance E and the span F to calibrate the device.

11.9.4 Blocking distance

Span F may not extend into the blocking distance BD. Level echos within the blocking distance cannot be evaluated due to the transient characteristics of the sensor.

Index

A

alarm 61
 application errors 64

B

blocking distance 24, 49

C

cantilever 71
 CE mark 15
 cleaning 66
 Commubox 73
 connection 27

D

declaration of conformity 15
 display appearance 32
 display symbols 32

E

error codes 61
 error messages 60

F

FHX40 74
 flow measurements 22
 full calibration 49

H

hazardous area 4

I

installation bracket 69
 interference echo suppression 50

K

key assignment 33
 Khafagi-Venturi flume 22

L

level measurements 21

M

measuring principle 96
 Measuring range 24

N

nozzle 24

O

on-site display 35
 operating menu 82

P

process conditions 47

R

range 25

repairs to Ex-approved devices 66
 return 68

S

Service Interface FXA291 73
 shafts 22
 Spare Parts 67

T

turn housing 26

W

warning 61
 weather protection cover 69

www.endress.com/worldwide

Endress+Hauser 
People for Process Automation

