

# Rosemount™ 3051 Pressure Transmitter

with 4-20 mA HART® Protocol



## Safety messages

### NOTICE

Read this manual before working with the product. For personal and system safety and for optimum product performance, ensure you thoroughly understand the contents before installing, using, or maintaining this product.

### ⚠ WARNING

#### Explosions

Explosions could result in death or serious injury.

In an explosionproof/flameproof installation, do not remove the transmitter covers when power is applied to the transmitter.

Installation of device in an explosive environment must be in accordance with appropriate local, national, and international standards, codes, and practices. Review the *Product Certifications* section of the [Rosemount 3051 Quick Start Guide](#) for any restrictions associated with a safe installation.

Before connecting a handheld communicator in an explosive atmosphere, ensure that the instruments are installed in accordance with intrinsically safe or non-incendive field wiring practices.

### ⚠ WARNING

#### Process leaks

Process leaks may cause harm or result in death.

Install and tighten process connectors before applying pressure.

Do not attempt to loosen or remove flange bolts while the transmitter is in service.

### ⚠ WARNING

#### Electrical shock

Electrical shock can result in death or serious injury.

Avoid contact with the leads and terminals. High voltage that may be present on leads can cause electrical shock.

### ⚠ WARNING

#### Physical access

Unauthorized personnel may potentially cause significant damage to and/or misconfiguration of end users' equipment. This could be intentional or unintentional and needs to be protected against.

Physical security is an important part of any security program and fundamental in protecting your system. Restrict physical access by unauthorized personnel to protect end users' assets. This is true for all systems used within the facility.

### NOTICE

#### Replacement equipment

Replacement equipment or spare parts not approved by Emerson for use as spare parts could reduce the pressure retaining capabilities of the transmitter and may render the instrument dangerous.

Use only bolts supplied or sold by Emerson as spare parts.

## NOTICE

### **Improper assembly**

Improper assembly of manifolds to traditional flange can damage sensor module.

For safe assembly of manifold to traditional flange, bolts must break back plane of flange web (also called bolt hole) but must not contact sensor module housing.

Severe changes in the electrical loop may inhibit HART® Communication or the ability to reach alarm values. Therefore, Emerson absolutely cannot warrant or guarantee that the correct Failure alarm level (High or Low) can be read by the host system at the time of annunciation.

## NOTICE

### **Nuclear applications**

The products described in this document are not designed for nuclear-qualified applications. Using non-nuclear qualified products in applications that require nuclear-qualified hardware or products may cause inaccurate readings. For information on Rosemount nuclear-qualified products, contact your local Emerson Sales Representative.

## NOTICE

### **Transmitter hardware adjustments**

Set all transmitter hardware adjustments during commissioning to avoid exposing the transmitter electronics to the plant environment after installation.



# Contents

<b>Chapter 1</b>	<b>Introduction.....</b>	<b>7</b>
	1.1 Models covered.....	7
	1.2 Product recycling/disposal.....	7
<b>Chapter 2</b>	<b>Configuration.....</b>	<b>9</b>
	2.1 Overview.....	9
	2.2 Safety messages.....	9
	2.3 System readiness.....	9
	2.4 Configuration tools.....	11
	2.5 How to configure.....	14
	2.6 Application specific configuration.....	21
	2.7 Detailed transmitter setup.....	28
	2.8 Configure via Bluetooth® wireless technology.....	31
	2.9 Configuring transmitter diagnostics.....	32
	2.10 Performing transmitter tests.....	38
	2.11 Configuring Burst mode.....	39
	2.12 Establishing multidrop communication.....	40
<b>Chapter 3</b>	<b>Hardware installation.....</b>	<b>43</b>
	3.1 Overview.....	43
	3.2 Safety messages.....	43
	3.3 Considerations.....	43
	3.4 Installation procedures.....	45
<b>Chapter 4</b>	<b>Electrical installation.....</b>	<b>65</b>
	4.1 Overview.....	65
	4.2 Safety messages.....	65
	4.3 Install LCD display.....	65
	4.4 Configuring transmitter security.....	67
	4.5 Move Alarm switch.....	68
	4.6 Electrical considerations.....	69
<b>Chapter 5</b>	<b>Operation and maintenance.....</b>	<b>75</b>
	5.1 Overview.....	75
	5.2 Safety messages.....	75
	5.3 Recommended calibration tasks.....	75
	5.4 Calibration overview.....	76
	5.5 Trimming the pressure signal.....	79
	5.6 Trimming the analog output.....	81
<b>Chapter 6</b>	<b>Troubleshooting.....</b>	<b>85</b>
	6.1 Overview.....	85
	6.2 Safety messages.....	85
	6.3 Troubleshooting for 4-20 mA output.....	85
	6.4 Diagnostic messages.....	87

	6.5 Disassembling the transmitter.....	93
	6.6 Reassemble the transmitter.....	95
	6.7 Service support.....	97
<b>Chapter 7</b>	<b>Safety Instrumented Systems (SIS) requirements.....</b>	<b>99</b>
	7.1 Identify Rosemount 3051 safety certification.....	99
	7.2 Installation in Safety Instrumented Systems (SIS) applications.....	99
	7.3 Configuring in Safety Instrumented Systems (SIS) applications.....	100
	7.4 Safety Instrumented Systems (SIS) operation and maintenance.....	101
	7.5 Inspection.....	103
<b>Appendix A</b>	<b>Reference data.....</b>	<b>105</b>
	A.1 Ordering information, specifications, and drawings.....	105
	A.2 Product certifications.....	105
<b>Appendix B</b>	<b>Device Driver (DD) menu trees.....</b>	<b>107</b>
<b>Appendix C</b>	<b>Quick Service buttons.....</b>	<b>117</b>
<b>Appendix D</b>	<b>Local Operator Interface (LOI).....</b>	<b>119</b>
	D.1 Enter numbers in the Local Operator Interface (LOI).....	119
	D.2 Enter text in the Local Operator Interface (LOI).....	120

# 1 Introduction

## 1.1 Models covered

The following Rosemount 3051 Transmitters are covered by this manual:

- Rosemount 3051C Coplanar™ Pressure Transmitter
  - Measures differential and gauge pressure up to 2000 psi (137.9 bar).
  - Measures absolute pressure up to 4000 psia (275.8 bar).
- Rosemount 3051T In-Line Pressure Transmitter
  - Measures absolute pressure up to 20000 psi (1378.95 bar).
- Rosemount 3051L Liquid Level Transmitter
  - Measures level and specific gravity up to 300 psi (20.7 bar).
- Rosemount 3051CF Series Flow Meter
  - Measures flow in line sizes from ½ in. (15 mm) to 96 in. (2400 mm).

---

### Note

For transmitter with FOUNDATION™ Fieldbus, see the [Rosemount 3051 Pressure Transmitter with FOUNDATION™ Fieldbus Protocol Manual](#).

For transmitter with PROFIBUS® PA, see the [Rosemount 3051 Pressure Transmitter with PROFIBUS™ PA Protocol Manual](#).

---

## 1.2 Product recycling/disposal

Consider recycling equipment. Dispose of packaging in accordance with local and national legislation/regulations.





## 2 Configuration

### 2.1 Overview

This section contains information on commissioning and tasks that should be performed on the bench prior to installation, as well as tasks performed after installation.

This section also provides instructions on configuring using any communication device, including:

- Field Communicator, such as AMS Trex
- HART® host, such as AMS Device Manager
- AMS Device Configurator Bluetooth® app
- Physical buttons, such as the Quick Service buttons or local operator interface (LOI)

### 2.2 Safety messages

Procedures and instructions in this section may require special precautions to ensure the safety of the personnel performing the operations. Refer to [Safety messages](#).

### 2.3 System readiness

If using HART-based control or asset management systems, confirm the HART capability of such systems prior to commissioning and installation. Not all systems can communicate with HART Revision 7 devices.

## 2.3.1 Confirming correct device driver

- Verify that the latest device driver (DD/DTM™) is loaded on your systems to ensure proper communications.
- Download the latest DD at [Emerson.com](http://Emerson.com) or [FieldCommGroup.org](http://FieldCommGroup.org)
- In the **Browse by Member** drop-down menu, select the Rosemount business unit of Emerson.
- Select the desired product.
- Use the device revision numbers to find the correct DD.

**Table 2-1: Rosemount 3051 device revisions and files**

Release date	Device identification			Device driver identification		Review instructions	Review functionality
	NAMUR software revision <sup>(1)</sup>	HART® hardware revision <sup>(1)</sup>	HART software revision <sup>(2)</sup>	HART universal revision	Device revision <sup>(3)</sup>	Manual document number	Change description
March 2023	2.0.xx	2.0.xx	01	7	11	00809-0100-4007	<sup>(4)</sup>
April 2012	1.0xx	1.0xx	01	7	10	00809-0100-4007	<sup>(5)</sup>
January 1998	N/A	N/A	178	5	3	00809-0100-4001	N/A

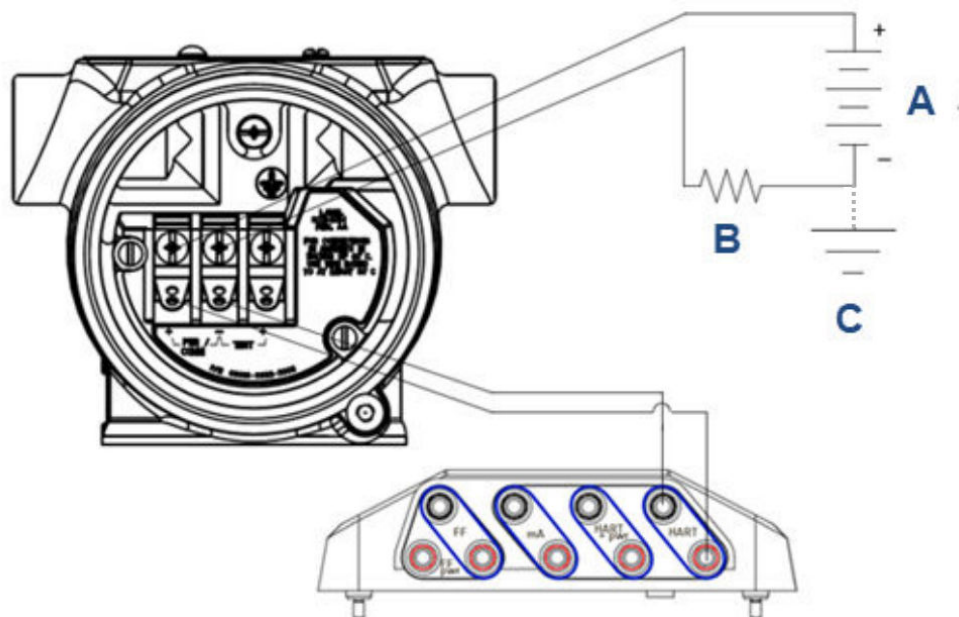
- (1) The NAMUR revision is located on the hardware tag of the device. Differences in level 3 changes, signified above by xx, represent minor product changes as defined per NE53. Compatibility and functionality are preserved, and you can use the products interchangeably.
- (2) You can read the HART software revision with a HART capable configuration tool. The value shown is the minimum revision that could correspond to NAMUR revisions.
- (3) Device driver file names use device and DD Revision, such as 10\_01. The HART protocol is designed to enable legacy device driver revisions to continue to communicate with new HART devices. To access new functionality, you must download the new device driver. Emerson recommends downloading new device driver files to ensure full functionality.
- (4) Valid for Manual revision BD or later. Changes include:
- Bluetooth® connectivity
  - Application-specific configuration
  - Plugged impulse line diagnostics
  - Enhanced safety
  - Quick Service buttons
  - Graphical display
- (5) Valid up to Manual Revision BC. Changes include:
- HART Revision 5 and 7 selectable, power diagnostics
  - Safety certified, local operator interface (LOI)
  - Process alerts
  - Scaled variable
  - Configurable alarms
  - Expanded engineering units

## 2.4 Configuration tools

You can configure the transmitter either before or after installation. To ensure that all transmitter components are in working order prior to installation, configure the transmitter on the bench using the applicable communication device and power supply.

See [Figure 2-1](#) for more information on how to wire the power supply and attach leads from a configuration device.

**Figure 2-1: Power supply and communicator wiring**



- A. Power supply
- B. Resistor
- C. Ground

### Note

You do not need the resistor if you are connected in one of the following ways:

- AMS Trex (HART® + power)
- AMS Device Configurator Bluetooth® app
- Quick Service buttons
- Local Operator Interface (LOI)

**Table 2-2: Power supply and resistance by communicator type**

Communicator	Power supply	Resistor
AMS Device Manager	≥16.6 Vdc	≥250Ω
AMS Trex (HART)	≥16.6 Vdc	≥250Ω
AMS Trex (HART + pwr)	None	None
AMS Device Configurator Bluetooth® app	≥10.5 Vdc	None

**Table 2-2: Power supply and resistance by communicator type (continued)**

Communicator	Power supply	Resistor
Quick Service buttons	≥10.5 Vdc	None
LOI	≥10.5 Vdc	None

## 2.4.1 Configuring with a Field Communicator

For more detailed information about AMS Trex, see [AMS Trex Device Communicator](#).

As stated in [System readiness](#), it is critical that the latest Device Drivers (DDs) are loaded onto the Field Communicator to ensure full functionality. See [Device Driver \(DD\) menu trees](#).

### Related information

[Device Driver \(DD\) menu trees](#)

## 2.4.2 Configuring with AMS Device Manager

For more detailed information about AMS Device Manager, see the [AMS Device Manager](#) product page.

It is critical that the latest Device Drivers (DDs) are loaded onto the AMS Device Manager to ensure full functionality. See [System readiness](#).

## 2.4.3 Configuring with the AMS Device Configurator Bluetooth app

For more detailed information about the AMS Device Configurator Bluetooth® app, see [Configure via Bluetooth® wireless technology](#).

### Related information

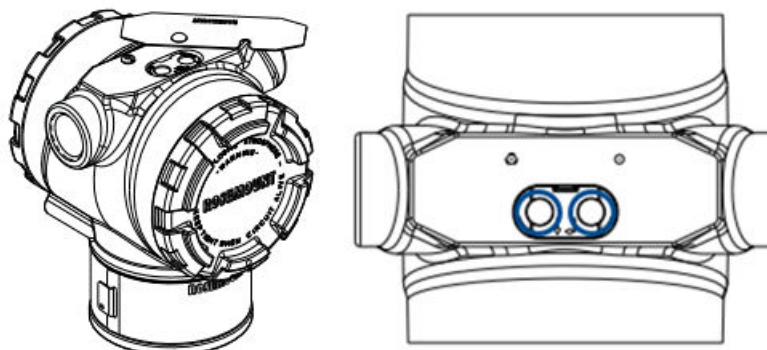
[Device Driver \(DD\) menu trees](#)

## 2.4.4 Configuring with the Quick Service buttons

You can use the Quick Service buttons for the following configuration and maintenance tasks:

- View Configuration
- Zero
- Rerange/Span
- Loop Test
- Flip Screen

**Figure 2-2: Quick Service buttons location**



**Table 2-3: Quick Service buttons operation**

Symbol	Meaning
↓	<ol style="list-style-type: none"> <li>1. Scroll.</li> <li>2. Click the Left button.</li> <li>3. Continue to the next option.</li> </ol>
↙	<ol style="list-style-type: none"> <li>1. Enter.</li> <li>2. Click the Right button.</li> <li>3. Go to the next step or sub menu.</li> </ol>

## NOTICE

**Scroll** and **Enter** buttons are fixed on the left and right of the display respectively, regardless of the display orientation. For 90, 80, and 270 degree rotations, check the symbol on the plastic insert near the button for proper operation.

### Related information

[Quick Service buttons](#)

## 2.4.5 Configure with the Local Operator Interface (LOI)

When using the LOI for configuration, several features require multiple screens for a successful configuration. Data entered is saved on a screen-by-screen basis; the LOI indicates this by flashing **SAVED** on the LCD display each time.

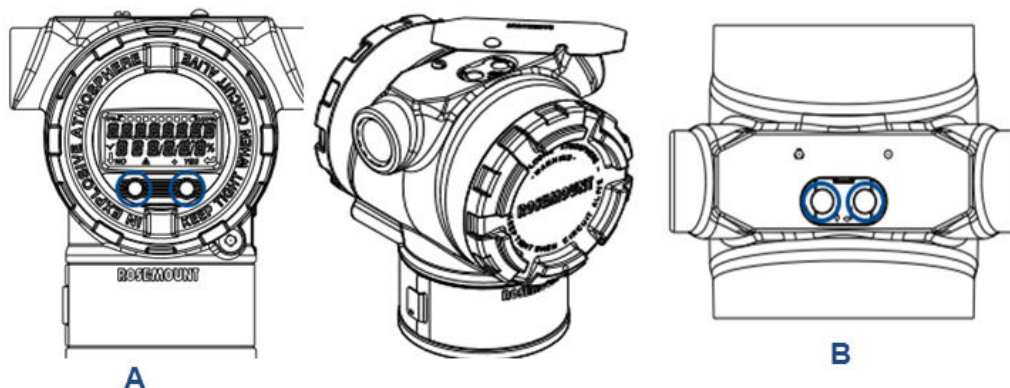
### Procedure

To activate the LOI, push either Configuration button.

Configuration buttons are located on the LCD display<sup>(1)</sup> or underneath the top tag of the transmitter. See [Figure 2-3](#) for configuration button locations and [Table 2-4](#) for configuration button functionality.

<sup>(1)</sup> Remove the housing cover to access the LCD display.

**Figure 2-3: Configuration buttons locations**



- A. Internal configuration buttons
- B. External configuration buttons

**Table 2-4: Configuration button operation**

Symbol	Meaning
↓	Scroll (on the bottom left of the display). Click the Left button. Continue to the next option.
↙	Enter (on the bottom right of the display). Click the right button. Go to the next step or sub menu.
◀   ■   ▶	Progress bar (along the top of the display). Shows how far into the menu you are. The last two options are <b>Back to Menu</b> and <b>Exit Menu</b> . If you continue to press the scroll button after <b>Exit Menu</b> , the menu repeats from the beginning.

LOI menu trees are available in [Local Operator Interface \(LOI\)](#).

## 2.5 How to configure

Each unique application of the Rosemount 3051 may require different steps to commission and configure the transmitter. This section provides an overview of the procedures to perform common configuration tasks on your transmitter.

### 2.5.1 Setting the loop to manual

Whenever sending or requesting data that would disrupt the loop or change the output of the transmitter, set the process application loop to manual control.

The configuration device will prompt you to set the loop to manual when necessary. The prompt is only a reminder; acknowledging this prompt does not set the loop to manual. You must set the loop to manual control as a separate operation.

## 2.5.2 Verifying configuration parameters

Emerson recommends that you verify the following configuration parameters prior to installation into the process:

- Alarm and saturation levels
- Damping
- Process variables
- Range values
- Tag
- Transfer function
- Units

### Verify configuration parameters with a communication device

#### Procedure

1. Go to **Device Settings** → **Setup Overview** → **Alarm and Saturation Values** to set alarm and saturation levels.
2. Go to **Device Settings** → **Setup Overview** → **Output** to set damping.
3. Set the process variables:
  - a) To set the primary variable, go to **Device Settings** → **Output** → **Analog Output** → **PV Setup**.
  - b) To set up the other process variables, go to **Device Settings** → **Communication** → **HART** → **Variable Mapping**.
4. To set range values, go to **Device Settings** → **Output** → **Analog Output** → **PV Setup**.
5. To set a tag, go to **Device Settings** → **Setup Overview** → **Device**.
6. To set transfer function, go to **Device Settings** → **Output** → **Analog Output** → **PV Setup**.
7. Set units.
  - a) To set pressure units, go to **Device Settings** → **Output** → **Pressure** → **Setup**.
  - b) To set other units, go to **Device Settings** → **Output** → **Pressure/Flow/Totalizer/Level/Volume/Module Temperature** → **Setup**.

### Verify configuration parameters with the Quick Service buttons

#### Procedure

1. Locate the external Quick Service buttons.  
See [Figure 2-2](#).
2. Press either button to wake the menu.
3. Press the other button, following the on-screen prompts.
4. Use the **Scroll** and **Enter** buttons go get to the **View Configuration** screen.

## Verify configuration parameters with the Local Operator Interface (LOI)

### Procedure

1. Press either configuration button to activate the LOI.
2. Select **View Config**.

## 2.5.3 Setting pressure units

The pressure unit command sets the unit of measure for the reported pressure.

The procedure is the same for other variables:

- Flow
- Totalizer
- Level
- Volume
- Module Temperature

Select your desired variable and then follow the procedure the procedure below using the desired variable in place of **Pressure**.

### Set pressure units with a communication device

#### Procedure

Go to **Device Settings** → **Output** → **Pressure** → **Setup**.

### Set pressure units with the Local Operator Interface (LOI)

#### Procedure

1. Click either button to activate the LOI.
2. Select **Units**.

## 2.5.4 Setting transmitter output (transfer function)

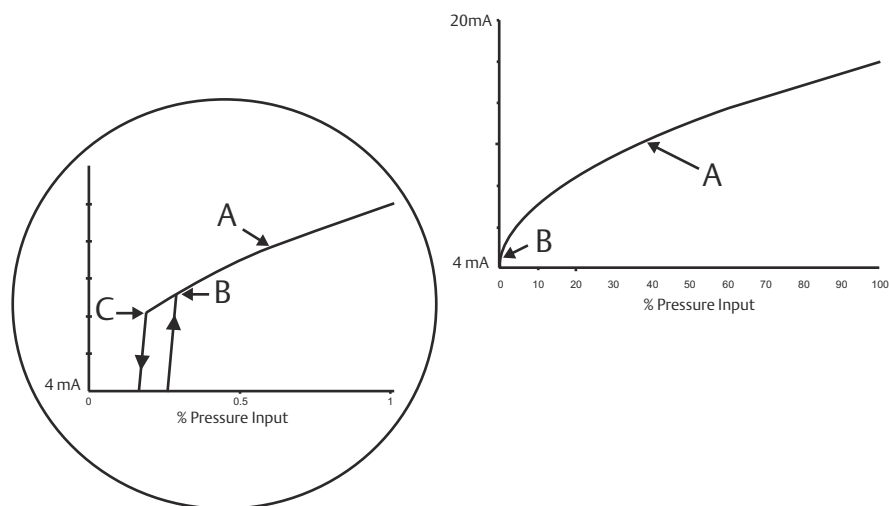
The transmitter has two output settings: Linear and Square root.

As shown in [Figure 2-4](#), activating the square root options makes analog output proportional to flow and includes a fixed Low Flow Cut-off at four percent and a Low Flow Cut-in of five percent of the square root analog output range.

Emerson recommends using application-specific configuration to configure Differential Pressure (DP) flow applications. Refer to [Application specific configuration](#) for setup instructions. When flow rate is assigned to the primary variable, the transfer function will be set to linear in the communication device and cannot be changed to square root. The flow rate variable is automatically set to a square root relationship with respect to pressure.



Figure 2-4: 4-20 mA HART® square root output transition point



- A. Square root curve
- B. 5% transition point
- C. 4% transition point

## Set transmitter output with a communication device

### Procedure

Go to **Device Settings** → **Output** → **Analog Output** → **PV Setup** → **Transfer Function**.

## Set transmitter output with the Local Operator Interface (LOI)

### Procedure

1. Click either button on the transmitter to activate the LOI.
2. Go to **Extended Menu** → **Transfer Funct.**

## 2.5.5 Rerange the transmitter

The range values command sets each of the lower and upper range analog values (4 and 20 mA points) to a pressure. The lower range represents 0 percent of range, and the upper range point represents 100 percent of range.

In practice, you can change the transmitter range values as often as necessary to reflect changing process requirements. For a complete listing of range and sensor limits, refer to the *Specifications* section of the [Rosemount 3051 Product Data Sheet](#).

Select from one of the methods below to rerange the transmitter. Each method is unique; examine all options closely before deciding which method works best for your process.

- Rerange by manually setting range points.
- Rerange with a pressure input source.

## Rerange the transmitter with a communication device

### Procedure

1. Go to **Device Settings** → **Output** → **Analog Output** → **PV Setup**.

2. Do one of the following:
  - Enter range points.
  - Select **Range by Applying Pressure** and follow the prompts.

## Rerange the transmitter with the Quick Service buttons

### Procedure

1. Locate the external buttons.  
See [Figure 2-2](#).
2. Press either button to wake the menu.
3. Press the other button, following the on-screen prompts.
4. Use the **Scroll** and **Enter** buttons to select *Rerange*.

## Rerange the transmitter with the Local Operator Interface (LOI)

### Procedure

1. Click either button to activate the LOI.
2. Select **Rerange**.
3. Do one of the following:
  - Select **Enter Values** to manually enter range points.
  - Select **Apply Values** and follow the prompts to use a pressure input source.

## Rerange with the Zero and Span buttons

### Procedure

1. Locate the external **Zero** and **Span** buttons.
2. Apply transmitter pressure.
3. Rerange the transmitter.
  - To change the zero (4 mA point) while maintaining the span, press and hold the **Zero** button for at least two seconds; then release.
  - To change the span (20 mA) point while maintaining the zero point, press and hold the **Span** button for at least two seconds and then release.

## 2.5.6 Damping

The damping command changes the response time of the transmitter; higher values can smooth variations in output readings caused by rapid input changes.

Determine the appropriate damping setting based on the necessary response time, signal stability, and other requirements of the loop dynamics within your system. The damping command uses floating point configuration, allowing you to input any damping value within 0 - 60 seconds.

### Damping with a communication device

#### Procedure

Go to **Device Settings** → **Output** → [pick the output you want to set damping for (such as **Pressure or Level**)] → **Setup** → **Damping**.

## Damping with the Local Operator Interface (LOI)

### Procedure

1. Click either button to activate the LOI.
2. Go to **Extended Menu** → **Damping**.

## 2.5.7 Configuring the display

### Configuring the LCD display

Customize the LCD display to suit application requirements. The LCD display will alternate between the selected items.

- Pressure
- Module temperature
- Percent of range
- Analog output
- Level
- Volume
- Flow rate
- Totalized flow

### Configure LCD display with a communication device

#### Procedure

Go to **Device Settings** → **Display** → **Display** → **Display Parameters**.

### Configure LCD display with the Local Operator Interface (LOI)

#### Procedure

1. Click either button to activate the LOI.
2. Select **Display**.

### Configuring the graphical LCD display

The graphical LCD display gives you more options to choose from when customizing the display. The display will alternate between the selected items.

- Pressure
- Module temperature
- Percent of range
- Analog output
- Level
- Volume
- Flow rate
- Totalized flow
- HART® long tag

- Alarm switch state
- Security status

### Advanced display settings

You can configure additional settings for the graphical LCD display from the **Advanced display settings tab**.

- Select from eight different languages:
  - English
  - Chinese
  - French
  - German
  - Italian
  - Portuguese
  - Russian
  - Spanish
- Define the type of decimal separator used: comma or period.
- For gauge and absolute transmitters, you can enable a GP or AP unit label. For example, if units are psi and the GP/AP unit label is enabled, then the units will display as `psi-g` or `psi-a` on the graphical display.
- Turn the back light on or off.
- Adjust the number of decimal places on the display up one or down one from the default.

You can use software to rotate the graphical LCD display 180 degrees if the transmitter is mounted upside down. You can also rotate the display manually in 90 degree increments to meet installations requiring a 90 degree or 270 degree rotation.

### Configure the graphical LCD display with a communication device

#### Procedure

Go to **Device Settings** → **Display** → **Display** → **Display Parameters**.

## 2.6 Application specific configuration

### 2.6.1 Configuring for flow rate

With the flow rate configuration, you can create a relationship between the pressure units and user-defined flow units. By defining a pressure at a specific flow rate, the transmitter will perform a square root extraction to convert the pressure reading to a linear flow rate output.

Flow rate configuration includes the following parameters:

- Flow units: User-specified units for flow rate
- Entered flow rate: User-specified flow rate
- Pressure at flow rate<sup>(2)</sup>: User-specified pressure at the entered flow rate.

#### Configure for flow rate with a communication device

##### Procedure

Go to **Device Settings** → **Output** → **Flow** → **Setup** → **Configure Flow**.

#### Configuring low flow cut-off

Emerson highly recommends using the low flow cut-off function to have a stable output and avoid problems due to process noise at a low flow or no flow condition.

There are two key definitions to aid in understanding low flow cut-off:

- |                               |  |
|-------------------------------|--|
| <b>Pressure cut-off value</b> | The pressure at which the field device will stop measuring the flow rate. If the measured pressure is less than the cut-off value, the device will calculate the flow rate to be zero. |
| <b>Pressure cut-in value</b>  | The pressure at which the field device will begin measuring the flow rate. If the measured pressure is more than the cut-in value, the device will begin measuring flow rate.          |

#### Configure low flow cut-off with a communication device

##### Procedure

Go to **Device Settings** → **Output** → **Flow** → **Setup** → **Low Flow Cutoff**

#### Configuring for flow rate example

Use a differential pressure transmitter in conjunction with an orifice plate in a water flow application where the full-scale flow rate is 20,000 US gallons per hour with a differential pressure of 100 inH<sub>2</sub>O at 68 °F. The pressure cut-off and pressure cut-in values for the low flow cut-off will be set to 0.5 inH<sub>2</sub>O at 68 °F.

Based on this information, the configuration would be:

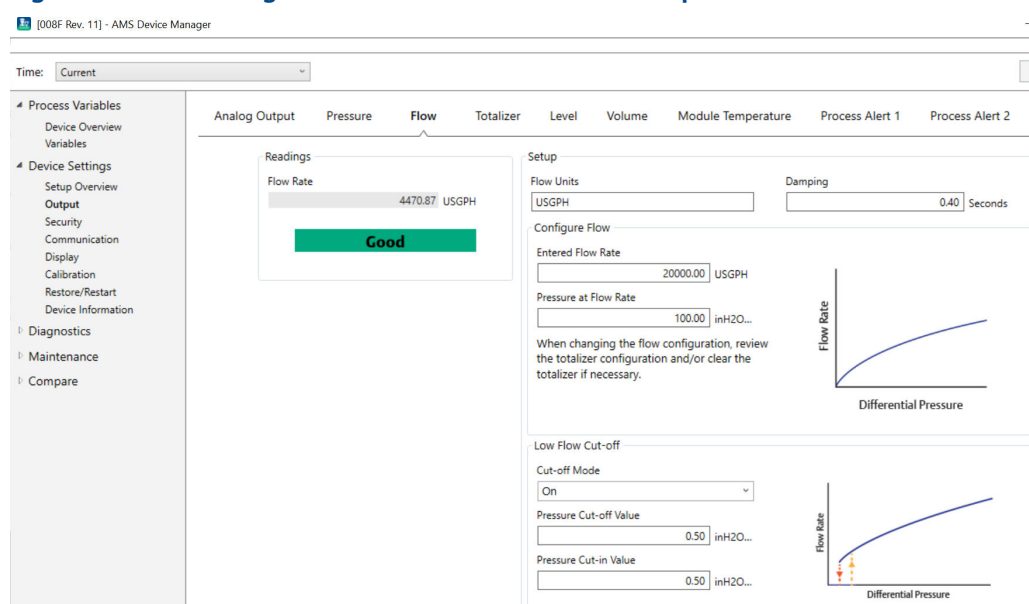
---

(2) You can use the [DP Flow Sizing and Selection Tool](#) to help you establish the relationship between pressure and flow.

**Table 2-5: Entered values for flow rate configuration example**

Parameter	Value
Flow rate units	USGPH
Entered flow rate	20,000 USGPH
Pressure at flow rate	100 inH <sub>2</sub> O at 68 °F
Low flow cut-off	Cut-off mode: On
Pressure cut-off value	0.5 inH <sub>2</sub> O at 68 °F
Pressure cut-in value	0.5 inH <sub>2</sub> O at 68 °F

**Figure 2-5: AMS Configuration screen for flow rate example**



## 2.6.2 Configuring for totalized flow

The flow totalizer will track the amount of flow that has passed your measurement point over time. The totalized flow output tracks the configured flow rate and will require the following inputs:

**Totalizer units** Unit of measure associated with the mass or volume component of the flow rate. Six characters maximum.

**Flow unit of time** Unit of measure associated with the time component of the flow rate.

### Example

For a flow rate of USGPH, the totalizer unit would be USGAL, and the flow unit of time would be hours.

The flow unit is displayed on the communication device for convenience when you configure totalized flow on a communication device.

### Direction

The totalizer can be configured to support the following flow orientations:

**Forward flow** Only tracks flow in the forward direction (positive differential pressure).

**Reverse flow** Only tracks flow in the reverse direction (negative differential pressure).

**Gross flow** Gross flow = Forward flow + Reverse flow

**Net flow** Net flow = Forward flow - Reverse flow

### Max value

The maximum value that the totalizer can measure is displayed.

### Unit conversion factor

Used to define a totalizer specific unit of measure.

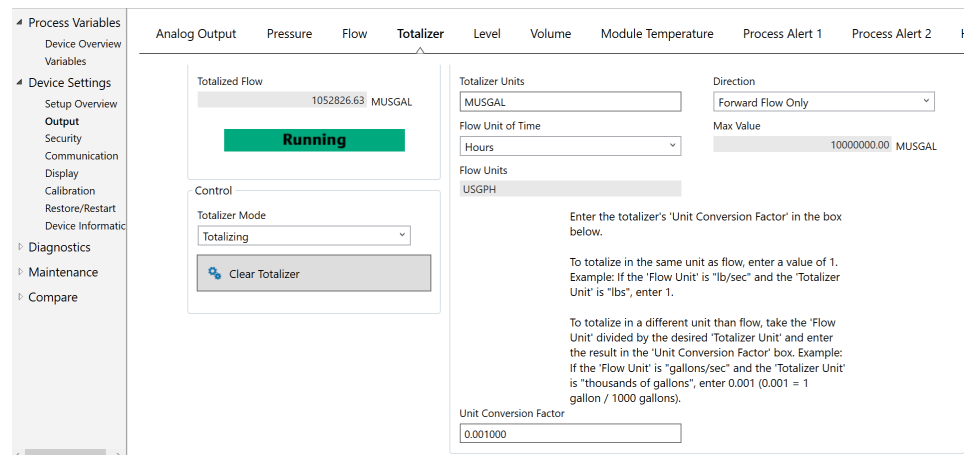
**Example** If the unit you input is USGPH, and your desired totalizer value is thousands of USGAL, MUSGAL, a conversion factor of 0.001 would convert USGAL to MUSGAL. If your desired totalizer value is USGAL, use a unit conversion factor of 1.

## Configure for totalized flow with a communication device

### Procedure

1. Go to **Device Settings** → **Output** → **Totalizer** → **Setup**.

**Figure 2-6: AMS configuration screen for flow totalizer example**



2. Once the totalizer is configured and you are ready to begin totalizing, do the following:
  - a) Go to **Device Settings** → **Output** → **Totalizer** → **Control**.
  - b) Set the **Totalizer Mode** value to **Stopped**.
  - c) Run the **Clear Totalizer** method.
  - d) Set the **Totalizer Mode** value to **Totalizing**.

### Note

If either the hardware **Security** switch or the software Security setting is **On**, it is not possible to clear the totalizer.

## 2.6.3 Configuring for level

With level configuration, you can convert your pressure transmitter to output in level units by creating a relationship between the measured pressure units and the desired level units.

To define this relationship directly, enter the maximum pressure at the maximum level and the minimum pressure at the minimum level.

To simplify configuration and to capture the unique applications that are associated with level measurement, Emerson recommends using the built-in level configurator to quickly and easily configure the transmitter to measure level.

### Level configuration parameters

The level configurator calculates the relationship between pressure and level using the following parameters:

<b>Level units</b>	User-selectable units for level measurement
<b>Tank configuration</b>	Vented or pressurized tank
<b>Technology</b>	Selection is dependent on tank configuration. <ul style="list-style-type: none"> <li>• Capillary remote seal(s)</li> <li>• Direct mount</li> <li>• Impulse piping (wet or dry leg)</li> </ul>
<b>Maximum level</b>	Maximum level that can be measured
<b>Minimum level</b>	Minimum level that can be measured
<b>Process fluid specific gravity</b>	Specific gravity of the process fluid

If applicable:

<b>Pressure tap configuration</b>	Vertical distance between high side process connection and transmitter
<b>Fill fluid</b>	Fill fluid used with remote seal capillary system
<b>Wet leg</b>	Height of low pressure wet leg
<b>Wet leg specific gravity</b>	Specific gravity of the wet leg

### Configure for level

#### Procedure

Go to **Device Settings** → **Output** → **Level** → **Level Configurator**

### Adjust level reading

After configuring level, you can use adjust level reading to change the transmitter level reading to match a desired level. This adjustment can be used to eliminate the effects of various installation variables, such as ambient temperature effects or distance measurement errors.

#### Procedure

Go to **Device Settings** → **Output** → **Level** → **Calibration** → **Adjust Level Reading**.



## Configure for level example

Use a differential pressure Rosemount 3051C with two remote seals on a pressurized tank installation where it will measure level.

The tank has a direct mount seal transmitter on the high side and a low side remote seal with capillary connection with Silicone 200 fill fluid. The process fluid is water with a specific gravity of 1. The transmitter is mounted on the lower tap, which is defined as zero level, and the low-side seal is mounted 10 feet above. The **Level Configurator** method walks you through the configuration to establish the pressure at both minimum and maximum level.

**Figure 2-7: Level Configurator unit information screen**

[008F Rev. 11] - AMS Device Manager

### Level Configurator

Select the following unit information:

Feet

? Next Cancel

**Figure 2-8: Level Configurator tank configuration screen**

[008F Rev. 11] - AMS Device Manager

### Level Configurator

Select the tank configuration:

Pressurized Tank (dual process connection)

? Next Cancel

Figure 2-9: Level Configurator technology screen

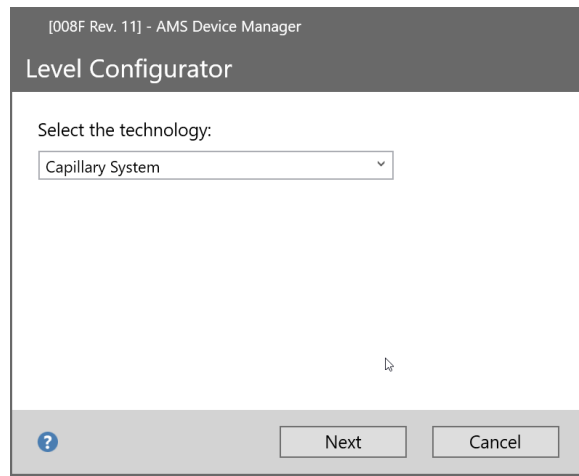
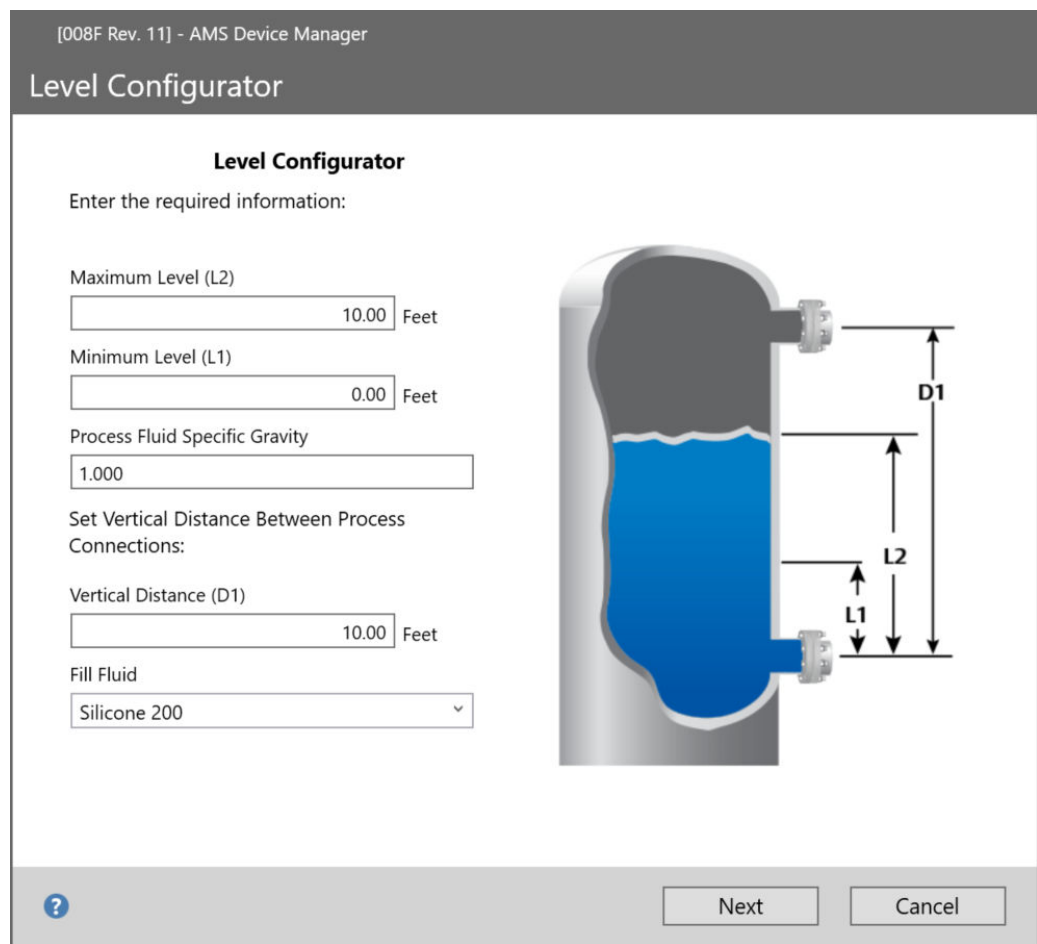
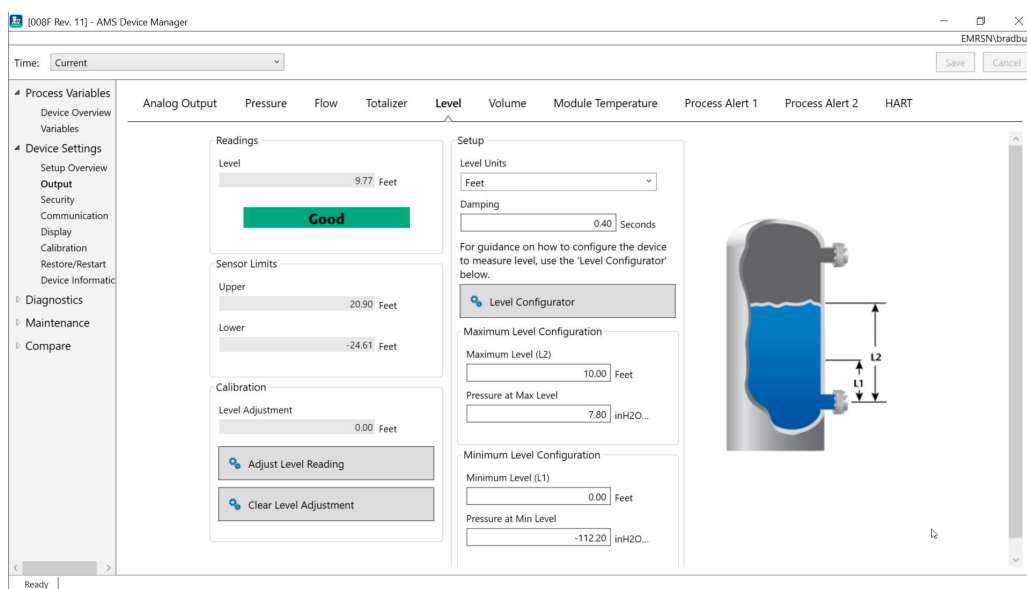


Figure 2-10: Level Configurator Water Return screen



After you complete the Level Configurator method, you can view the **Level Output** screen to confirm that the values are set as expected.

Figure 2-11: Level Output screen



You can use the **Adjust Level Reading** method to adjust the level reading by up to  $(20.90 - (-24.61)) * 0.03 = 1.37$  feet. In this example, you could adjust the level up to 11.14 feet maximum or down to 8.4 feet minimum from its current value of 9.77 feet. To adjust further, you would need to manually update the Minimum Level and/or Maximum Level to correct the output to the desired value.

## 2.6.4 Configuring for volume

Use the Configure Tank method to configure your pressure transmitter to output in volume units.

This method allows you to select from one of five standard tank geometries or to configure the device with a strapping table to create a relationship between level and volume.

### Volume configuration parameters

You can configure volume to use any one of five standard tank geometries to calculate volume as a function of level.

Standard tank geometries assume that zero level is at the geometric bottom of the tank to accurately calculate the volume of the entire tank. If your zero level point is above the geometric bottom of the tank, you can correct your volume reading in one of the following ways:

- Adjust the level reading on the **Level Configuration** window.
- Use a strapping table to configure the level and volume relationship.

The Configure Tank method creates a relationship between level and volume using the following parameters:

- Tank type**      User-selectable tank geometry
- Sphere
  - Vertical bullet

- Horizontal bullet
- Vertical cylinder
- Horizontal cylinder
- Custom

**Volume units** User-selectable units for volume measurement

**Level units** User-selectable units for level measurement. Level unit selection changes in this method will update the level output.

**Tank length (L)** Length of the tank, not required for a sphere or custom tank type

**Tank radius (R)** Radius of the tank, not required for custom tank type

#### Parameters for custom tank type

**Number of strapping points** Number of user-entered points to relate level to volume. 2 minimum and 50 maximum.

**Level and volume** For each strapping point, enter a level and volume.

#### Note

Values for level and volume must be greater than zero. Entries for each strapping point must have increasing values for both level and volume and must not exceed maximum level.

Levels below the level entry on Strapping Point 1 will output the volume on Strapping Point 1. Levels above the highest level on the strapping table will output the highest volume entered. In either case, the volume reading will show a Degraded status to alert you of the problem.

## Configure for volume using a communication device

### Procedure

Go to **Device Settings** → **Output** → **Volume** → **Setup** → **Configure Tank**.

## 2.7 Detailed transmitter setup

### 2.7.1 Configuring alarm and saturation values

In normal operation, the transmitter drives the output in response to pressure from the lower and upper saturation points. If the pressure goes outside of the sensor limits, or if the output would be beyond the saturation points, the output will be limited to the associated saturation point.

The Rosemount 3051 Transmitter automatically and continuously performs self-diagnostic routines. If the self-diagnostic routines detect a failure, the transmitter drives the output to configured alarm and value based on the position of the alarm switch. See [Move Alarm switch](#).

**Table 2-6: Rosemount 3051 alarm and saturation values**

Level	4-20 mA saturation	4-20 mA alarm
Low	3.9 mA	≤ 3.75 mA
High	20.8 mA	≥ 21.75 mA

**Table 2-7: NAMUR-compliant alarm and saturation values**

Level	4-20 mA saturation	4-20 mA alarm
Low	3.8 mA	≤ 3.6 mA
High	20.5 mA	≥ 22.5 mA

**Table 2-8: Custom alarm and saturation values**

Level	4-20 mA saturation	4-20 mA alarm
Low	3.7 - 3.9 mA	3.6 - 3.8 mA
High	20.1 - 22.9 mA	20.2 - 23.0 mA

- Low alarm level must be at least 0.1 mA less than the low saturation level.
- High alarm level must be at least 0.1 mA higher than the high saturation level.

## Configure alarm and saturation values with a communication device

### Procedure

Go to **Device Settings** → **Setup Overview** → **Alarm and Saturation Values** → **Configure Alarm and Saturation Values**.

## Configure alarm and saturation values with the Local Operator Interface (LOI)

### Procedure

1. Click either button to activate the LOI.
2. Go to **Extended Menu** → **Alarm Sat Values**.

## 2.7.2 Configuring process alerts

There are two process alerts that you can configure to use with any dynamic process variable.

Dynamic process variables:

- Pressure
- Flow Rate
- Totalizer
- Level
- Volume
- Module Temperature

The process alerts are independent of each other. You can use these alerts to receive notifications via HART® Status Alert or via Analog Output alarm. Process alerts can be triggered with any dynamic variable, regardless of the HART variable assignments. This means that an Analog Output Alarm can be triggered by any of the dynamic process variables listed above, even if they are not assigned to be the HART primary variable.

## Process alert configuration parameters

Use the Configure Process Alert method to configure each process alert. You can configure the following parameters.

### Notification Mode

Sets the method of notification or disables the process alert.

- Disable Alert
- HART® Status Alert
- Analog Output Alarm

### Monitored Device Variable

The dynamic variable that the process alert tracks.

- Pressure
- Flow Rate
- Totalizer
- Level
- Volume
- Module Temperature

### Activation Trigger

Activates the process alert when the dynamic variable is one of the following:

- Above High Side
- Below Low Side
- Inside Window
- Outside Window

### High Alert Value

When the Monitored Device Variable crosses this high threshold, the process alert will take the configured action. (Not used for Below Low Side activation trigger).

### Low Alert Value

When the Monitored Device Variable value crosses this low threshold, the process alert will take the configured action. (Not used for Above High Side activation trigger).

### Sporadic Alert Reduction

Two different approaches to prevent repeated activation or deactivation of the process alert when the dynamic process variable is fluctuating near one of the alert thresholds.

**Deadband** A user-defined range, entered in the same units as the Monitored Device Variable, beyond the Alert Value trigger when a process alert will not be enunciated.

**Time Delay** A user-defined amount of time (30 seconds maximum) after alert detection when the process alert will not be enunciated.

**Alert Name** The name that will be shown for the alert on the device display.

## NOTICE

The High Alert Value must be higher than the Low Alert Value. Both alert values must be within the range limits of the dynamic process variable.

### Configure process alerts with a communication device

#### Procedure

Go to **Device Settings** → **Output** → **Process Alert (1 or 2)** → **Alert Settings** → **Configure Process Alert (1 or 2)**.

### 2.7.3 Re-mapping device variables

Use the re-mapping function to configure the transmitter primary, secondary, tertiary, and quaternary variables (PV, SV, TV, and QV).

You can use the Local Operator Interface (LOI) to select the primary variable. However, you must use a Field Communicator, AMS Device Manager, or the AMS Device Configurator Bluetooth® app to set the SV, TV, and QV.

#### Note

The variable assigned as the primary variable drives the 4-20 mA output. Possible primary variables include:

- Pressure
- Level
- Volume
- Flow
- Totalizer

### Re-map device variables using a communication device

#### Procedure

1. Select the primary variable by going to **Device Settings** → **Output** → **Analog Output** → **PV Setup** → **Primary Variable**.
2. Map the secondary variable, tertiary variable, and quaternary variable by going to **Device Settings** → **Communication** → **HART** → **Variable Mapping**.

### Re-map the primary variable with the Local Operator Interface (LOI)

#### Procedure

1. Click either button to activate the LOI.
2. Go to **Extended Menu** → **Assign PV**.

## 2.8 Configure via Bluetooth® wireless technology

#### Procedure

1. Launch AMS Device Configurator.

See [AMS Device Configurator for Emerson Field Devices](#).

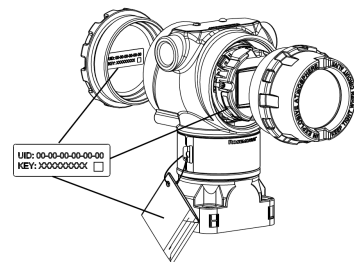
2. Select the device where you want to connect.
3. On first connection, enter the key for selected device.
4. At the top left, select the menu icon to navigate the desired device menu.

## 2.8.1 Bluetooth® UID and key

You can find the Unique Identifier (UID) and key on the disposable paper tag attached to:

- the device
- the terminal block cover
- and on the display unit

**Figure 2-12: Bluetooth security information**



## 2.9 Configuring transmitter diagnostics

The diagnostics and service functions in this section are primarily for use after field installation.

### 2.9.1 Configuring the loop integrity diagnostic

You can use the loop integrity diagnostic to detect issues that may jeopardize the integrity of the electrical loop.

Some examples are:

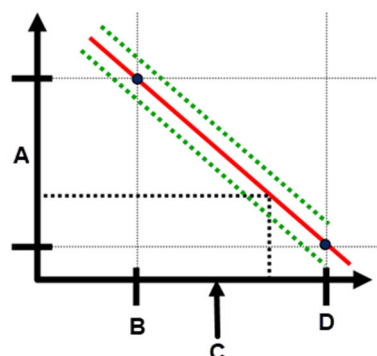
- Water entering the wiring compartment and making contact with the terminals
- An unstable power supply nearing end of life
- Heavy corrosion on the terminals

The technology is based on the premise that once a transmitter is installed and powered up, the electrical loop has a baseline characteristic that reflects the proper installation. If the transmitter terminal voltage deviates from the baseline and outside the user configured threshold, the transmitter can generate a HART® alert or analog alarm.

To use the diagnostic, you must first create a baseline characteristic for the electrical loop after installing the transmitter. The loop is automatically characterized with the push of a button. This creates a linear relationship for expected terminal voltage values along the operating region from 4-20 mA. See [Figure 2-13](#).



Figure 2-13: Baseline operating region



- A. Terminal voltage
- B. 4 mA
- C. Output current
- D. 20 mA

## Overview

Emerson ships the transmitter with **Loop Integrity** off as default and without any loop characterization performed. Once the transmitter is installed and powered up, you must perform a loop characterization for the Loop Integrity diagnostic to function.

When you initiate a loop characterization, the transmitter will check to see if the loop has sufficient power for proper operation. Then the transmitter will drive the analog output to both 4 and 20 mA to establish a baseline and determine the maximum allowable terminal voltage deviation. Once this is complete, you enter a sensitivity threshold called **Terminal Voltage Deviation Limit**, and a check is in place to ensure this threshold value is valid.

Once you have characterized the loop and set the Terminal Voltage Deviation Limit, the Loop Integrity diagnostic actively monitors the electrical loop for deviations from the baseline. If the terminal voltage has changed relative to the expected baseline value, exceeding the configured Terminal Voltage Deviation Limit, the transmitter can generate an alert or alarm.

## NOTICE

The loop integrity diagnostic in the Rosemount 3051 Pressure Transmitter with Advanced HART<sup>®</sup> Diagnostics monitors and detects changes in the terminal voltage from expected values to detect common failures. It is not possible to predict and detect all types of electrical failures on the 4-20 mA output. Therefore, Emerson cannot absolutely warrant or guarantee that the loop integrity diagnostic will accurately detect failures under all circumstances.

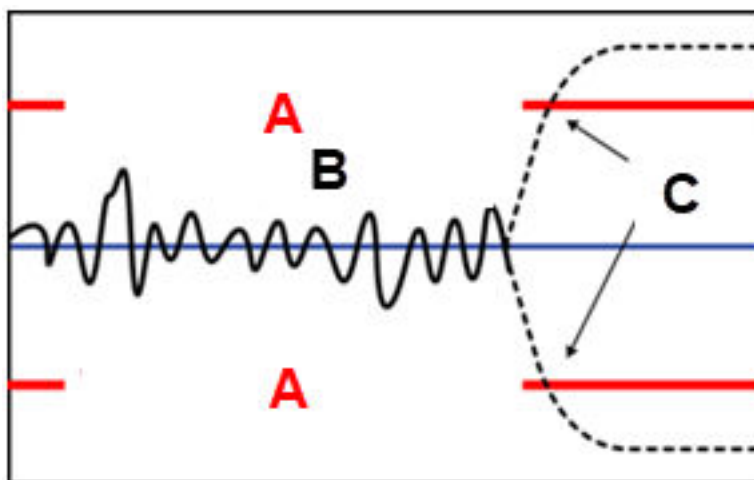
## Terminal voltage

This field shows the current terminal voltage value in volts. the terminal voltage is a dynamic value and is directly related to the mA output value.

## Terminal voltage deviation limit

Set the terminal voltage deviation limit large enough that expected voltage changes do not cause false failures.

Figure 2-14: Voltage deviation limit



- A. Voltage deviation limit
- B. Terminal voltage
- C. Alert

## NOTICE

### Changes in electrical loop

Severe changes in the electrical loop may inhibit HART® communication or the ability to reach alarm values. Therefore, Emerson cannot absolutely warrant or guarantee that the correct Failure alarm level (High or Low) can be read by the host system at the time of annunciation.

## Resistance

This value is the calculated resistance of the electrical loop (in  $\Omega$ s) measured during the characterize loop procedure. Changes in the resistance may occur due to changes in the physical condition of the loop installation. You can compare baseline and previous baselines to see how much resistance has changed over time.

## Power supply

This value is the calculated power supply voltage of the electrical loop (in volts) measured during the characterize loop procedure. Changes in this value may occur due to degraded performance of the power supply. You can compare baseline and previous baselines to see how much the power supply has changed over time.

## Characterize loop

You must initiate loop characterization after installing the transmitter for the first time or after intentionally altering electrical loop characteristics.

Examples include:

- Modifying power supply level or loop resistance of the system
- Changing the terminal block on the transmitter
- Adding the Wireless THUM™ Adapter to the transmitter

---

**Note**

Emerson does not recommend the loop integrity diagnostic for transmitters operating in multidrop mode.

---

### Loop integrity action

When the voltage deviation exceeds the set limit, you can configure three possible actions:

- Disable Diagnostic
- HART® Status Alert
- Analog Output Alarm

The alert or alarm setting is unlatched. If the voltage deviation returns to within the allowed voltage deviation limit due to changes in the loop characteristics, the alert will be cleared from active alerts but will still appear in the diagnostic log.

### Configure loop integrity diagnostic using a communication device

#### Procedure

Go to **Diagnostics** → **Alerts** → **Loop Integrity Diagnostic** → **Settings** → **Configure Loop Integrity**.

## 2.9.2

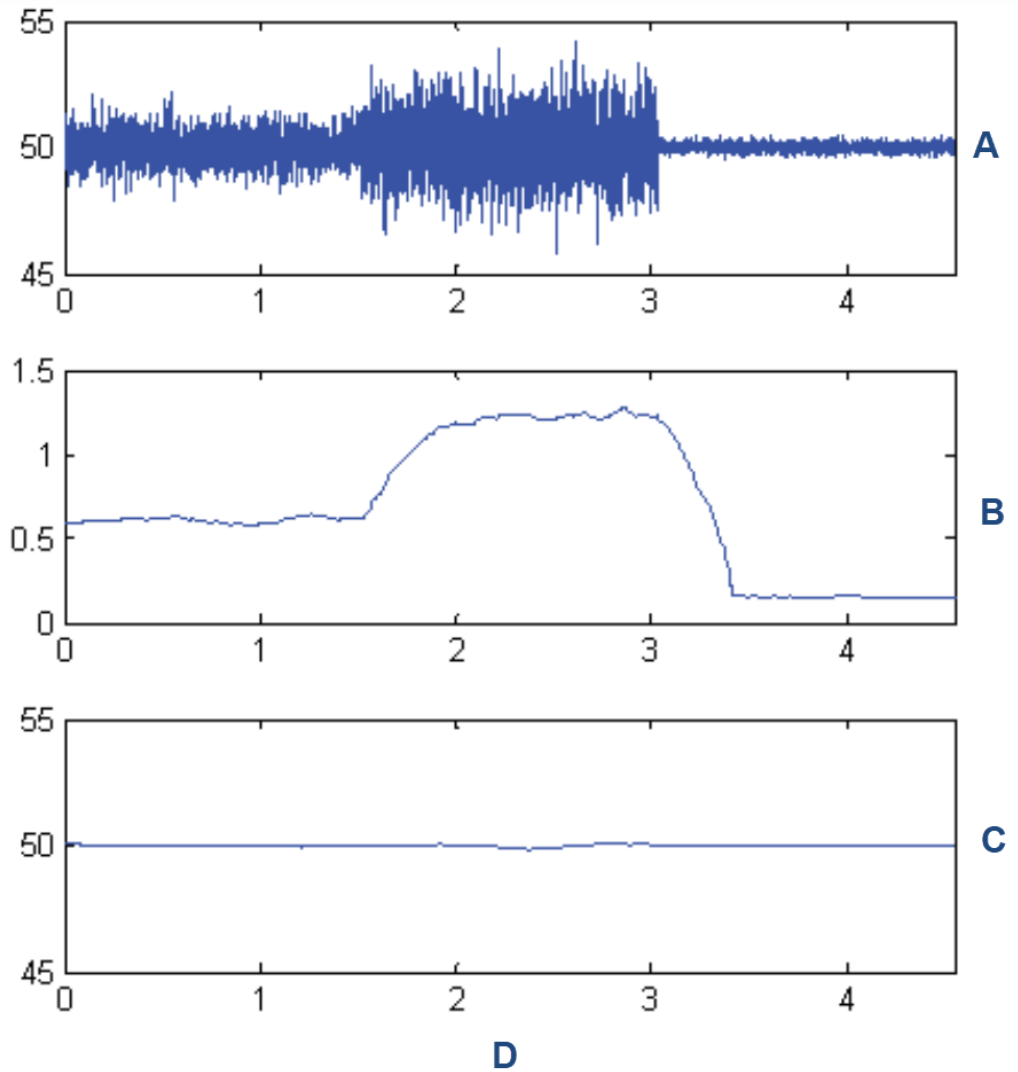
### Configuring plugged impulse line diagnostic

The plugged impulse line diagnostics provides a means to detect plugged impulse lines early.

The technology is based on the premise that all dynamic processes have a unique noise or variation signature when operating normally. Changes in these signatures may signal that a significant change will occur or has occurred in the process. The sensing of the unique signature uses software in the electronics to compute statistical parameters that characterize and quantify the noise or variation. These statistical parameters are the mean, standard deviation, and coefficient of variation (ratio of standard deviation to mean) of the input pressure.

The transmitter has a filtering capability to separate slow changes in the process due to set point changes from the process noise or variation of interest.

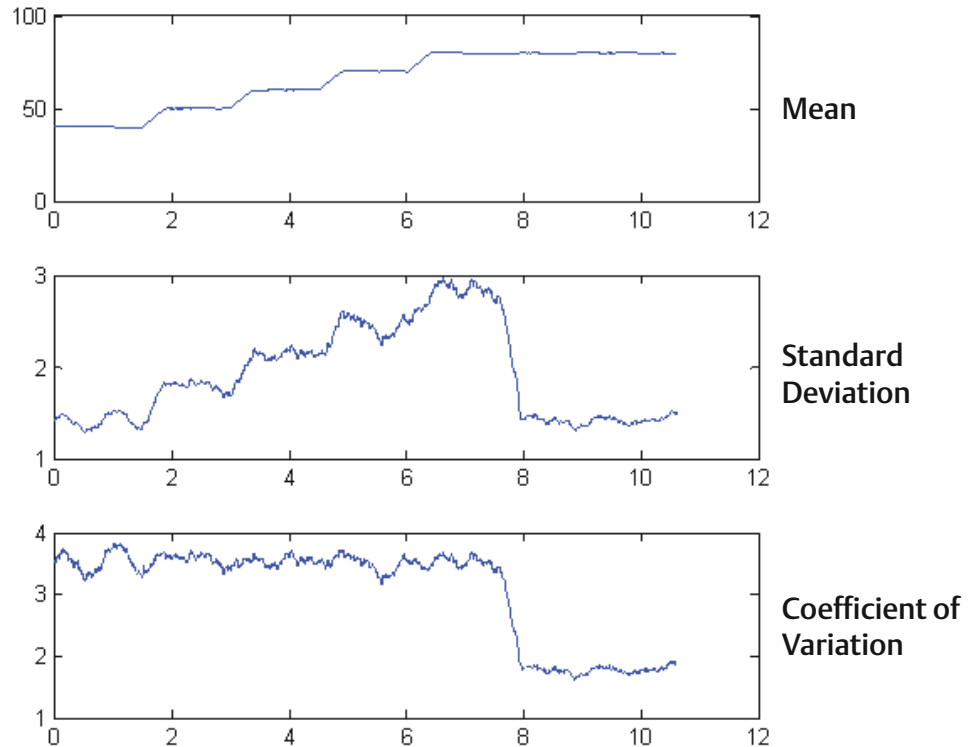
**Figure 2-15: Changes in process noise or variability and effect on statistical parameters**



Standard deviation increases or decreases with changing noise level.

- A. Process noise
- B. Standard deviation
- C. Mean
- D. Time (minutes)

**Figure 2-16: Coefficient of Variation (CV) is the ratio of standard deviation to mean**



CV is stable if mean is proportional to standard deviation.

Typical applications for the plugged line impulse diagnostic include detecting abnormal process connection conditions, such as:

- Plugged impulse lines
- Process leaks
- Coated or plugged Rosemount Annubar

### Configure plugged impulse line diagnostic with a communication device.

To configure the plugged line impulse diagnostic, follow a simple method in the transmitter software.

#### Procedure

1. Go to **Diagnostics** → **Alerts** → **Plugged Impulse Line Diagnostic** → **Settings** → **Configure Plugged Impulse Line Diagnostic**.
2. Select a notification mode:
  - HART® alert
  - Analog Output Alarm
3. Select if the transmitter is installed in a flow application or not.

The software chooses to use the standard deviation or coefficient of variation based on the application. Then the software determines if the transmitter is installed in an active running process, and it will ensure that there is enough noise to configure the diagnostic.

4. Once the diagnostic is configured, you can adjust the level of sensitivity to meet application specific conditions.

You can set the sensitivity at:

- Low
- Medium
- High

## 2.10 Performing transmitter tests

### 2.10.1 Verifying alarm level

If the transmitter electronics board, sensor module, or display is repaired or replaced, verify the transmitter alarm level before returning the transmitter to service. This is useful in testing the reaction of the control system to a transmitter in an alarm state, thus ensuring that the control system recognizes the alarm when activated.

To verify the transmitter alarm values, perform a loop test and set the transmitter output to the alarm value (see [Table 2-6](#) through [Table 2-8](#)).

### 2.10.2 Performing an analog loop test

The analog loop test command verifies the output of the transmitter, the integrity of the loop, and the operations of any recorders or similar devices installed in the loop. Emerson recommends that you verify the 4-20 mA points in addition to alarm levels when installing, repairing, or replacing a transmitter.

The host system may provide a current measurement for the 4–20 mA HART® output. If it does not, connect a reference meter to the transmitter by either connecting the meter to the test terminals on the terminal block or shunting transmitter power through the meter at some point in the loop.

#### Perform an analog loop test using a communication device

##### Procedure

Go to **Diagnostics** → **Simulation** → **Loop Test**.

#### Perform an analog loop test using Quick Service buttons

##### Procedure

1. Locate the external buttons under the top nameplate as shown in [Figure 2-2](#).
2. Press either button to wake the menu.
3. Follow the on-screen prompt by pressing the other button.  
The **Quick Service Button Main Menu** opens.
4. Use the **Scroll** and **Enter** buttons to navigate to the **Loop Test Menu**.

## Perform an analog loop test using the Local Operator Interface (LOI)

### Procedure

1. Click either button to activate the LOI.
2. Select **Loop Test**.

## 2.10.3 Simulating device variables

You can temporarily set the following variables to user-defined fixed values for testing purposes.

- Pressure
- Module temperature

Once the simulated variable method is exited, the transmitter automatically returns the process variable to a live measurement.

### Simulate a device variable with a communication device

#### Procedure

Go to **Diagnostics** → **Simulation** → **Simulate Device Variable**.

## 2.10.4 Simulating primary variable

You can temporarily set the primary variable to user-defined fixed values for testing purposes. Simulating the primary variable drives the digital reading and the analog output to match the user-defined value.

You can set the primary variable to any of the following output variables:

- Pressure
- Level
- Volume
- Flow rate
- Totalized flow

### Simulate primary variable with a communication device

#### Procedure

Go to **Diagnostics** → **Simulation** → **Simulate PV**.

## 2.11 Configuring Burst mode

Burst mode is compatible with the analog signal. Because the HART® protocol features simultaneous digital and analog data transmission, the analog value can drive other equipment in the loop while the control system is receiving digital information.

Burst mode applies only to the transmission of dynamic data and does not affect the way other transmitter data is accessed. However, when activated, Burst mode can slow down communication of non-dynamic data to the host by 50 percent.

The transmitter accesses information other than dynamic transmitter data through the normal poll/response method of HART® Communication. A communication device or the control system may request any of the information that is normally available while the transmitter is in Burst mode. Between each message sent by the transmitter, a short pause allows the communication device to initiate a request.

Message content options:

<b>Cmd 1</b>	Read Primary Variable
<b>Cmd 2</b>	Read Percent Range/Current
<b>Cmd 3</b>	Read Dynamic Variables/Current
<b>Cmd 9</b>	Read Device Variables with Status
<b>Cmd 33</b>	Read Device Variables
<b>Cmd 48</b>	Read Additional Device Status

Trigger mode options:

- Continuous
- Rising
- Falling
- Windowed
- On change

## NOTICE

Consult host system manufacturer for Burst mode requirements.

### 2.11.1 Configure burst mode using a communication device

#### Procedure

Go to **Device Settings** → **Output (or Communication)** → **HART** → **Burst Mode Configuration**.

## 2.12 Establishing multidrop communication

Multidrop communication refers to the connection of several transmitters to a single communications transmission line. Communication between the host and the transmitters takes place digitally with the analog output of the transmitters deactivated.

To install multidrop communication, you must consider the update rate necessary from each transmitter, the combination of transmitter models, and the length of the transmission line. You can communicate with transmitters with HART modems and a host implementing HART protocol. Each transmitter is identified by a unique address and responds to the commands defined in the HART protocol. Field Communicators, the AMS Device Manager, and the AMS Device Configurator Bluetooth® app can test, configure, and format a multidropped transmitter the same way they do for a transmitter in a standard point-to-point installation.

Figure 2-17 shows a typical multidrop network. This figure is not intended as an installation diagram.



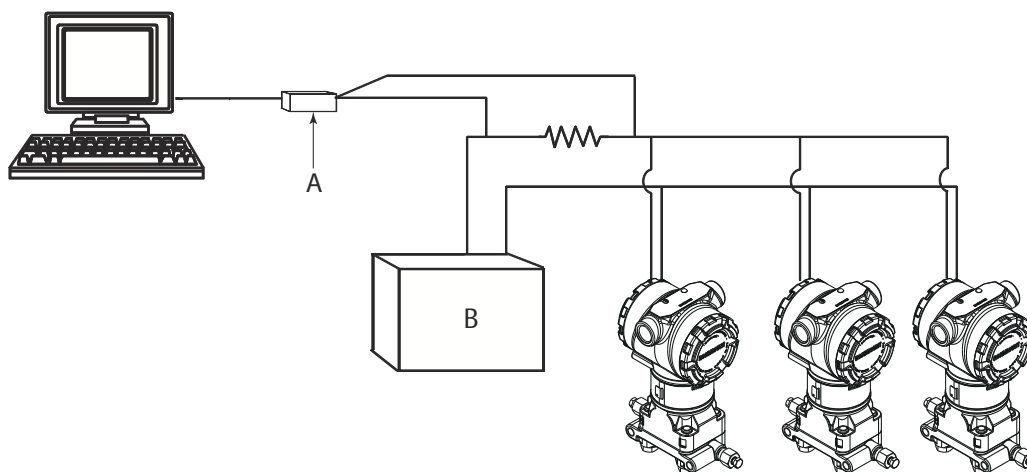
---

**Note**

A multidrop transmitter has a fixed analog output of 4 mA for all but one device. Only one device is allowed to have an active analog signal.

---

**Figure 2-17: Typical multidrop network**



- A. HART® modem
  - B. Power supply
- 

Emerson sets the Rosemount 3051 to address zero (0) at the factory, which allows operation in the standard point-to-point manner with a 4-20 mA output signal. To activate multidrop communication, you must change the transmitter address to a number from 1 to 63. This change deactivates the 4-20 mA analog output, sending it to 4 mA. It also disables the failure mode alarm signal, which is controlled by the upscale/downscale switch position. HART messages communicate failure signals in multidropped transmitters.

## 2.12.1 Changing a transmitter address

To activate multidrop communication, you must assign the transmitter poll address to a number from 1 to 63.

Each transmitter in a multidropped loop must have a unique poll address.

### Change a transmitter address using a communication device

**Procedure**

Go to **Device Settings** → **Output (or Communication)** → **HART** → **Communication Settings** → **Change Polling Address**.

## 2.12.2 Communicating with a multidropped transmitter

To communicate with a multidropped transmitter, set up the Field Communicator or AMS Device Manager for polling.

### Communicate with a multidropped transmitter using a Field Communicator

To set up a Field Communicator for polling:

#### Procedure

1. Go to **Utility** → **Configure HART Application**.
2. Select **Polling Addresses**.
3. Enter **0-63**.

### Communicate with a multidropped transmitter using AMS Device Manager

#### Procedure

1. Click the **HART** modem icon.
2. Select **Scan All Devices**.

## 3 Hardware installation

### 3.1 Overview

The information in this section covers installation considerations for the Rosemount 3051 with HART® protocol. Emerson ships a Quick Start Guide with every transmitter to describe recommended pipe-fitting and wiring procedures for each initial installation.

Dimensional drawings for each Rosemount 3051 variation and mounting configuration are included in [Mounting brackets](#).

#### Related information

[Disassembling the transmitter](#)  
[Reassemble the transmitter](#)

### 3.2 Safety messages

Procedures and instructions in this section may require special precautions to ensure the safety of personnel performing the operation.

Refer to [Safety messages](#).

### 3.3 Considerations

#### 3.3.1 Installation considerations

Measurement accuracy depends upon proper installation of the transmitter and impulse piping. Mount the transmitter close to the process and use a minimum of piping to achieve best accuracy. Keep in mind the need for easy access, personnel safety, practical field calibration, and a suitable transmitter environment. Install the transmitter to minimize vibration, shock, and temperature fluctuation.

#### **⚠ WARNING**

Install the enclosed pipe plug in unused housing conduit opening with a minimum of five threads of engagement to comply with explosion-proof requirements.

For material compatibility considerations, refer to [Material Selection and Compatibility Considerations for Rosemount Pressure Transmitters Technical Note](#).

#### 3.3.2 Environmental considerations

The best practice is to mount the transmitter in an environment that has minimal ambient temperature change.

The transmitter electronics operating temperature limits are -40 to 185 °F (-40 to 85 °C). Refer to the Specifications section in the [Rosemount 3051 Pressure Transmitter Product Data Sheet](#) to view the sensing element operating limits. Mount the transmitter so it is not susceptible to vibration and mechanical shock and does not have external contact with corrosive materials.

### 3.3.3 Mechanical considerations

#### Steam service

For steam service or for applications with process temperatures greater than the limits of the transmitter, do not blow down impulse piping through the transmitter. Flush lines with the blocking valves closed and refill lines with water before resuming measurement. Refer to [Figure 3-9](#) for correct mounting orientation.

#### Side mounted

When the transmitter is mounted on its side, position the coplanar flange to ensure proper venting or draining. Mount the flange as shown in [Figure 3-9](#), keeping drain/vent connections on the bottom for gas service and on the top for liquid service.

### 3.3.4 Draft range considerations

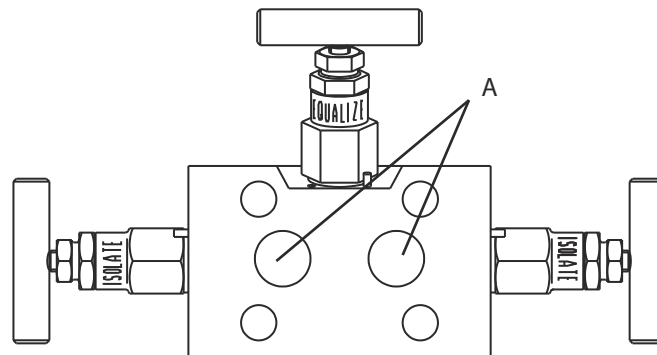
#### Installation

For the Rosemount 3051CD0 Draft Range Pressure Transmitter, Emerson recommends mounting the transmitter with the isolators parallel to the ground.

See [Figure 3-1](#) for a draft range installation example on a Rosemount 304 manifold. Installing the transmitter in this way reduces oil head effect.

Tilting of the transmitter may cause a zero shift in the transmitter output, but you can eliminate this by performing a trim procedure.

**Figure 3-1: Draft range installation example**



A. Isolators

#### Reducing process noise

Rosemount 3051CD0 draft transmitters are sensitive to small pressure changes. Increasing the damping will decrease output noise, but will further reduce response time. In gauge applications, it is important to minimize pressure fluctuations to the low side isolator.

#### Output damping

At the factory, Emerson sets the output damping for the Rosemount 3051CD0 to **3.2**. If the transmitter output is still noisy, increase the damping time. If you need a faster response, decrease the damping time. See [Damping](#) for damping adjustment information.

### Reference side filtering

In gauge applications, it is important to minimize fluctuations in atmospheric pressure to which the low side isolator is exposed.

One method of reducing fluctuations in atmospheric pressure is to attach a length of tubing to the reference side of the transmitter to act as a pressure buffer.

## 3.4 Installation procedures

### 3.4.1 Mount the transmitter

For dimensional drawing information refer to the *Dimensional Drawings* section of the [Rosemount 3051 Product Data Sheet](#).

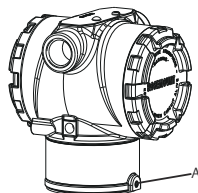
#### Process flange orientation

Mount the process flanges with sufficient clearance for process connections. For safety reasons, place the drain/vent valves so the process fluid is directed away from possible human contact when the vents are used. In addition, consider the need for a testing or calibration input.

#### Rotate housing

You can rotate the electronics housing up to 180 degrees in either direction to improve field access or to better view the optional LCD/Local Operator Interface (LOI) display.

**Figure 3-2: Transmitter housing set screw**



A. Housing rotation set screw (5/64 in.)

#### Procedure

1. Loosen the housing rotation set screw using a 5/64-in. hex wrench.

#### Note

Transmitter damage

- Over-rotating can damage the transmitter.
- Do not rotate the transmitter more than 180 degrees.

2. Turn the housing left or right up to 180 degrees from its original position.<sup>(3)</sup>
3. Re-tighten the housing rotation set screw.

<sup>(3)</sup> Rosemount 3051C original position aligns with **H** side; Rosemount 3051T original position is the opposite side of bracket holes.

## Electronics housing clearance

Mount the transmitter so the terminal side is accessible.

To remove the cover, ensure there is clearance of 0.75 in. (19 mm). Use a conduit plug in the unused conduit opening. You need 3 inches of clearance to remove the cover if a meter is installed.

## Environmental seal for housing

For NEMA® 4X, IP66, and IP68 requirements, use thread sealing (PTFE) tape or paste on male threads of conduit to provide a water and dust tight seal.

Always ensure a proper seal by installing the electronics housing cover(s) so that metal contacts metal. Use Rosemount O-rings.

## Flange bolts

Emerson can ship the Rosemount 3051 with a coplanar flange or a traditional flange installed with four 1.75-in. flange bolts.

See [Table 3-1](#) and [Figure 3-3](#) for mounting bolts and bolting configurations for the coplanar and traditional flanges. Emerson supplies stainless steel bolts coated with a lubricant to ease installation. Carbon steel bolts do not require lubrication. Do not apply additional lubrication when installing either type of bolt. Bolts supplied by Emerson are identified by their head markings.

## Bolt installation

### **⚠ WARNING**

#### Spare parts

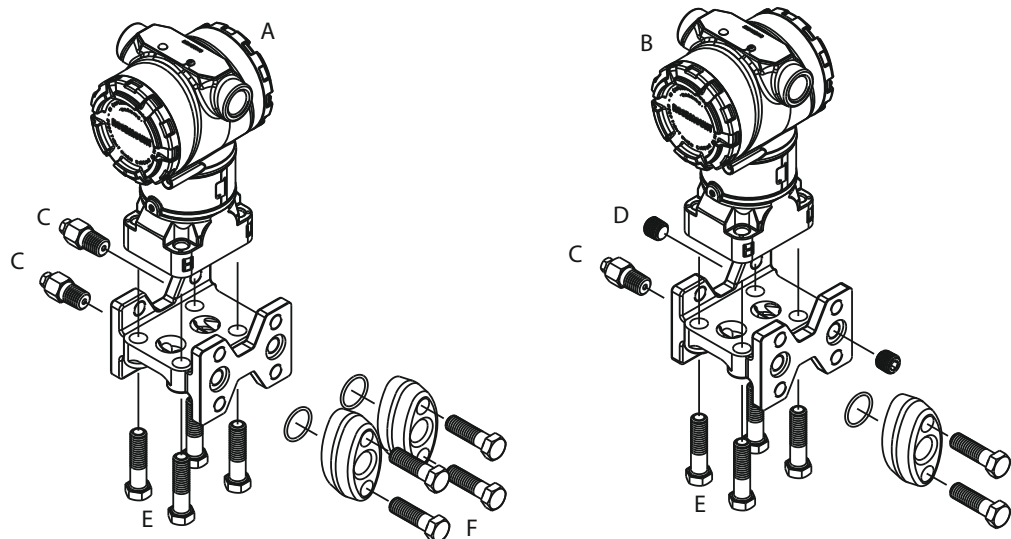
Replacement equipment or spare parts not approved by Emerson for use as spare parts could reduce the pressure retaining capabilities of the transmitter and may render the instrument dangerous.

Use only bolts supplied or sold by Emerson as spare parts.

**Table 3-1: Bolt installation torque values**

Bolt material	Initial torque value	Final torque value
CS-(ASTM-A445) standard	300 in-lb (34 N-m)	650 in-lb (73 N-m)
Austemetic 316 stainless steel (SST)—Option L4	150 in-lb (17 N-m)	300 in-lb (34 N-m)
ASTM A193 Grade B7M—Option L5	300 in-lb (34 N-m)	650 in-lb (73 N-m)

**Figure 3-3: Traditional flange bolt configurations**

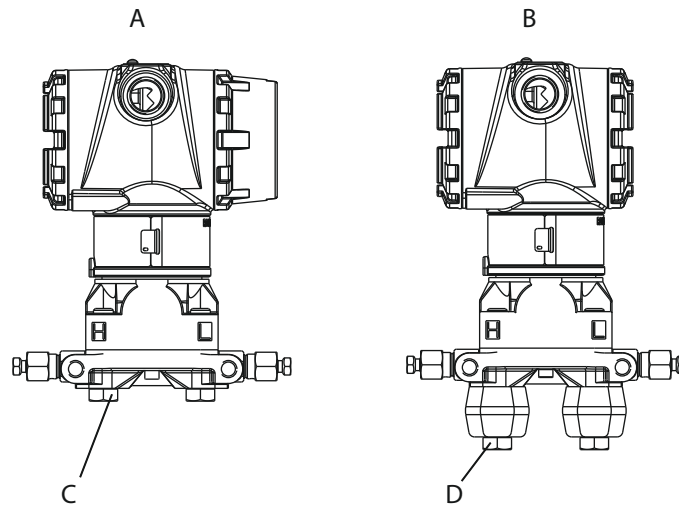


- A. Differential transmitter
- B. Gauge/absolute transmitter
- C. Drain/vent
- D. Vented fitting
- E. 1.75 in. (44 mm) x 4
- F. 1.50 in. (38 mm) x 4<sup>(4)</sup>

Dimensions are in inches (millimeters).

<sup>(4)</sup> For gauge and absolute transmitters: 150 (38) x 2

**Figure 3-4: Mounting bolts and bolt configurations for coplanar flange**



- A. Transmitter with flange bolts
- B. Transmitter with flange adapters and flange/adaptor bolts
- C. 1.75 (44) x 4
- D. 2.88 (73) x 4

**Note**

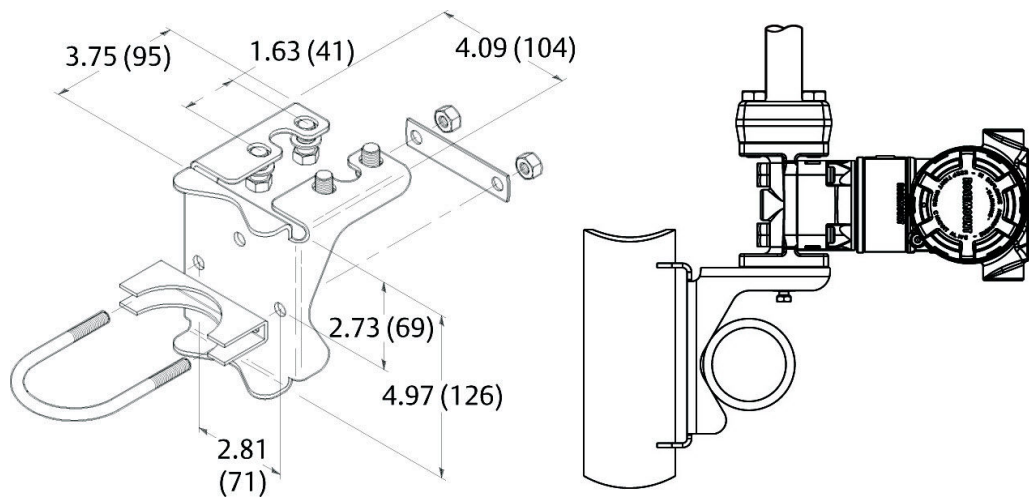
Dimensions are in inches (millimeters).

Description	Quantity	Size in. (mm)
<b>Differential pressure</b>		
Flange bolts	4	1.75 (44)
Flange/adaptor	4	2.88 (73)
<b>Gauge/absolute pressure <sup>(1)</sup></b>		
Flange bolts	4	1.75 (44)
Flange/adaptor bolts	2	2.88 (73)

*(1) Rosemount 3051T Transmitters are direct mount and do not require bolts for process connection.*

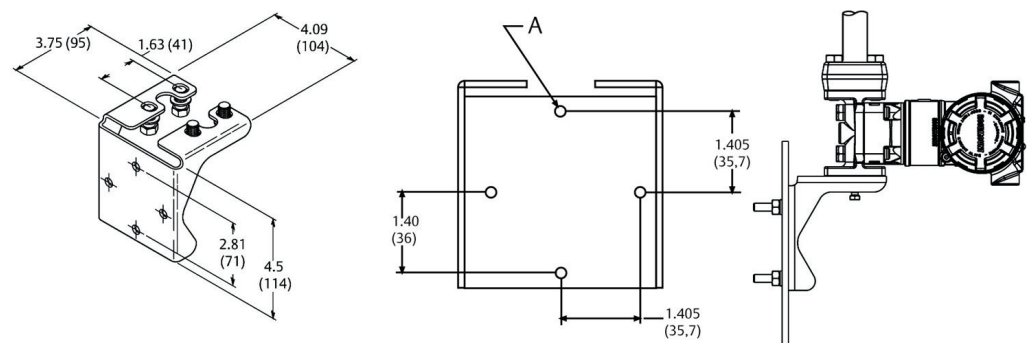


**Figure 3-5: Mounting bracket option codes B1, B7, and BA**



Dimensions are in inches (millimeters).

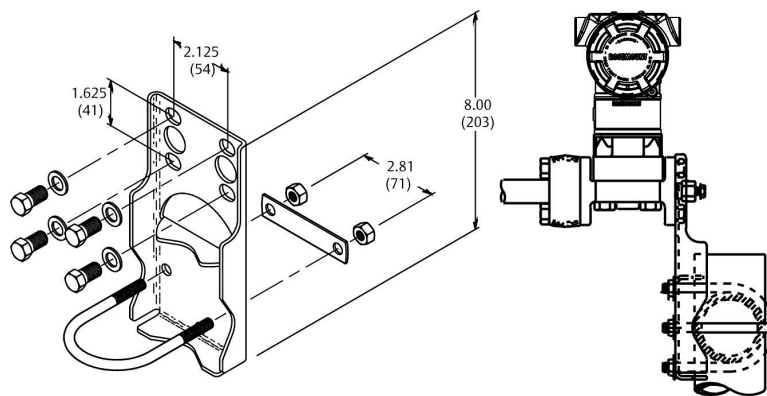
**Figure 3-6: Panel mounting bracket option codes B2 and B8**



A. Mounting holes 0.375 diameter (10)

Dimensions are in inches (millimeters).

**Figure 3-7: Flat mounting bracket option codes B3 and BC**



Dimensions are in inches (millimeters).

1. Finger-tighten the bolts.
2. Torque the bolts to the initial torque value using a crossing pattern (see [Table 3-1](#) for torque values).
3. Torque the bolts to the final torque value using the same crossing pattern.

## Mounting brackets

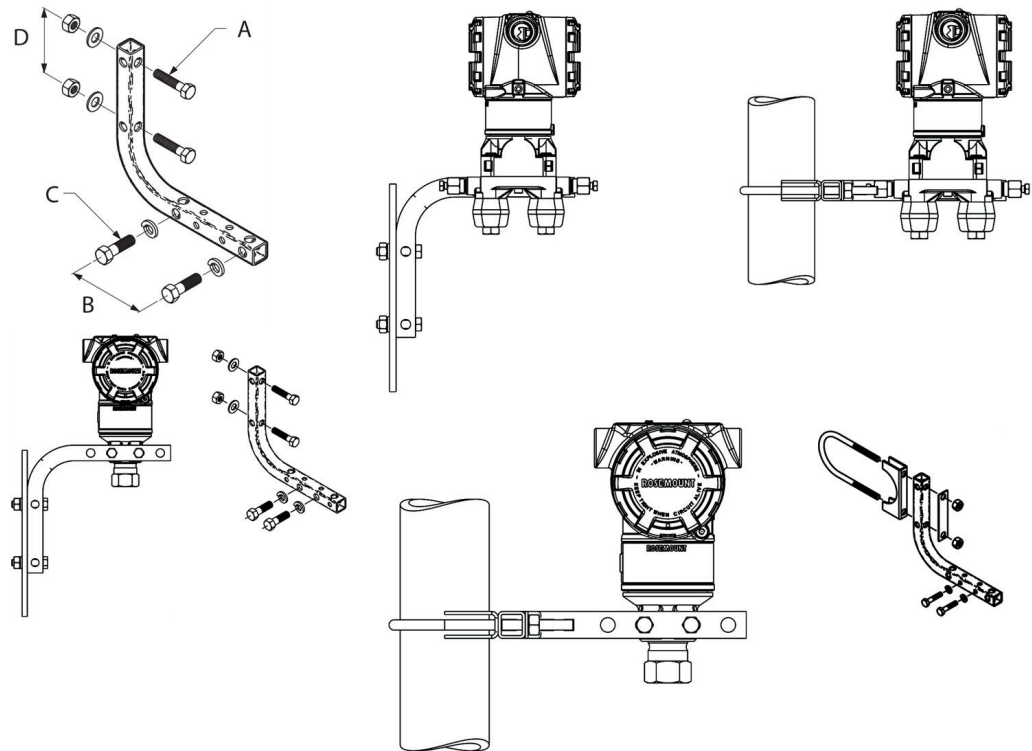
You can use an optional mounting bracket to panel mount or pipe mount the Rosemount 3051 Transmitter.

Refer to [Table 3-2](#) for the complete offering and see [Figure 3-7](#) and [Figure 3-8](#) for dimensional and mounting configuration information.

**Table 3-2: Mounting brackets**

Option code	Process connections			Mounting			Materials			
	Co-planar	In-Line	Traditional	Pipe mount	Panel mount	Flat panel mount	Carbon steel (CS) bracket	Stainless steel (SST) bracket	CS bolts	SST bolts
B4	X	X	N/A	X	X	X	N/A	X	N/A	X
B1	N/A	N/A	X	X	N/A	N/A	X	N/A	X	N/A
B2	N/A	N/A	X	N/A	X	N/A	X	N/A	X	N/A
B3	N/A	N/A	X	N/A	N/A	X	X	N/A	X	N/A
B7	N/A	N/A	X	X	N/A	N/A	X	N/A	N/A	X
B8	N/A	N/A	X	N/A	X	N/A	X	N/A	N/A	X
B9	N/A	N/A	X	N/A	N/A	X	X	N/A	N/A	X
BA	N/A	N/A	X	X	N/A	N/A	N/A	X	N/A	X
BC	N/A	N/A	X	N/A	N/A	X	N/A	X	N/A	X

**Figure 3-8: Mounting bracket option code B4**



- A. 5/16 x 1½-in. bolts for panel mounting (not supplied)
- B. 3.4 (85)
- C. ⅜-in.-16 x 1¼-in. bolts for mounting to transmitter
- D. 2.8 (71)

Dimensions are in inches (millimeters).



Carbon steel (CS) head markings



Stainless steel (SST) head markings

(1)



Alloy K-500 head marking

(1) The last digit in the F593\_ head marking may be any letter between A and M.

## 3.4.2 Impulse piping

### Mounting requirements

Impulse piping configurations depend on specific measurement conditions. Refer to [Figure 3-9](#) for examples of the following mounting configurations:

#### Liquid measurement

- Place taps to the side of the line to prevent sediment deposits on the transmitter's process isolators.
- Mount the transmitter beside or below the taps so gases can vent into the process line.
- Mount drain/vent valve upward to allow gases to vent.

#### Gas measurement

- Place taps in the top or side of the line.
- Mount the transmitter beside or above the taps so liquid will drain into the process line.

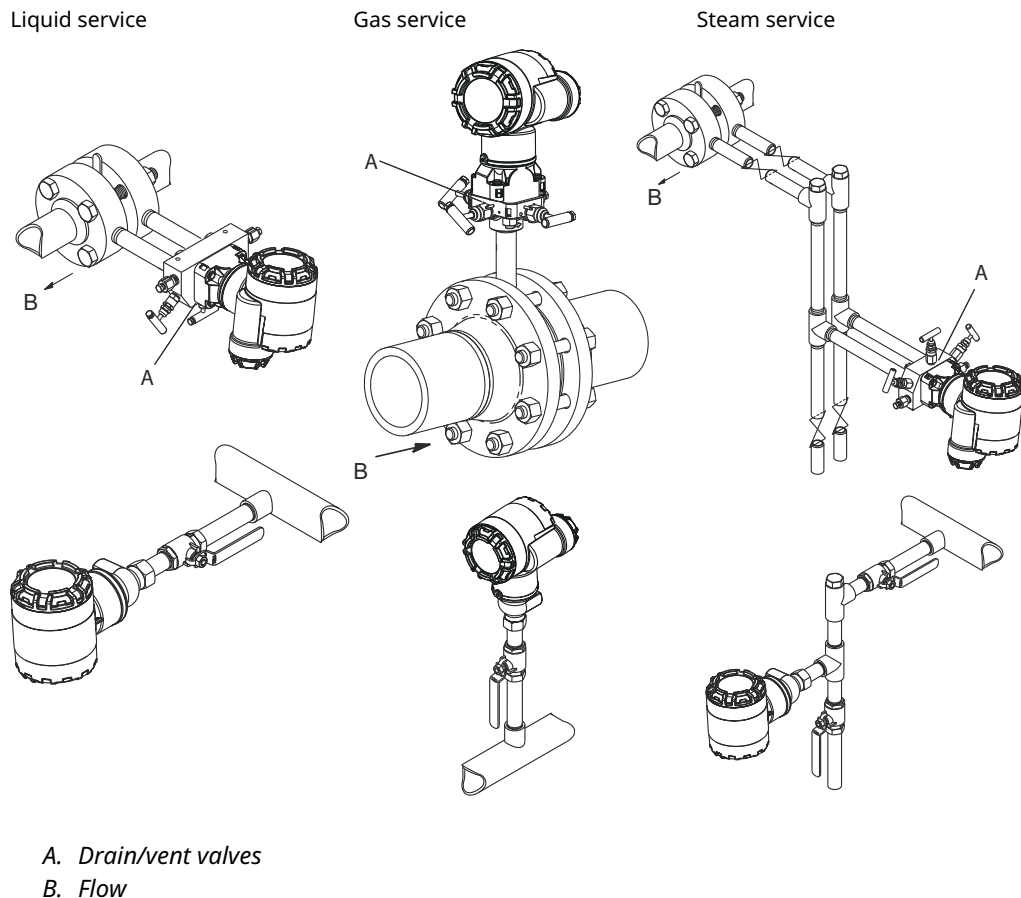
#### Steam measurement

- Place taps to the side of the line.
- Mount the transmitter below the taps to ensure that the impulse piping will stay filled with condensate.
- In steam service above 250 °F (121 °C), fill impulse lines with water to prevent steam from contacting the transmitter directly and to ensure accurate measurement start-up.

### NOTICE

For steam or other elevated temperature services, it is important that temperatures at the process connection do not exceed the transmitter's process temperature limits.

**Figure 3-9: Installation examples**



## Best practices

The piping between the process and the transmitter must accurately transfer the pressure to obtain accurate measurements.

There are six possible sources of error:

- Pressure transfer
- Leaks
- Friction loss (particularly if purging is used)
- Trapped gas in a liquid line
- Liquid in a gas line
- Density variations between the legs

The best location for the transmitter in relation to the process pipe is dependent on the process. Use the following guidelines to determine transmitter location and placement of impulse piping:

- Keep impulse piping as short as possible.

- For liquid service, slope the impulse piping at least 1 in./ft. (8 cm/m) upward from the transmitter toward the process connection.
- For gas service, slope the piping at least 1 in./ft. (8 cm/m) downward from the transmitter toward the process connection.
- Avoid high points in liquid lines and low points in gas lines.
- Ensure impulse legs are the same temperature.
- Use impulse piping large enough to avoid friction effects and blockage.
- Vent all gas from liquid piping legs.
- When using a sealing fluid, fill both piping legs to the same level.
- When purging, make the purge connection close to the process taps and purge through equal lengths of the same size pipe. Avoid purging through the transmitter.
- Keep corrosive or hot (above 250 °F [121 °C]) process material out of direct contact with the sensor modules and flanges.
- Prevent sediment deposits in the impulse piping.
- Maintain equal leg of head pressure on both legs of the impulse piping.
- Avoid conditions that might allow process fluids to freeze within the process flange.

### 3.4.3 Process connections

#### Coplanar or traditional process connection

When properly installed, the flange bolts will protrude through the top of the sensor module housing.

#### Install flange adapters

Rosemount 3051DP and GP process connections on the transmitter flanges are ¼-18 NPT. Flange adapters are available with standard ½-14 NPT Class 2 connections. Use the flange adapters to disconnect from the process by removing the flange adapter bolts.

#### **⚠ WARNING**

##### Process leaks

Process leaks could result in death or serious injury.

Install and tighten all four flange bolts before applying pressure.

Do not attempt to loosen or remove flange bolts while the transmitter is in service.

Use plant-approved lubricant or sealant when making the process connections. Refer to the *Dimensional drawings* section of the [Rosemount 3051 Product Data Sheet](#) for the distance between pressure connections. You can vary the distance by ±¼-in. (6.4 mm) by rotating one or both of the flange adapters.

To install adapters to a coplanar flange:

##### Procedure

1. Remove the flange bolts.

Whenever you remove flanges or adapters, visually inspect the PTFE O-rings. If there are any signs of damage, such as nicks or cuts, replace the O-rings with O-rings designed for Rosemount transmitters. You may reuse undamaged O-rings. If you

replace the O-rings, retorque the flange bolts after installation to compensate for cold flow. Refer to [Reassemble the Rosemount 3051C process flange](#).

## NOTICE

Replace PTFE O-rings if you remove the flange adapter.

2. Leaving the flange in place, move the adapters into position with the O-rings installed.
3. Clamp the adapters and the coplanar flange to the transmitter sensor module using the larger of the bolts supplied.
4. Tighten the bolts.  
Refer to [Flange bolts](#) for torque specifications.

### 3.4.4 Inline process connection

#### Inline gauge transmitter orientation

##### Note

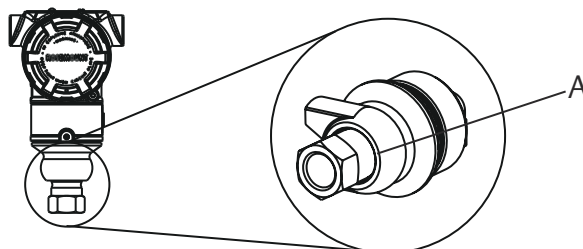
##### Erroneous pressure values

The transmitter may output erroneous pressure values. Do not interfere or block the atmospheric reference port.

The low side pressure port on the inline gauge transmitter is located in the neck of the transmitter, behind the housing. The vent path is 360 degrees around the transmitter between the housing and sensor (see [Figure 3-10](#)).

Keep the vent path free of any obstruction, such as paint, dust, and lubrication, by mounting the transmitter so that the process can drain away.

**Figure 3-10: Inline gauge low side pressure port**



*A. Low side pressure port (atmospheric reference)*

##### Note

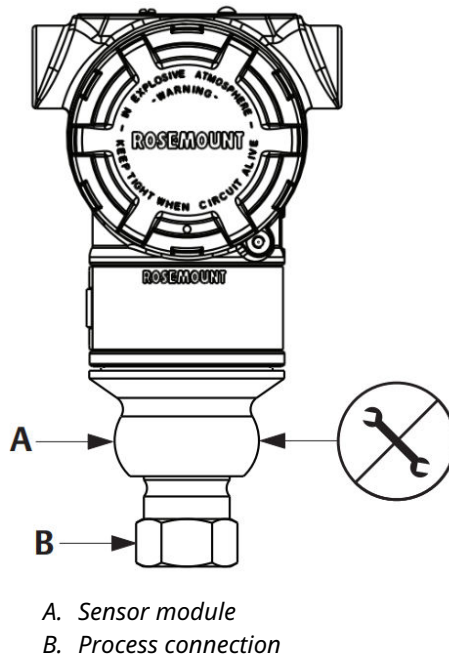
##### Electronics damage

Rotation between the sensor module and the process connection can damage the electronics.

Do not apply torque directly to the sensor module.

To avoid damage, apply torque only to the hex-shaped process connection. See [Figure 3-11](#).

Figure 3-11: Inline gauge



### Install high pressure coned and threaded connection

The transmitter comes with an autoclave connection designed for pressure applications. To connect the transmitter to your process:

#### Procedure

1. Apply a process-compatible lubricant to the gland nut threads.
2. Slip the gland nut onto the tube; then thread the collar onto the tube end.  
The collar is reverse threaded.
3. Apply a small amount of process-compatible lubricant to the tube cone to help prevent galling and facilitate sealing. Insert the tubing into the connection and finger tighten the bolts.
4. Tighten the gland nut to a torque of 25 ft-lb.

#### Note

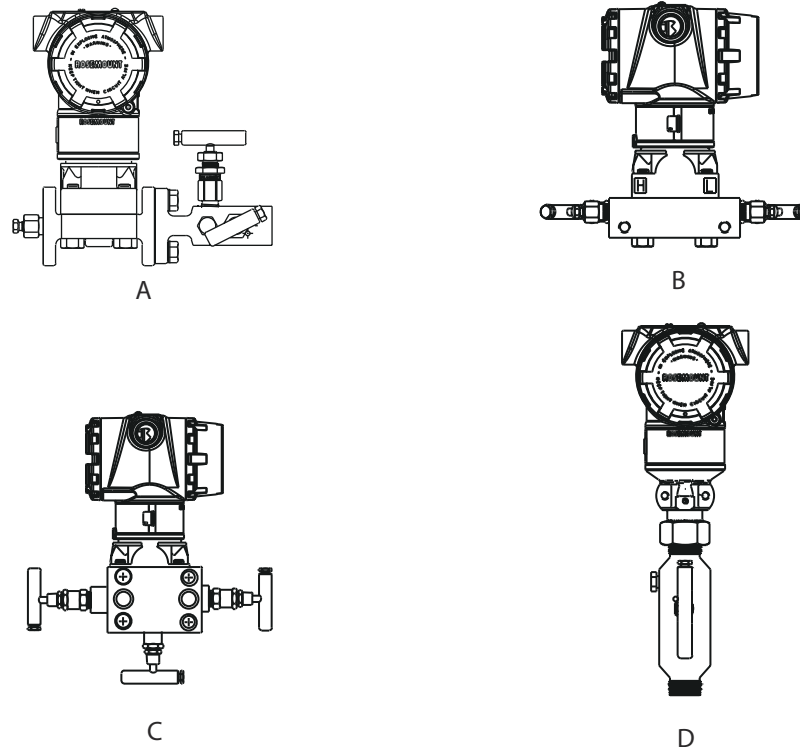
A weep hole has been designed into the transmitter for safety and leak detection. If fluid begins to leak from the weep hole, isolate the process pressure, disconnect the transmitter, and reseal until the leak is resolved.

### 3.4.5 Rosemount 305, 306, and 304 Manifolds

The Rosemount 305 Integral Manifold is available in two designs: Traditional and Coplanar. You can mount the traditional Rosemount 305 Integral Manifold to most primary elements with mounting adapters in the market today.



**Figure 3-12: Manifolds**



- A. Rosemount 3051C and 304 Conventional
- B. Rosemount 3051C and 305 Integral Coplanar
- C. Rosemount 3051C and 305 Integral Traditional
- D. Rosemount 3051T and 306 In-Line

The Rosemount 304 Conventional Manifold combines a traditional flange and manifold that you can mount to most primary elements.

## Install Rosemount 305 Integral Manifold

### Procedure

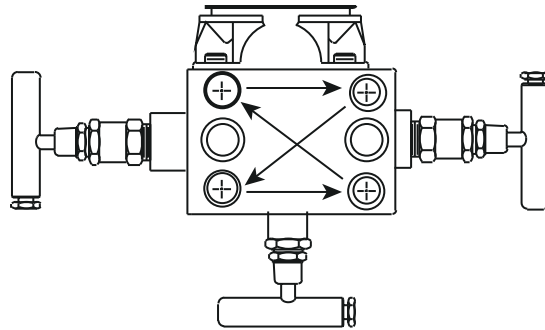
1. Inspect the PTFE sensor module O-rings.  
You may reuse undamaged O-rings. If the O-rings are damaged (if they have nicks or cuts, for example), replace with O-rings designed for Rosemount transmitters.

### Note

If replacing the O-rings, take care not to scratch or deface the O-ring grooves or the surface of the isolating diaphragm while you remove the damaged O-rings.

2. Install the Integral Manifold on the sensor module. Use the four 2.25-in. (57.2 mm). manifold bolts for alignment. Finger-tighten the bolts; then tighten the bolts incrementally in a cross pattern as seen in [Figure 3-13](#) to final torque value.  
See [Flange bolts](#) for complete bolt installation and torque values.  
When fully tightened, the bolts should extend through the top of the sensor module housing.

Figure 3-13: Bolt tightening pattern



3. If you have replaced the PTFE sensor module O-rings, re-tighten the flange bolts after installation to compensate for cold flow of the O-rings.

## Install Rosemount 306 Integral Manifold

Only use the Rosemount 306 Manifold with a Rosemount 3051T In-Line Transmitter.

### **⚠ WARNING**

#### **Process leaks**

Process leaks could result in death or serious injury.

Install and tighten process connectors before applying pressure.

Install and tighten all four flange bolts before applying pressure.

Do not attempt to loosen or remove flange bolts while the transmitter is in service.

Assemble the Rosemount 306 Manifold to the Rosemount 3051T In-Line Transmitter with a thread sealant.

## Install Rosemount 304 Conventional Manifold

See [Safety messages](#).

#### **Procedure**

1. Align the conventional manifold with the transmitter flange. Use the four manifold bolts for alignment.
2. Finger tighten the bolts; then tighten the bolts incrementally in a cross pattern to the final torque value.  
See [Flange bolts](#) for complete bolt installation information and torque values.  
When fully tightened, the bolts should extend through the top of the sensor module housing.
3. Leak-check assembly to maximum pressure range of transmitter.

## Manifold operation

### ⚠ WARNING

#### Process leaks

Process leaks could result in death or serious injury.  
Ensure manifolds are installed and operated correctly.

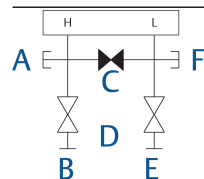
Always perform a zero trim on the transmitter/manifold assembly after installation to eliminate any shift due to mounting effects.

#### Related information

[Sensor trim overview](#)

### Perform a zero trim on three and five-valve manifolds

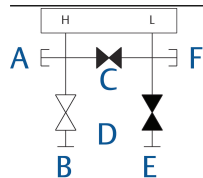
In normal operation, the two block valves between the process and instrument ports are open, and the equalizing valve is closed.



- A. Drain/vent valve
- B. Isolate (open)
- C. Equalize (closed)
- D. Process
- E. Isolate (open)
- F. Drain/vent valve

#### Procedure

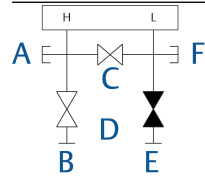
1. To zero the Rosemount 3051, close the block valve to the low pressure (downstream) side first.



- A. Drain/vent valve
- B. Isolate (open)
- C. Equalize (closed)
- D. Process
- E. Isolate (closed)
- F. Drain/vent valve

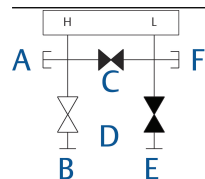
2. Open the center (equalize) valve to equalize the pressure on both sides of the transmitter.

The manifold valves are now in the proper configuration for zeroing the transmitter.



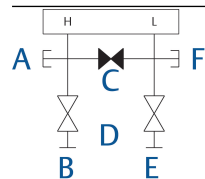
- A. Drain/vent valve
- B. Isolate (open)
- C. Equalize (open)
- D. Process
- E. Isolate (closed)
- F. Drain/vent valve

3. After zeroing the transmitter, close the equalize valve.



- A. Drain/vent valve
- B. Isolate (open)
- C. Equalize (closed)
- D. Process
- E. Isolate (closed)
- F. Drain/vent valve

4. Open the block valve on the low pressure side of the transmitter to return the transmitter to service.

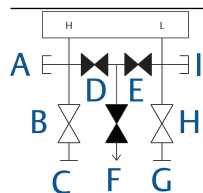


- A. Drain/vent valve
- B. Isolate (open)
- C. Equalize (closed)
- D. Process
- E. Isolate (open)
- F. Drain/vent valve

## Zero a five-valve natural gas manifold

Five-valve natural gas configurations shown:

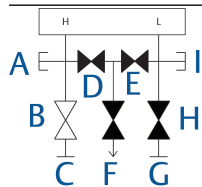
In normal operation, the two block valves between the process and instrument ports will be open, and the equalizing valves will be closed.



- A. Test (plugged)
- B. Isolate (open)
- C. Process
- D. Equalize (closed)
- E. Equalize (closed)
- F. Drain vent (closed)
- G. Process
- H. Isolate (open)
- I. Test (plugged)

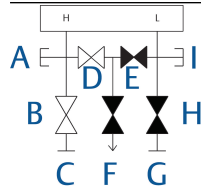
#### Procedure

1. Close the block valve on the low pressure (downstream) side of the transmitter.



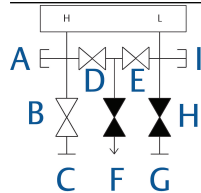
- A. Test (plugged)
- B. Isolate (open)
- C. Process
- D. Equalize (closed)
- E. Equalize (closed)
- F. Drain vent (closed)
- G. Process
- H. Isolate (closed)
- I. Test (plugged)

2. Open the equalize valve on the high pressure (upstream) side of the transmitter.



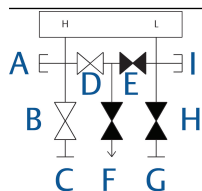
- A. Test (plugged)
- B. Isolate (open)
- C. Process
- D. Equalize (open)
- E. Equalize (closed)
- F. Drain vent (closed)
- G. Process
- H. Isolate (closed)
- I. Test (plugged)

3. Open the equalize valve on the low pressure (downstream) side of the transmitter.  
The manifold is now in the proper configuration for zeroing the transmitter.



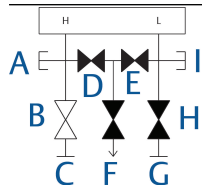
- A. Test (plugged)
- B. Isolate (open)
- C. Process
- D. Equalize (open)
- E. Equalize (open)
- F. Drain vent (closed)
- G. Process
- H. Isolate (closed)
- I. Test (plugged)

4. After zeroing the transmitter, close the equalize valve on the low pressure (downstream) side of the transmitter.



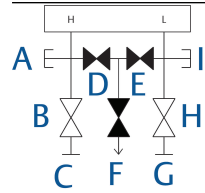
- A. Test (plugged)
- B. Isolate (open)
- C. Process
- D. Equalize (open)
- E. Equalize (closed)
- F. Drain vent (closed)
- G. Process
- H. Isolate (closed)
- I. Test (plugged)

5. Close the equalize valve on the high pressure (upstream) side.



- A. Test (plugged)
- B. Isolate (open)
- C. Process
- D. Equalize (closed)
- E. Equalize (closed)
- F. Drain vent (closed)
- G. Process
- H. Isolate (closed)
- I. Test (plugged)

6. To return the transmitter to service, open the low side isolation valve.



- A. Test (plugged)
- B. Isolate (open)
- C. Process
- D. Equalize (closed)
- E. Equalize (closed)
- F. Drain vent (closed)
- G. Process
- H. Isolate (open)
- I. Test (plugged)



## 4 Electrical installation

### 4.1 Overview

The information in this section covers installation considerations for the Rosemount 3051 Transmitter.

A Quick Start Guide is shipped with every transmitter to describe pipe-fitting, wiring procedures, and basic configuration for initial installation.

#### Related information

[Disassembling the transmitter](#)

[Reassemble the transmitter](#)

### 4.2 Safety messages

Procedures and instructions in this section may require special precautions to ensure the safety of the personnel performing the operations.

See [Safety messages](#).

### 4.3 Install LCD display

Emerson ships transmitters ordered with the LCD display, graphical LCD display, or local operator interface (LOI) options with the display installed.

To install the display on an existing Rosemount 3051 Transmitter:

#### Prerequisites

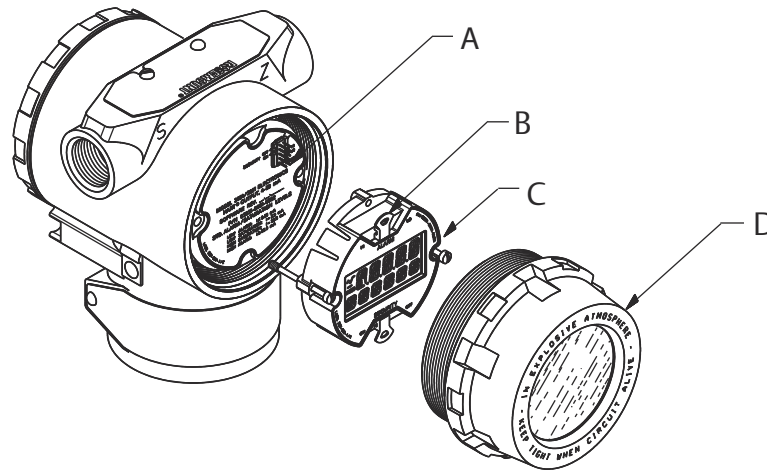
Small instrument screwdriver

#### Procedure

Carefully align the desired display connectors with the electronics board connector.

If the connectors don't align, the display and electronics board are not compatible.

Figure 4-1: LCD display assembly



- A. Interconnecting pins
- B. Jumpers (top and bottom)
- C. Display
- D. Extended cover

### 4.3.1 Rotate display

If you need to rotate the Local Operator Interface (LOI) or LCD display after it has been installed on the transmitter, complete the following steps.

#### Procedure

1. Secure the loop to manual control and remove power to transmitter.

#### **▲ WARNING**

#### **Explosions**

Explosions could result in death or serious injury.

Before connecting a handheld communicator in an explosive atmosphere, ensure that the instruments are installed in accordance with intrinsically safe or non-incendive field wiring practices.

2. Remove transmitter housing cover.
3. Remove screws from the display and rotate it to the desired orientation.
  - a) Insert 10-pin connector into the display board for the correct orientation. Carefully align pins for insertion into the output board.
4. Re-insert screws.
5. Reattach transmitter housing cover.

Ensure that the cover is fully engaged to comply with explosion-proof requirements.
6. Re-attach power and return loop to automatic control.

**Note**

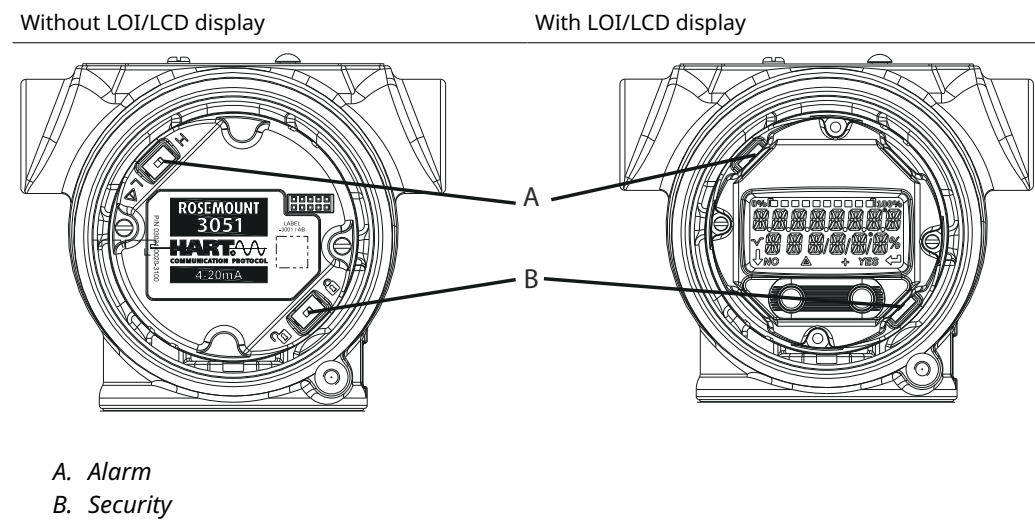
The graphical LCD display can be rotated with the software 180 degrees. You can access this feature with any configuration tool or the Quick Service buttons. For 90 degree and 270 degree orientation, the physical display rotation is still required.

## 4.4 Configuring transmitter security

There are three ways to manage security with the Rosemount 3051 Transmitter.

- Security switch
- Software security
- Local Operator Interface (LOI) password

**Figure 4-2: Electronics board**



### 4.4.1 Enable Security switch

You can enable the **Security** switch to prevent changes to the transmitter configuration data.

If you set the **Security** switch to Locked, the transmitter will reject any configuration requests sent via HART®, Bluetooth®, Local Operator Interface (LOI), or local configuration buttons, and it will not modify the configuration data. See [Figure 4-2](#) for the location of the **Security** switch.

### Procedure

1. If the transmitter is installed, secure the loop and remove power.

#### **⚠ WARNING**

##### **Explosions**

Explosions could result in death or serious injury.

In an explosionproof/flameproof installation, do not remove the transmitter covers when power is applied to the transmitter.

2. Remove the housing cover opposite the field terminal side.

#### **⚠ WARNING**

Do not remove the instrument cover in explosive atmospheres when the circuit is live.

3. Use a small screwdriver to slide the switch to the Lock position.
4. Reattach transmitter housing cover.  
Emerson recommends tightening the cover until there is no gap between the cover and housing to comply with explosion proof requirements.

## 4.4.2 Software security lock

The **software security lock** prevents changes to the transmitter configuration from all sources; it rejects all changes requested via HART®, Bluetooth®, Local Operator Interface (LOI), and local configuration buttons.

Use a communication device to enable or disable the **software security lock**.

## 4.4.3 Local Operator Interface (LOI) password

You can enter and enable an LOI password to prevent review and modification of device configuration via the LOI. This does not prevent configuration from HART or external keys (analog zero and span or digital zero trim).

The LOI password is a four-digit code that you can set. If the password is lost or forgotten, use the master password: 9307.

You can configure and enable or disable the LOI password with HART Communication via a Field Communicator, AMS Device Manager, or the LOI.

## 4.5 Move Alarm switch

There is an **Alarm** switch on the electronics board.

For switch location, see [Figure 4-2](#). Follow the steps below to move the **Alarm** switch:

### Procedure

1. Set loop to Manual and remove power.

## ⚠ WARNING

### Explosions

Explosions could result in death or serious injury.

In an explosionproof/flameproof installation, do not remove the transmitter covers when power is applied to the transmitter.

2. Remove transmitter housing cover.
3. Use a small screwdriver to slide switch to desired position.
4. Replace transmitter cover.  
The cover must be fully engaged to comply with explosion proof requirements.

## 4.6 Electrical considerations

### Note

Ensure all electrical installation is in accordance with national and local code requirements.

## ⚠ WARNING

### Electrical shock

Electrical shock can result in death or serious injury.

Do not run signal wiring in conduit or open trays with power wiring or near heavy electrical equipment.

### 4.6.1 Conduit installation

#### Note

##### Transmitter damage

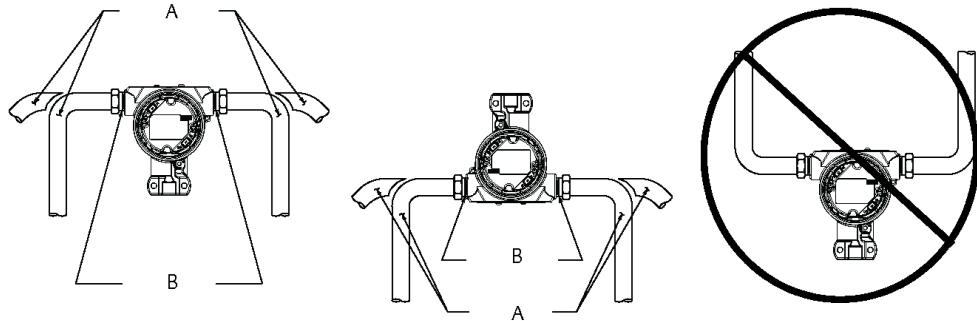
If all connections are not sealed, excess moisture accumulation can damage the transmitter.

Mount the transmitter with the electrical housing positioned downward for drainage.

To avoid moisture accumulation in the housing, install wiring with a drip loop and ensure the bottom of the drip loop is mounted lower than the conduit connections of the transmitter housing.

Figure 4-3 shows recommended conduit connections.

**Figure 4-3: Conduit installation diagrams**



- A. Possible conduit line positions  
B. Sealing compound

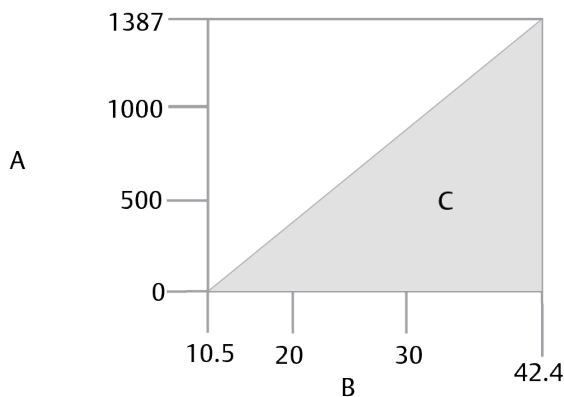
## 4.6.2 Power supply for a 4-20 mA HART®

The transmitter operates on 10.5–42.4 Vdc at the terminal of the transmitter. The DC power supply should provide power with less than two percent ripple. Loops with a 250 Ω resistance require a minimum of 16.6 V.

### Note

The transmitter must have a minimum of 250 Ω to communicate with a Field Communicator. If you are using a single power supply to power more than one Rosemount 3051 Transmitter, ensure the power supply used and the circuitry common to the transmitters do not have more than 20 Ω of impedance at 1200 Hz.

**Figure 4-4: Load limitation**



Maximum loop resistance =  $43.5 \times (\text{power supply voltage} - 10.5)$

- A. Load (Ω)  
B. Voltage (VDC)  
C. Operating region

The total resistance load is the sum of the resistance of the signal leads and the load resistance of the controller, indicator, I.S. barriers, and related pieces. If you use intrinsic safety barriers, include the resistance and voltage drop.

### 4.6.3 Wire the transmitter

**Note**

**Equipment damage**

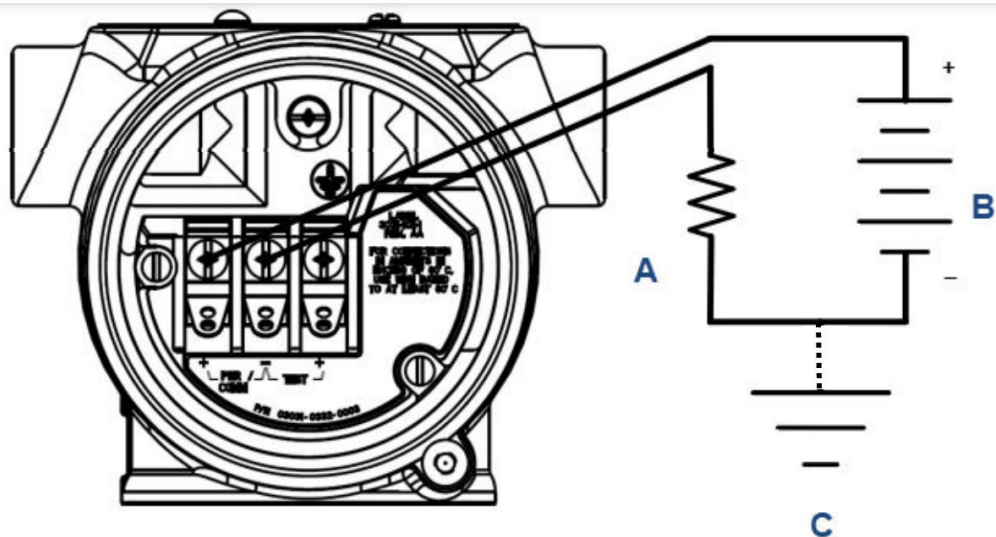
Incorrect wiring can damage test circuit.

Do not connect the power signal wiring to the test terminals.

**Note**

Use shielded twisted pairs to yield best results. To ensure proper communication, use 24 AWG or larger wire and do not exceed 5000 ft (1500 m).

**Figure 4-5: Wiring the transmitter**



- A. Resistor
- B. Power supply
- C. Ground

**Procedure**

1. Remove the housing cover on terminal compartment side.

**⚠ WARNING**

**Explosions**

Explosions could result in death or serious injury.

In an explosionproof/flameproof installation, do not remove the transmitter covers when power is applied to the transmitter.

**Note**

Signal wiring supplies all power to the transmitter.

2. For a 4-20 mA HART® output, connect the positive lead to the terminal marked **pwr/comm+** and the negative lead to the terminal marked **pwr/comm-**.

---

**Note**

**Equipment damage**

Power could damage the test diode.

Do not connect the powered signal wiring to the test terminals.

---

3. Plug and seal unused conduit connections on the transmitter housing to avoid moisture accumulation on the terminal side.

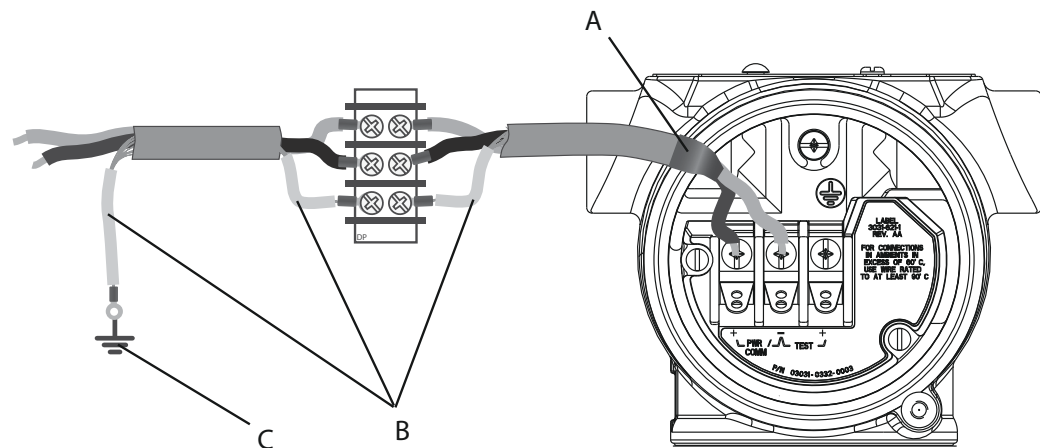
## 4.6.4 Ground signal cable shield

Trim and insulate the signal cable shield and unused shield drain wire to ensure that the signal cable shield and drain wire do not come in contact with the transmitter case.

Figure 4-6 summarizes signal cable shield grounding.

---

**Figure 4-6: Wiring pair and ground**



- A. Insulate shield and shield drain wire.
  - B. Insulate exposed shield drain wire.
  - C. Terminate cable shield drain wire to earth ground.
- 

See [Grounding transmitter case](#) for instructions on grounding the transmitter case.

**Procedure**

1. Remove the field terminals housing cover.
2. Connect the signal wire pair at the field terminals as indicated in [Figure 4-5](#).  
Ensure the cable shield is:
  - Trimmed close and insulated from touching the transmitter housing.
  - Continuously connected to the termination point.
  - Connected to a good earth ground at the power supply end.
3. Reattach the field terminals housing cover.  
The cover must be fully engaged to comply with explosion-proof requirements.  
At terminations outside the transmitter housing, verify the cable shield drain wire is continuously connected.



Prior to the termination point, insulate any exposed shield drain wire as shown in [Figure 4-6](#).

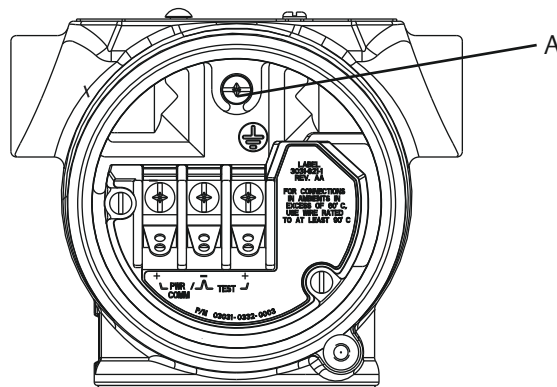
4. Properly terminate the signal cable shield drain wire to an earth ground at or near the power supply.

## Grounding transmitter case

Always ground the transmitter case in accordance with national and local electrical codes. The most effective transmitter case grounding method is a direct connection to earth ground with minimal impedance. Methods for grounding the transmitter case include:

- Internal ground connection: The internal ground connection screw is inside the **FIELD TERMINALS** side of the electronics housing. This screw is identified by a ground symbol (⊕). The ground connection screw is standard on all Rosemount 3051 Transmitters. Refer to [Figure 4-7](#).

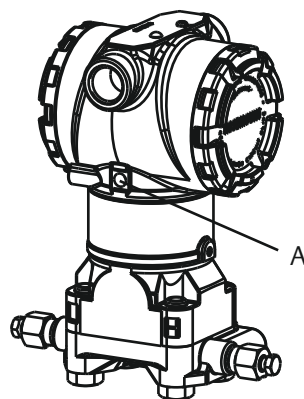
**Figure 4-7: Internal ground connection**



*A. Internal ground location*

- External ground connection: The external ground connection is located on the exterior of the transmitter housing. Refer to [Figure 4-8](#). This connection is only available with option **V5** and **T1**.

**Figure 4-8: External ground connection (option V5 or T1)**



*A. External ground location*

## NOTICE

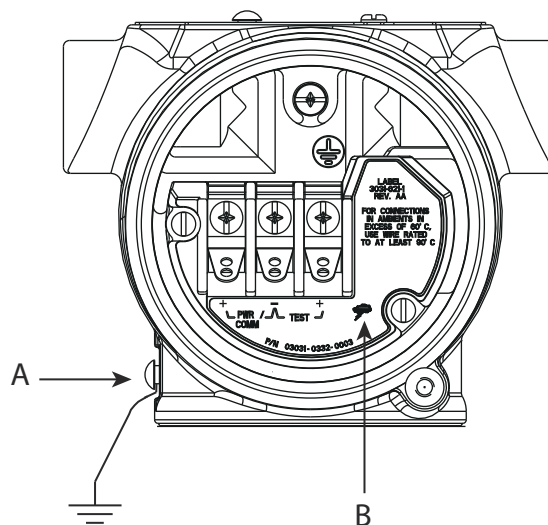
Grounding the transmitter case via threaded conduit connection may not provide sufficient ground continuity.

## Grounding transient protection terminal block

The transmitter can withstand electrical transients of the energy level usually encountered in static discharges or induced switching treatments. However, high-energy transients, such as those induced in wiring from nearby lightning strikes, can damage the transmitter.

You can order the transient protection terminal block as an installed option (option code **T1**) or as a spare part to retrofit existing transmitters in the field. See the *Spare parts* section of the [Rosemount 3051 Product Data Sheet](#) for part numbers. The lightning bolt symbol shown in [Figure 4-9](#) identifies the transient protection terminal block.

**Figure 4-9: Transient protection terminal block**



- A. External ground connection location
- B. Lightning bolt connection

## NOTICE

The transient protection terminal block does not provide transient protection unless the transmitter case is properly grounded. Use the guidelines to ground the transmitter case. Refer to [Figure 4-9](#).

# 5 Operation and maintenance

## 5.1 Overview

---

### Note

#### Calibration

If any trim is done improperly or with inaccurate equipment, it may degrade the transmitter's performance.

Emerson calibrates absolute pressure transmitters (Rosemount 3051CA and 3051TA) at the factory. Trimming adjusts the position of the factory characterization curve.

---

Emerson provides instructions to perform configuration functions with the following:

- Field Communicator
- AMS Device Manager
- AMS Device Configurator Bluetooth® app
- Quick Service buttons
- Local Operator Interface (LOI)

## 5.2 Safety messages

Procedures and instructions in this section may require special precautions to ensure the safety of personnel performing the operations.

See [Safety messages](#).

## 5.3 Recommended calibration tasks

### 5.3.1 Calibrate in the field

#### Procedure

1. Perform sensor zero/lower trim to compensate for mounting pressure effects.  
Refer to [Manifold operation](#) for instructions on properly draining/venting valves.
2. Set/check basic configuration parameters.
  - Output units
  - Range points
  - Output type
  - Damping value

### 5.3.2 Calibrate on a bench

#### Procedure

1. Perform optional 4-20 mA output trim.

2. Perform a sensor trim.
  - a) Zero/lower trim for using line pressure effect correction.  
Refer to [Manifold operation](#) for manifold drain/vent valve operation instructions.
  - b) Perform the optional full scale trim.  
This sets the span of the device and requires accurate calibration equipment.
  - c) Set/check basic configuration parameters.

## NOTICE

To calibrate Rosemount 3051CA and 3051TA range 0 and range 5 devices, you need an accurate absolute pressure source.

## 5.4 Calibration overview

### Note

Emerson fully calibrates the Rosemount 3051 Pressure Transmitter at the factory. Emerson provides a field calibration option to meet plant requirements or industry standards.

### Note

Sensor calibration allows you to adjust the pressure (digital value) reported by the transmitter to be equal to a pressure standard. The sensor calibration can adjust the pressure offset to correct for mounting conditions or line pressure effects. Emerson recommends this correction. To calibrate the pressure range (pressure span or gain correction), you need accurate pressure standards (sources) to provide full calibration.

There are two parts to complete calibration of the transmitter: sensor calibration and analog output calibration.

### Calibrate the sensor

To perform a sensor trim or a digital zero trim, see [Trimming the pressure signal](#).

### Calibrate the 4-20 mA output

- [Performing digital-to-analog trim \(4-20 mA output trim\)](#)

### 5.4.1 Determine necessary sensor trims

With bench calibrations, you can calibrate the instrument for its desired range of operation. Straightforward connections to a pressure source allow for a full calibration at the planned operating points. Exercise the transmitter over the desired pressure range to verify the analog output.

[Trimming the pressure signal](#) discusses how the trim operations change the calibration. It is possible to degrade the performance of the transmitter if a trim is done improperly or with inaccurate equipment. You can set the transmitter back to factory settings using the Recall Factory Trim command shown in [Recall factory trim - sensor trim](#).

For transmitters that are field installed, the manifolds discussed in [Rosemount 305, 306, and 304 Manifolds](#) allow the differential transmitter to be zeroed using the zero trim function. [Rosemount 305, 306, and 304 Manifolds](#) discusses both three-valve and five-valve manifolds. This field calibration eliminates any pressure offsets caused by mounting effects (head effect of the oil fill) and static pressure effects of the process.

To determine the necessary trims:

#### Procedure

1. Apply pressure.
2. Check the pressure. If the pressure does not match the applied pressure, perform a sensor trim.  
See [Trimming the pressure signal](#).
3. Check reported analog output against the live analog output. If they do not match, perform an analog output trim.  
See [Performing digital-to-analog trim \(4-20 mA output trim\)](#).

### Trimming with configuration buttons

Local configuration buttons are external buttons located underneath the top tag of the transmitter that can be used to perform trims.

To access the buttons, loosen screw and rotate top tag until buttons are visible.

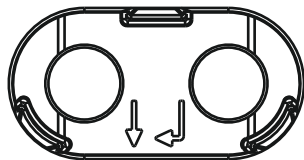
**Configuration buttons** Can perform both digital sensor trim and the 4-20 mA output trim (analog output trim). Use the same procedure to trim with a communication device or AMS.

**Digital zero trim** See [Trimming the pressure signal](#) for trim instructions.

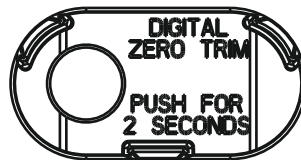
Monitor all configuration changes by looking at a display or by measuring the loop output. [Table 5-1](#) shows the physical differences between the two sets of buttons.

**Table 5-1: Local configuration button options**

Local operator interface (LOI) and Quick Service buttons- green retainer



Digital Zero Trim - gray retainer



## 5.4.2

### Determine calibration frequency

Calibration frequency can vary greatly depending on the application, performance requirements, and process conditions. See [How to Calculate Pressure Transmitter Calibration Intervals Technical Note](#).

#### Procedure

1. Determine the performance required for your application.
2. Determine the operating conditions.
3. Calculate the Total Probable Error (TPE).
4. Calculate the stability per month.
5. Calculate the calibration frequency.

## Sample calculation for Rosemount 3051 (0.04 percent accuracy and 10-year stability)

The following is an example of how to calculate calibration frequency:

### Procedure

1. Determine the performance required for your application.

**Required performance** 0.20% of span

2. Determine the operating conditions.

**Transmitter** Rosemount 3051CD, Range 2 (URL = 250 inH<sub>2</sub>O [6.2 bar])

**Calibrated span** 150 inH<sub>2</sub>O (3.7 bar)

**Line pressure** 500 psig (34.5 barg)

3. Calculate Total Probable Error (TPE).

$$\text{TPE} = \sqrt{(\text{ReferenceAccuracy})^2 + (\text{TemperatureEffect})^2 + (\text{StaticPressureEffect})^2} = 0.105\% \text{ of span}$$

Where:

**Reference Accuracy** ±0.04% of span

**Ambient Temperature Effect**  $\left(\frac{(0,0125 \times \text{URL})}{\text{Span}} + 0,0625\right)\%$  per 50 °F = ±0,0833% of span

**Span Static Pressure Effect** <sup>(5)</sup>  
0,1% reading per 1000 psi (69 bar) = ±0,05% of span

4. Calculate the stability per month.

$$\text{Stability} = \pm \left[ \frac{0,2 \times \text{URL}}{\text{Span}} \right] \% \text{ of span for 10 years} = \pm 0,00278\% \text{ of span for 1 month}$$

5. Calculate calibration frequency.

$$\text{Calibration frequency} = \frac{\text{Req. Performance} - \text{TPE}}{\text{Stability per month}} = \frac{0,2\% - 0,105\%}{0,00278\%} = 34 \text{ months}$$

### 5.4.3 Compensating for span line pressure effects (Range 4 and 5)

Rosemount 3051 Range 4 and 5 Pressure Transmitters require a special calibration procedure when used in differential pressure applications. The purpose of this procedure is to optimize transmitter performance by reducing the effect of static line pressure in these applications.

The Rosemount 3051 Differential Pressure Transmitters (ranges 0 through 3) do not require this procedure because optimization occurs at the sensor.

<sup>(5)</sup> Zero static pressure effect removed by zero trimming at line pressure.

The systematic span shift caused by the application of static line pressure is -0.95 percent of reading per 1000 psi (69 bar) for Range 4 transmitters and -1 percent of reading per 1000 psi (69 bar) for Range 5 transmitters. Using the procedure in [Example](#), you can correct the span effect to ±0.2 percent of reading per 1000 psi (69 bar) for line pressures from 0 to 3626 psi (0 to 250 bar).

## Example

A Range 4 differential pressure HART® transmitter (Rosemount 3051 CD4...) is used in an application with a static line pressure of 1200 psi (83 bar). The transmitter output is ranged with 4 mA at 500 inH<sub>2</sub>O (1.2 bar) and 20 mA at 1500 inH<sub>2</sub>O (3.7 bar). To correct for systematic error caused by high static line pressure, first use the following formulas to determine the corrected values for the high trim value.

### High trim value

$$HT = (URV - [S/100 \times P/1000 \times LRV])$$

Where:

<b>HT</b>	Corrected high trim value
<b>URV</b>	Upper range value
<b>S</b>	Span shift per specification (as percent of reading)
<b>P</b>	Static line pressure in psi.

In this example:

<b>URV</b>	1500 inH <sub>2</sub> O (3.7 bar)
<b>S</b>	-0.95%
<b>P</b>	1200 psi
<b>LT</b>	1500 inH <sub>2</sub> O + (0.95%/100 x 1200 psi/100 psi x 1500 inH <sub>2</sub> O)
<b>LT</b>	1517.1 inH <sub>2</sub> O

Complete the upper sensor trim procedure as described in [Trimming the pressure signal](#). In the preceding example, when calculating the stability per month, apply the nominal pressure value of 1500 inH<sub>2</sub>O Lo. However, enter the calculated correct upper sensor trim value of 1517.1 inH<sub>2</sub>O with a communication device.

## NOTICE

The range values for the 4 and 20 mA points should be at the nominal URV and LRV. In the preceding example, the values are 1500 inH<sub>2</sub>O and 500 inH<sub>2</sub>O respectively. Confirm the values on the **HOME** screen of the Communication device. Modify, if needed, by following the steps in [Rerange the transmitter](#).

## 5.5 Trimming the pressure signal

### 5.5.1 Sensor trim overview

A sensor trim corrects the pressure offset and pressure range to match a pressure standard.

The upper sensor trim corrects the pressure range, and the lower sensor trim (zero trim) corrects the pressure offset. An accurate pressure standard is required for full calibration.

You can perform a zero trim if the process is vented or the high and low side pressure are equal (for differential pressure transmitters).

Zero trim is a single-point offset adjustment. It is useful for compensating for mounting position effects and is most effective when performed with the transmitter installed in its final mounting position. As this correction maintains the slope of the characterization curve, do not use it in place of a sensor trim over the full sensor range.

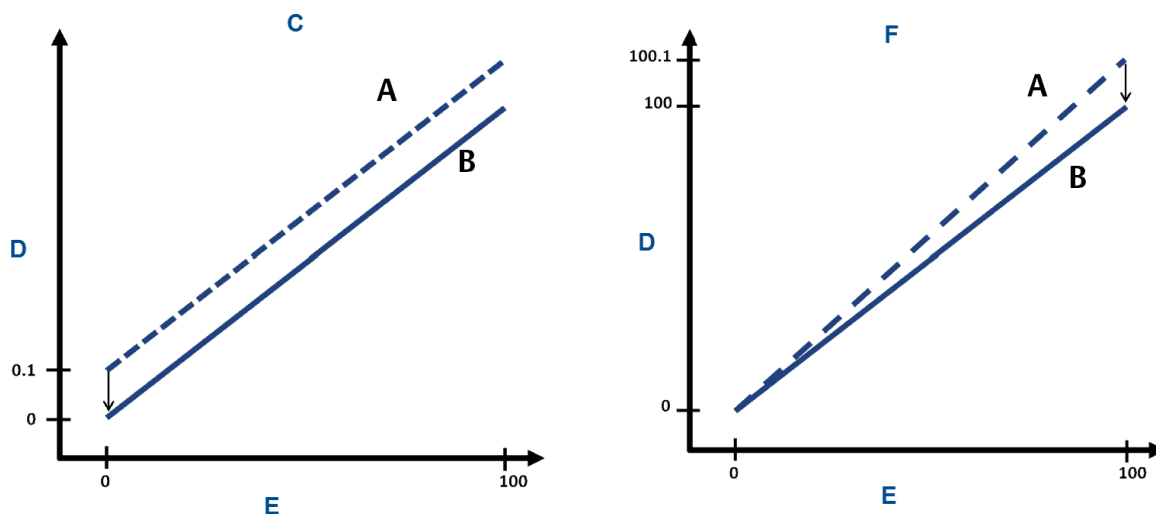
When performing a zero trim, ensure that the equalizing valve is open and all wet legs are filled to the correct levels. Apply line pressure to the transmitter during a zero trim to eliminate line pressure errors. Refer to [Manifold operation](#).

**Note**

Do not perform a zero trim on Rosemount 3051T Absolute Pressure Transmitters. Zero trim is zero based, and absolute pressure transmitters reference absolute zero. To correct mounting position effects on a Rosemount 3051T Absolute Pressure Transmitter, perform a lower sensor trim within the sensor trim function. The lower sensor trim function provides an offset correction similar to the zero trim function, but it does not require zero-based input.

Upper and lower sensor trim is a two-point sensor calibration where two end-point pressures are applied and all output is linearized between them; this calibration also requires an accurate pressure source. Always adjust the low trim value first to establish the correct offset. Adjustment of the high trim value provides a slope correction to the characterization curve based on the low trim value. The trim values help optimize performance over a specific measurement range.

**Figure 5-1: Sensor trim example**



- A. Before trim
- B. After trim
- C. Zero/lower sensor trim
- D. Pressure reading
- E. Pressure input
- F. Upper sensor trim



## 5.5.2 Recall factory trim - sensor trim

You can use the recall factory trim - sensor trim command to restore the as-shipped factory settings of the sensor trim.

This command can be useful for recovering from an inadvertant zero trim of an absolute pressure unit or inaccurate pressure source.

### Recall factory trim with a communication device

#### Procedure

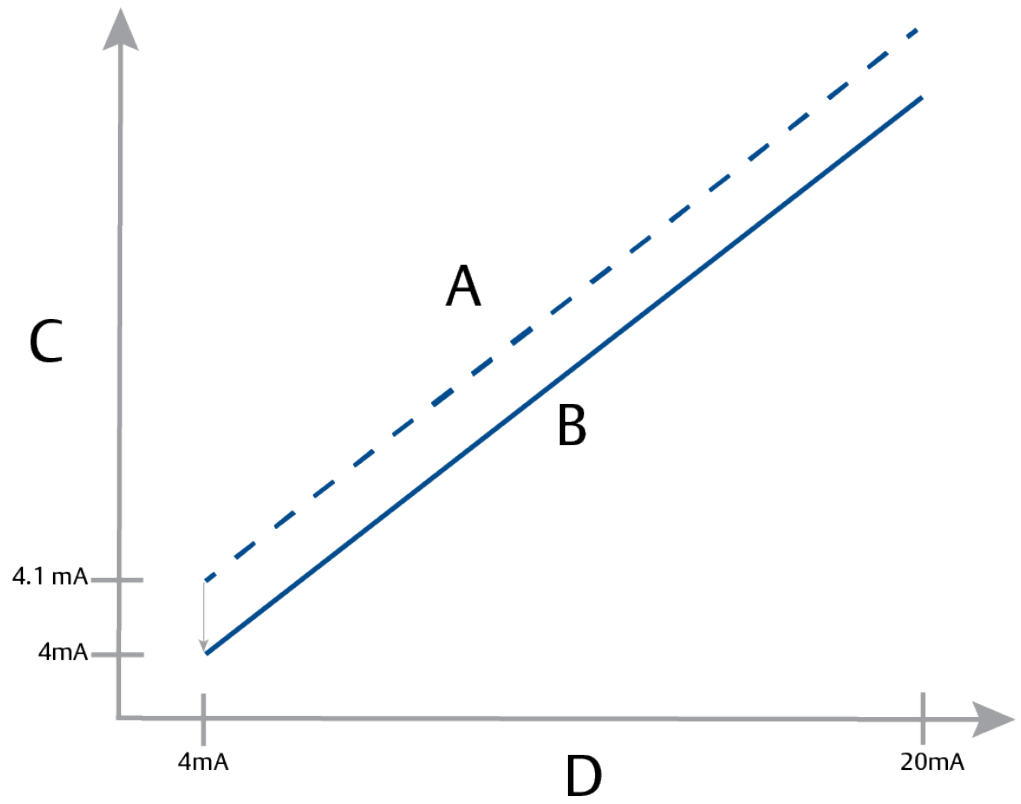
Go to **Device Settings** → **Calibration** → **Pressure** → **Factory Calibration** → **Restore Factory Calibration**.

## 5.6 Trimming the analog output

You can use the analog output trim command to adjust the transmitter's current output at the 4 and 20 mA points to match the plant standards. Perform this trim after the digital to analog conversion, so that it only affects the 4-20 mA analog signal.

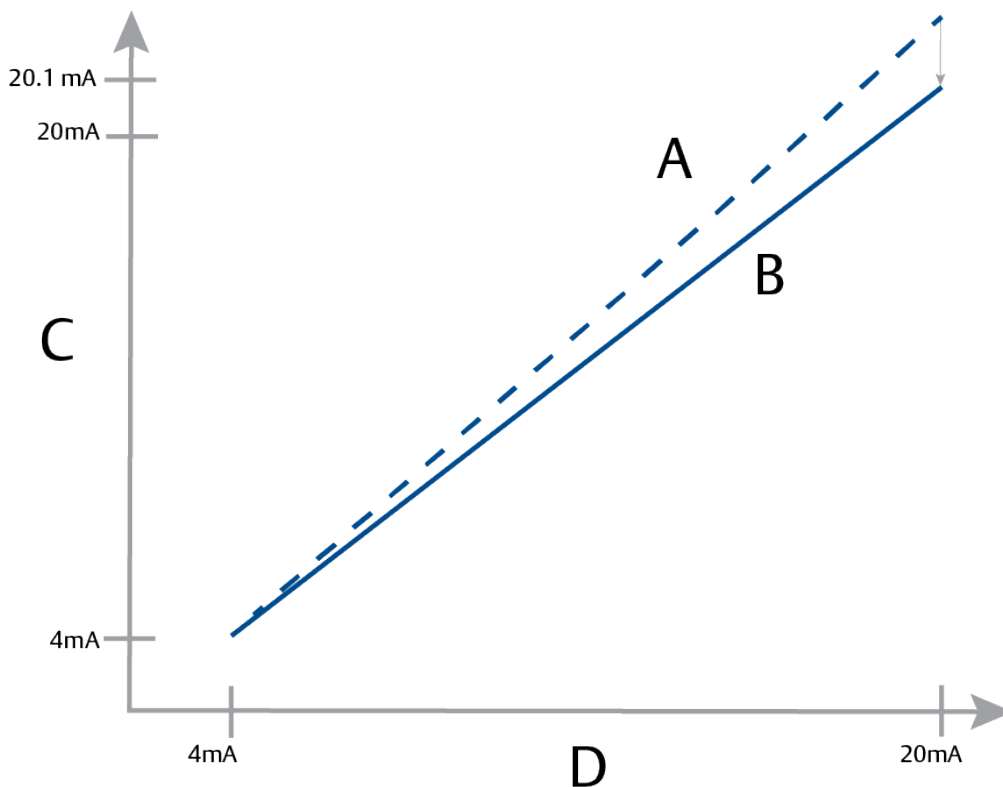
[Figure 5-2](#) and [Figure 5-3](#) graphically show the two ways the characterization curve is affected when an analog output trim is performed.

Figure 5-2: 4-20 mA output trim - zero/lower trim



- A. Before trim
- B. After trim
- C. Meter reading
- D. mA output

Figure 5-3: 4-20 mA output trim - upper trim



- A. Before trim
- B. After trim
- C. Meter reading
- D. mA output

### 5.6.1 Performing digital-to-analog trim (4-20 mA output trim)

#### NOTICE

If you add a resistor to the loop, ensure that the power supply is sufficient to power the transmitter to a 20 mA output with additional loop resistance. Refer to [Power supply for a 4-20 mA HART®](#).

#### Perform a 4-20 mA output trim with a communication device

##### Procedure

Go to **Device Settings** → **Calibration** → **Analog Output** → **Calibration** → **Analog Calibration**.

## 5.6.2 Recalling factory trim - analog output

You can use the recall factory trim - analog output command to restore the as-shipped factory settings to the analog output trim.

This command can be useful for recovering from an inadvertent trim, incorrect plant standard, or faulty meter.

### **Recall factory trim - analog output with a communication device**

#### **Procedure**

Go to **Device Settings** → **Calibration** → **Analog Calibration** → **Factory Calibration** → **Restore Analog Calibration**.

## 6 Troubleshooting

### 6.1 Overview

This section provides summarized troubleshooting suggestions for the most common operating problems.

If you suspect malfunction despite the absence of any diagnostic messages on the Field Communicator display, consider using [Diagnostic messages](#) to identify any potential problem.

### 6.2 Safety messages

Procedures and instructions in this section may require special precautions to ensure the safety of personnel performing the operations.

See [Safety messages](#).

### 6.3 Troubleshooting for 4-20 mA output

#### 6.3.1 Transmitter milliamp reading is zero

##### Recommended actions

1. Verify terminal voltage is 10.5 to 42.4 Vdc at signal terminals.
2. Check power wires for reversed polarity.
3. Check that power wires are connected to signal terminals.
4. Check for open diode across test terminal.

#### 6.3.2 Transmitter not communicating with communication device

##### Recommended actions

1. Verify terminal voltage is 10.5 to 42.2 Vdc.
2. Check loop resistance, 250  $\Omega$  minimum ( $[\text{PS voltage} - \text{terminal voltage}]/\text{loop current}$ ).
3. Check that power wires are connected to signal terminals and not test terminals.
4. Verify clean DC power to transmitter (maximum AC noise 0.2 volts peak to peak).
5. Verify the output is between 4 and 20 mA or saturation levels.
6. Use the communication device to poll for all addresses.

### 6.3.3 Transmitter milliamp reading is low or high

#### Recommended actions

1. Verify applied pressure.
2. Verify 4 and 20 mA range points.
3. Verify output is not in alarm condition.
4. Perform analog trim.
5. Check that power wires are connected to the correct signal terminals (positive to positive, negative to negative) and not the test terminal.

### 6.3.4 Transmitter will not respond to changes in applied pressure

#### Recommended actions

1. Check impulse piping or manifold for blockage.
2. Verify applied pressure is between 4 and 20 mA points.
3. Verify the output is not in Alarm condition.
4. Verify transmitter is not in Loop Test mode.
5. Verify transmitter is not in Multidrop mode.
6. Check test equipment.

### 6.3.5 Digital pressure variable reading is low or high

#### Recommended actions

1. Check impulse piping for blockage or low fill in wet leg.
2. Verify transmitter is calibrated properly.
3. Check test equipment (verify accuracy).
4. Verify pressure calculations for application.
5. Restore pressure calibration. Go to **Device Settings** → **Calibration** → **Pressure** → **Factory Calibration** → **Restore Pressure Calibration**.

### 6.3.6 Digital pressure variable reading is erratic

#### Recommended actions

1. Check application for faulty equipment in pressure line.
2. Verify transmitter is not reacting directly to equipment turning on/off.
3. Verify damping is set properly for application.

### 6.3.7 Milliamp reading is erratic

#### Recommended actions

1. Verify power source to transmitter has adequate voltage and current.
2. Check for external electrical interference.
3. Verify transmitter is properly grounded.
4. Verify shield for twisted pair is only grounded at one end.

## 6.4 Diagnostic messages

The following sections contain possible messages that appear on either the display, a communication device, or an AMS system. Use them to diagnose status messages.

- Failure
- Function Check
- Out of Specification
- Maintenance Required

### 6.4.1 Diagnostic message: Failure

#### Electronics Board Failure

A failure has been detected in the electronics circuit board.

<b>Graphical LCD display</b>	Electronics Board Failure
<b>LCD display</b>	FAIL BOARD
<b>Local Operator Interface (LOI)</b>	FAIL BOARD

##### Recommended action

Replace the electronic circuit board.

#### Sensor Module Failure

A failure has been detected in the sensor module.

<b>Graphical LCD display</b>	Sensor Module Failure
<b>LCD display</b>	FAIL SENSOR
<b>Local Operator Interface (LOI)</b>	FAIL SENSOR

##### Recommended action

Replace the sensor module.

#### No Pressure Updates

There are no pressure updates from the sensor to the electronics.

<b>Graphical LCD display</b>	Sensor Communication Failure
<b>LCD display</b>	NO P UPDATE
<b>Local Operator Interface (LOI)</b>	NO PRESS UPDATE

##### Recommended actions

1. Ensure the sensor cable connection to the electronics is tight.
2. Replace the pressure sensor.

## Incompatible Sensor Module

The electronic circuit board has detected a sensor module that is incompatible with the system.

<b>Graphical LCD display</b>	Incompatible Sensor Module
<b>LCD display</b>	XMTR MSMTCH
<b>Local Operator Interface (LOI)</b>	XMTR MSMTCH

### Recommended action

Replace the incompatible sensor module.

## No Temperature Updates

There are no temperature updates from the sensor to the electronics.

<b>Graphical LCD display</b>	Sensor Communication Failure
<b>LCD display</b>	NO T UPDATE
<b>Local Operator Interface (LOI)</b>	NO TEMP UPDATE

### Recommended actions

1. Ensure the sensor cable connection to the electronics is tight.
2. Replace the pressure sensor.

## 6.4.2 Diagnostic message: Function Check

### Primary or Device Variable Simulated

The primary or device variable is being simulated and does not represent the process measurement.

<b>Graphical LCD display</b>	[Variable] Simulated
<b>LCD Display</b>	(None)
<b>Local Operator Interface (LOI)</b>	(None)

### Recommended action

Restart the device.

### Loop Test Current Fixed

The analog output is fixed and does not represent the process measurement due to the device being set to loop test mode.

<b>Graphical LCD display</b>	Loop Test Current Fixed
<b>LCD display</b>	ANLOG FIXED



**Local Operator Interface (LOI)** ANLOG FIXED

#### Recommended actions

1. Verify that the loop test is no longer required.
2. Disable loop test mode or restart the device.

## 6.4.3 Diagnostic message: Out of Specification

### Pressure Out of Limits

The process pressure has exceeded the transmitter's maximum measurement range.

**Graphical LCD display** Pressure Out of Limits

**LCD display** NO P UPDATE

**Local Operator Interface (LOI)** PRES OUT LIMITS

#### Recommended actions

1. Verify the conditions of the process where the transmitter is installed.
2. Check the transmitter pressure connection to ensure it is not plugged and the isolating diaphragms are not damaged.
3. Replace sensor module.

### Module Temperature Out of Limits

The module temperature has exceeded its normal operating range.

**Graphical LCD display** Module Temperature Out of Limits

**LCD display** TEMP LIMITS

**Local Operator Interface (LOI)** TEMP OUT LIMITS

#### Recommended actions

1. Check the process and ambient temperatures to ensure they are within specifications.
2. Replace the sensor module.

### Loop Current Saturated

The loop current is saturated due to the analog value being outside the saturation value range, or the primary variable is being saturated..

**Graphical LCD display** Loop Current Saturated

**LCD display** ANLOG SAT

**Local Operator Interface (LOI)** ANALOG SAT

#### Recommended actions

1. Verify the conditions of the process where the transmitter is installed.
2. Verify the settings for the 4 mA and 20 mA range points and readjust if necessary.
3. Check the transmitter pressure connection to ensure it is not plugged and the isolating diaphragms are not damaged.
4. Replace the sensor module.

## 6.4.4 Diagnostic message: Maintenance Required

### Process Alert 1

The device has detected a change in the monitored variable that exceeds the configured thresholds for Process Alert 1.

**Graphical LCD display**    Process Alert 1 [Alert Name]

**LCD display**    [Alert Name]

**Local Operator Interface (LOI)**    [Alert Name]

#### Recommended actions

1. Verify that the monitored variable is beyond the alert values.
2. Modify the alert settings or turn off the alert.

### Process Alert 2

The device has detected a change in the monitored variable that exceeds the configured thresholds for Process Alert 2.

**Graphical LCD display**    Process Alert 2 [Alert Name]

**LCD display**    [Alert Name]

**Local Operator Interface (LOI)**    [Alert Name]

#### Recommended actions

1. Verify that the monitored variable is beyond the alert values.
2. Modify the alert settings or turn off the alert.

### Plugged Impulse Line Diagnostic

The plugged impulse line diagnostic has detected a change in process noise levels, which could be attributed to a plugged impulse line, plugged flow element, or agitation loss.

**Graphical LCD display**    Plugged Impulse Line Diagnostic

**LCD display**    Plug Line

**Local Operator Interface (LOI)**    Plugged Line

### Recommended actions

1. Verify the conditions of the process where the transmitter is installed.
2. Check the surrounding equipment and process for the following conditions:
  - Plugged impulse line
  - Plugged flow element
  - Agitation loss

## Button Stuck

At least one button on the transmitter display or in the housing is stuck.

<b>Graphical LCD display</b>	Button Stuck
<b>LCD display</b>	STUCK BUTTON
<b>Local operator interface (LOI)</b>	STUCK BUTTON

### Recommended actions

1. Check that the buttons on the housing are not depressed.
2. Remove the front housing cover (considering hazardous location requirements) and ensure that display buttons (if existing) are not depressed.
3. If the buttons will not be used, disable them.
4. Replace the display if it contains buttons.
5. Replace the electronic circuit board.

## Display Communication Failure

The electronic circuit board has lost communication with the display. Note that the contents being displayed may not be correct.

<b>Graphical LCD display</b>	N/A
<b>LCD display</b>	N/A
<b>Local operator interface (LOI)</b>	N/A

### Recommended actions

1. Remove the front housing cover (considering hazardous location requirements) and check that the display assembly is properly seated and connected to the electronic circuit board.
2. Replace the display.
3. Replace the electronic circuit board.

## Loop Integrity Diagnostic

The Loop Integrity Diagnostic has detected a deviation of the terminal voltage outside of the configured limits. This may indicate degraded or loop integrity.

<b>Graphical LCD display</b>	Loop Integrity Diagnostic
------------------------------	---------------------------

**LCD display** POWER ADVISE

**Local Operator Interface (LOI)** POWER ADVISE

#### Recommended actions

1. Check the DC power supply to make sure the power is correct, stable, and has minimal ripple.
2. Check the loop wiring for degradation or improper grounding.
3. Remove the wiring compartment cover (considering hazardous location requirements) and check for water or terminal block corrosion.
4. Re-characterize the loop and adjust the deviation limit if necessary.

### Bluetooth® Functionality Limited

Field device is unable to send device data over Bluetooth due to an internal error. The field device will continue to function independently of this Bluetooth alert.

**Graphical LCD display** Bluetooth Functionality Limited

**LCD display** N/A

**Local operator interface (LOI)** N/A

#### Recommended actions

1. Remove the front housing cover (considering hazardous location requirements) and check that the display assembly is properly seated and connected to the electronic circuit board.
2. Replace the display (which contains the Bluetooth electronics).

### Bluetooth® Electronics Error

Field device internal diagnostics detected a Bluetooth electronics error. This error will likely result in a reduced or no Bluetooth communication capability; however the field device will continue to function independently of this Bluetooth alert.

**Graphical LCD display** Bluetooth Electronics Error

**LCD display** N/A

**Local Operator Interface (LOI)** N/A

#### Recommended actions

1. Remove the front housing cover (considering hazardous location requirements).
2. Replace the display (which contains the Bluetooth electronics).
3. Restart the device.

## 6.5 Disassembling the transmitter

### ⚠ WARNING

#### Explosion

Explosions could result in death or serious injury.

Do not remove the instrument cover in explosive atmospheres when the circuit is live.

### 6.5.1 Remove from service

#### ⚠ WARNING

Follow all plant safety rules and procedures.

#### Procedure

1. Power down device.
2. Isolate and vent the process from the transmitter before removing the transmitter from service.
3. Remove all electrical leads and disconnect conduit.
4. Remove the transmitter from the process connection.
  - The Rosemount 3051C Transmitter is attached to the process connection by four bolts and two cap screws. Remove the bolts and screws and separate the transmitter from the process connection. Leave the process connection in place and ready for reinstallation. See [Figure 3-4](#) for coplanar flange.
  - The Rosemount 3051T Transmitter is attached to the process by a single hex nut process connection. Loosen the hex nut to separate the transmitter from the process. Do not wrench on neck of transmitter. See warning in [Inline gauge transmitter orientation](#).
5. Clean isolating diaphragms with a soft rag and a mild cleaning solution, and rinse with clear water.

#### Note

Do not scratch, puncture, or depress the isolating diaphragms.

6. For the Rosemount 3051C, whenever you remove the process flange or flange adapters, visually inspect the PTFE O-rings. Replace the O-rings if they show any signs of damage, such as nicks or cuts.

#### Note

You may reuse undamaged O-rings.

### 6.5.2 Remove terminal block

Electrical connections are located on the terminal block in the compartment labeled **FIELD TERMINALS**.

#### Procedure

1. Remove the housing cover from the field terminal side.

2. Loosen the two small screws located on the assembly in the 9 o'clock and 5 o'clock positions relative to the top of the transmitter.
3. Pull the entire terminal block out to remove it.

### 6.5.3 Remove electronics board

The transmitter electronics board is located in the compartment opposite the terminal side.

#### Procedure

1. Remove the housing cover opposite the field terminal side.
2. If you are disassembling a transmitter with a local operator interface (LOI) or LCD display, loosen the two captive screws that are visible on the meter display.  
See [Figure 4-1](#) for screw locations. The two screws anchor the LOI/LCD display to the electronics board and the electronics board to the housing.

---

#### Note

The electronics board is electrostatically sensitive; observe handling precautions for static-sensitive components.

---

3. **Note**  
If an LOI/LCD display is installed, use caution as there is an electronic pin connector that interfaces between the LOI/LCD display and electronics board.
- 

### 6.5.4 Remove sensor module from the electronics housing

#### Procedure

1. Remove the electronics board.  
Refer to [Remove electronics board](#).

#### NOTICE

To prevent damage to the sensor module ribbon cable, disconnect it from the electronics board before you remove the sensor module from the electrical housing.

---

2. Carefully tuck the cable connector completely inside of the internal black cap.

#### NOTICE

Do not remove the housing until after you tuck the cable connector completely inside of the internal black cap. The black cap protects the ribbon cable from damage that can occur when you rotate the housing.

---

3. Using a 5/64-in. hex wrench, loosen the housing rotation set screw one full turn.
4. Unscrew the module from the housing, making sure the black cap on the sensor module and sensor cable do not catch on the housing.

## 6.6 Reassemble the transmitter

### Procedure

1. Inspect all cover and housing (non-process wetted) O-rings and replace if necessary. Lightly grease with silicone lubricant to ensure a good seal.
2. Carefully tuck the cable connector completely inside the internal black cap. To do so, turn the black cap and cable counterclockwise one rotation to tighten the cable.
3. Lower the electronics housing onto the module. Guide the internal black cap and cable on the sensor module through the housing and into the external black cap.
4. Turn the module clockwise into the housing.

---

### Note

Ensure the sensor ribbon cable and internal black cap remain completely free of the housing as you rotate it. Damage can occur to the cable if the internal black cap and ribbon cable become hung up and rotate with the housing.

---

5. Thread the housing completely onto the sensor module.  
The housing must be no more than one full turn from flush with the sensor module to comply with explosion proof requirements. See [Safety messages](#) for complete warning information.
6. Tighten the housing rotation set screw using a 5/64-in. wrench.

### 6.6.1 Attach electronics board

#### **⚠ WARNING**

#### Explosions

Explosions could result in death or serious injury.

In an explosionproof/flameproof installation, do not remove the transmitter covers when power is applied to the transmitter.

The transmitter covers must be engaged metal-to-metal to ensure a proper seal and to meet explosion-proof requirements.

---

#### Procedure

1. Remove the cable connector from its position inside of the internal black cap and attach it to the electronics board.
2. Using the two captive screws as handles, insert the electronics board into the housing.  
Ensure the power posts from the electronics housing properly engage the receptacles on the electronics board. Do not force. The electronics board should slide gently on the connections.
3. Tighten the captive mounting screws.
4. Replace the electronics housing cover.

## 6.6.2 Install terminal block

### Procedure

1. Gently slide the terminal block into place, making sure the two power posts from the electronics housing properly engage the receptacles on the terminal block.

#### **⚠ WARNING**

##### **Electrical shock**

Electrical shock can result in death or serious injury.

Avoid contact with the leads and terminals. High voltage that may be present on leads can cause electrical shock.

2. Tighten the captive screws.
3. Replace the electronics housing cover.

#### **⚠ WARNING**

##### **Explosions**

Explosions could result in death or serious injury.

The transmitter covers must be fully engaged to meet explosion-proof requirements.

## 6.6.3 Reassemble the Rosemount 3051C process flange

See [Safety messages](#) for complete warning information.

### Procedure

1. Inspect the sensor module PTFE O-rings.  
You may reuse undamaged O-rings. Replace O-rings that show any signs of damage, such as nicks, cuts, or general wear.

#### **Note**

If you are replacing the O-rings, be careful not to scratch the O-ring grooves or the surface of the isolating diaphragm when removing the damaged O-rings.

2. Install the process connection. Possible options include:
  - Coplanar process flange:
    - a. Hold the process flange in place by installing the two alignment screws to finger tightness (screws are not pressure retaining). Do not over-tighten, as this will affect module-to-flange alignment.
    - b. Install the four 1.75-in. flange bolts by finger tightening them to the flange.
  - Coplanar process flange with flange adapters:
    - a. Hold the process flange in place by installing the two alignment screws to finger tightness (screws are not pressure retaining). Do not over-tighten, as this will affect module-to-flange alignment.
    - b. Hold the flange adapters and adapter O-rings in place while installing (in the desired of the four possible process connection spacing configurations) using four 2.88-in. bolts to mount securely to the coplanar



flange. For gauge pressure configurations, use two 2.88-inch bolts and two 1.75-in. bolts.

- Manifold: Contact the manifold manufacturer for the appropriate bolts and procedures.
3. Tighten the bolts to the initial torque value using a crossed pattern. See [Table 6-1](#) for appropriate torque values.
  4. Using the same cross pattern, tighten bolts to final torque values seen in [Table 6-1](#).

**Note**

If you replaced the PTFE sensor module O-rings, re-torque the flange bolts after installation to compensate for cold flow of the O-ring material.

**Note**

For Range 1 transmitters, after replacing O-rings and re-installing the process flange, expose the transmitter to a temperature of 185 °F (85 °C) for two hours. Then re-tighten the flange bolts in a cross pattern and again expose the transmitter to a temperature of 185 °F (85 °C) for two hours before calibration.

**Table 6-1: Bolt installation torque values**

Bolt material	Initial torque value	Final torque value
CS-ASTM-A445 Standard	300 in.-lb (34 N-m)	650 in.-lb (73 N-m)
316 SST—Option L4	150 in.-lb (17 N-m)	300 in.-lb (34 N-m)
ASTM-A-19 B7M—Option L5	300 in.-lb (34 N-m)	650 in.-lb (73 N-m)
ASTM-A-193 Class 2, Grade B8M—Option L8	150 in.-lb (17 N-m)	300 in.-lb (34 N-m)

## 6.6.4 Install drain/vent valve

**Procedure**

1. Apply sealing tape to the threads on the seat. Starting at the base of the valve with the threaded end pointing toward the installer, apply five clockwise turns of sealing tape.

**NOTICE**

Take care to place the opening on the valve so that process fluid will drain toward the ground and away from human contact when the valve is opened.

2. Tighten the drain/vent valve to 250 in.-lb. (28.25 N-m).

## 6.7 Service support

Within the United States, call the Emerson Instrument and Valve Response Center using the 1-800-654-RSMT (7768) toll-free number. This center, available 24 hours a day, will assist you with any needed information or materials.

The center will ask for product model and serial numbers and will provide a Return Material Authorization (RMA) number. The center will also ask for the process material to which the product was last exposed.

For inquiries outside of the United States, contact the nearest Emerson representative for RMA instructions.

To expedite the return process outside of the United States, contact the nearest Emerson representative.

### **⚠ WARNING**

#### **Hazardous substances**

Individuals who handle products exposed to a hazardous substance may be injured.

You can avoid injury by learning about and understanding the hazard.

Include a copy of the required Material Safety Data Sheet (MSDS) for each substance with the returned goods.

Emerson Instrument and Valve Response Center representatives will explain the additional information and procedures necessary to return goods exposed to hazardous substances.

---

# 7 Safety Instrumented Systems (SIS) requirements

A two-wire, 4-20 mA signal representing pressure provides the safety-critical output of the Rosemount 3051 Pressure Transmitter. The Rosemount 3051 safety-certified pressure transmitter is certified to:

- Low and high demand: Type B element
- Route 2H, Low Demand application: SIL 2 for random integrity at HFT=0, SIL 3 for random integrity at HFT=1
- Route 2H, High Demand application: SIL 2 and SIL3 for random integrity at HFT=1
- Route 1H where the SFF  $\geq$  90%: SIL 2 for random integrity at HFT=0, SIL 3 for random integrity at HFT=1
- SIL 3 for systematic integrity

## 7.1 Identify Rosemount 3051 safety certification

You must identify all Rosemount 3051 transmitters as safety-certified before installing them into Safety Instrumented Systems (SIS). To identify a safety-certified Rosemount 3051:

### Procedure

1. Check NAMUR Software Revision located on the metal device tag: SW\_.\_.\_.  
NAMUR Software Revision Number: SW<sup>(6)</sup> 1.0.x-1.4.x and 2.0.x. See [Table 2-1](#).
2. Verify that option code **QT** is included and **TR** is not included in the transmitter model code.  
Devices used in safety applications with ambient temperatures below -40 °F (-40 °C) require option codes **QT** and **BR5** or **BR6**.

## 7.2 Installation in Safety Instrumented Systems (SIS) applications

There are no additional instructions for installing the transmitter in SIS applications.

### **⚠ WARNING**

Only allow qualified personnel to install the Rosemount 3051 in SIS applications.

Always ensure a proper seal by installing the electronics housing cover(s) so that metal contacts metal.

See the *Specifications* section of the [Rosemount 3051 Product Data Sheet](#) for environmental and operational limits.

Design the loop so that terminal voltage does not drop below 10.5 Vdc when the transmitter output is set to 23 mA.

<sup>(6)</sup> NAMUR Software Revision: Located on the metal device tag.

Set the **Security** switch to Lock to prevent accidental or deliberate change of configuration data during normal operation.

## 7.3 Configuring in Safety Instrumented Systems (SIS) applications

Use any HART® capable configuration tool to communicate with and verify configuration of the Rosemount 3051.

### NOTICE

Transmitter output is not safety-rated during the following: configuration changes, multidrop, and loop test. Use alternative means to ensure process safety during transmitter configuration and maintenance activities.

### 7.3.1 Damping

User-selected damping affects the transmitter's ability to respond to changes in the applied process. The damping value + response time must not exceed the loop requirements.

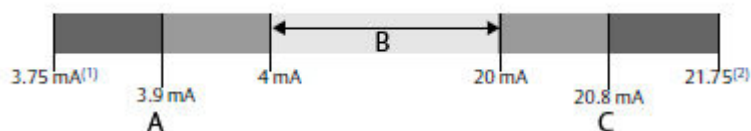
Reference [Damping](#) to change damping value.

### 7.3.2 Alarm and saturation levels

Configure DCS or safety logic solver to match transmitter configuration.

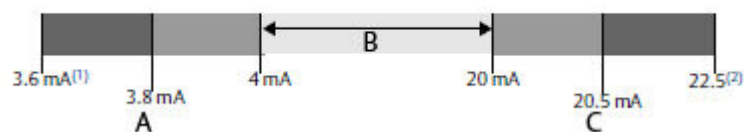
The figures below identify the three alarm levels available and their operation values.

**Figure 7-1: Rosemount alarm level**



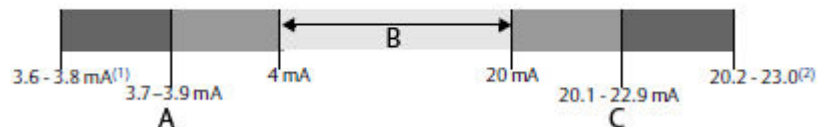
- A. Low saturation
- B. Normal operation
- C. High saturation

**Figure 7-2: NAMUR alarm level**



- A. Low saturation
- B. Normal operation
- C. High saturation

Figure 7-3: Custom alarm level



- A. Low saturation
- B. Normal operation
- C. High saturation

1. Transmitter failure, hardware, or software alarm in LO position.
2. Transmitter failure, hardware, or software alarm in HI position.

## 7.4 Safety Instrumented Systems (SIS) operation and maintenance

### 7.4.1 Proof-tests

Emerson recommends the following proof-tests.

If you find an error in safety or functionality, you can document proof-test results and corrective actions taken at [Emerson.com/ReportFailure](https://emerson.com/reportfailure).

#### **⚠ WARNING**

Only allow qualified personnel to perform proof-tests.

Verify the **Security** switch is in the Unlock position during the proof-test and reposition it in the Lock position after the proof-test.

### 7.4.2 Perform a guided proof-test

If you select the guided proof-test option, the Rosemount 3051 will support a feature that can perform a guided partial or comprehensive proof-test.

This feature walks you through the necessary steps to perform a proof-test. The alarm levels and required steps will be provided without the need to look them up.

To access the guided proof-test option:

#### **Procedure**

Go to **Device Settings** → **Calibration** → **Proof Test** → **Perform Proof Tests**.

The guided proof-test option comes with a proof-test log. This log stores the ten most recent proof-tests directly in the transmitter. The log includes time stamp, communication source, Pass/Fail result, and any user-defined notes.

### 7.4.3 Partial proof-test

The simple suggested proof-test consists of a power cycle plus reasonability checks of the transmitter output.

See the *Failure Modes, Effects, and Diagnostic Analysis Report* at [Emerson.com/Rosemount3051CP](https://www.emerson.com/documents/products-services/rosemount3051cp).

#### Prerequisites

Required tools:

- Communication device
- mA meter

#### Procedure

1. Bypass the safety function and take appropriate action to avoid a false trip.
2. Use HART® communication to retrieve any diagnostics and take appropriate action.
3. Select a HART command to the transmitter to the high alarm current output and verify that the analog current reaches that value.<sup>(7)</sup>  
See [Verifying alarm level](#).
4. Send a HART command to the transmitter to go to the low alarm current output and verify that the analog current reaches that value.<sup>(7)</sup>
5. Remove the bypass and otherwise restore the normal operation.
6. Place the **Security** switch in the Lock position.

### 7.4.4 Comprehensive proof-test

The comprehensive proof-test consists of performing the same steps as the simple suggested proof-test but with a two-point calibration of the pressure sensor instead of the reasonability check.

See the *Failure Modes, Effects and Diagnostic Analysis Report* at [Emerson.com/Rosemount3051CP](https://www.emerson.com/documents/products-services/rosemount3051cp) for percent of possible DU failures in the device.

#### Prerequisites

Required tools:

- Communication device
- Pressure calibration equipment

#### Procedure

1. Bypass the safety function and take appropriate action to avoid a false trip.
2. Use HART communication to retrieve any diagnostics and take appropriate action.
3. Send a HART command to the transmitter to go to the high alarm current output and verify that the analog current reaches that value.<sup>(7)</sup>  
See [Verifying alarm level](#).
4. Send a HART command to the transmitter to go to the low alarm current output and verify that the analog current reaches that value.<sup>(8)</sup>

---

<sup>(7)</sup> This tests for possible quiescent current related failures.

<sup>(8)</sup> This tests for compliance voltage problems, such as a low loop power supply voltage or increased wiring distance. This also tests for other possible failures.

5. Perform a two-point calibration of the sensor over the full working range and verify the current output at each point.  
See [Trimming the pressure signal](#).
6. Remove the bypass and otherwise restore the normal operation.
7. Place the **Security** switch in the Lock position.

#### NOTICE

- You determine the proof-test requirements for impulse piping.
- Automatic diagnostics are defined for the corrected % DU. The device performs these tests internally during runtime without requiring you to enable or program the transmitter.

## 7.4.5 Calculation of average probability of failure on demand (PFD<sub>AVG</sub>)

See the Failure Mode, Effects and Diagnostic Analysis Report at [Emerson.com/Rosemount3051CP](#) for the PFD<sub>AVG</sub> calculation.

## 7.5 Inspection

### 7.5.1 Product repair

You can repair the Rosemount 3051 by replacing major components.

Report all failures detected by the transmitter diagnostics or by the proof-test. Submit feedback electronically.

#### ⚠ WARNING

Only allow qualified personnel to repair the product and replace parts.

### 7.5.2 Rosemount 3051 Safety Instrumented Systems (SIS) reference

Operate the Rosemount 3051 in accordance with the functional and performance specifications provided in the *Specifications* section of the [Rosemount 3051 Product Data Sheet](#).

### 7.5.3 Failure rate data

See the *Failure Modes, Effects and Diagnostic Analysis Report* at [Emerson.com/Rosemount3051CP](#) for failure rates and common cause Beta factor estimates.

### 7.5.4 Failure values

**Safety deviation** ±2.0 percent

**Transmitter response time** See the *Specifications* section of the [Rosemount 3051 Product Data Sheet](#).

**Self-diagnostics test interval** At least once every 60 minutes

## 7.5.5 Product life

50 years - based on worst case component wear-out mechanisms; not based on wear-out of process wetted materials.



# A Reference data

## A.1 Ordering information, specifications, and drawings

To view current Rosemount 3051 ordering information, specifications, and drawings, follow these steps:

### Procedure

1. Go to [Emerson.com/Rosemount3051CP](https://emerson.com/Rosemount3051CP).
2. Scroll as needed to the green menu bar and click **Documents & Drawings**.
3. For installation drawings, click **Drawings & Schematics** and select the appropriate document.
4. For ordering information, specifications, and dimensional drawings, click **Data Sheets & Bulletins** and select the appropriate Product Data Sheet.
5. For the Declaration of Conformity, click **Certificates & Approvals** and select the most current document.

## A.2 Product certifications

To view current Rosemount 3051 product certifications, see the [Rosemount 3051 Quick Start Guide](#).



# B Device Driver (DD) menu trees

Figure B-1: First level menu trees

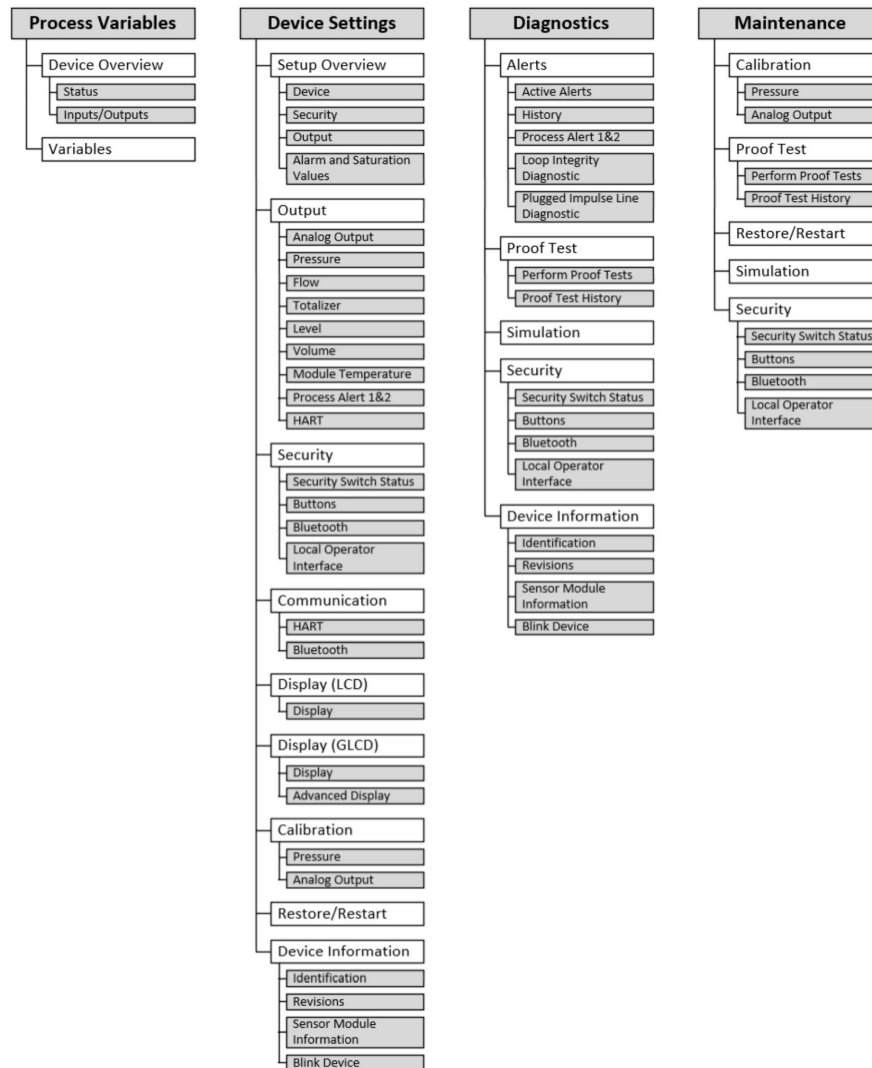


Figure B-2: Process Variables menu

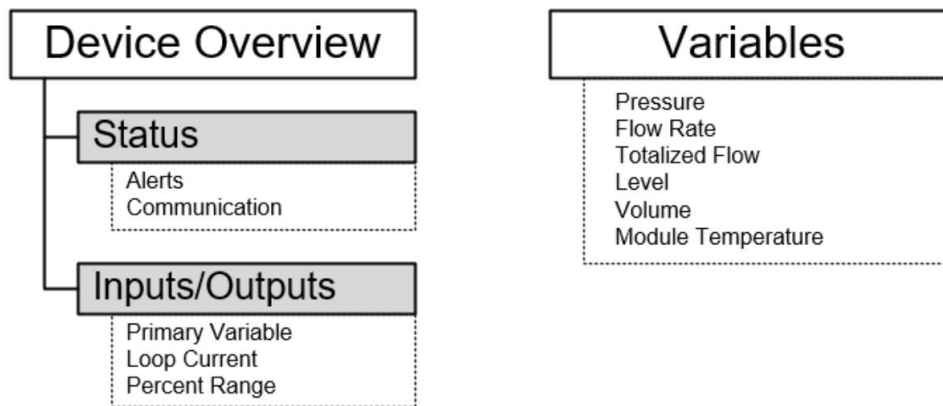


Figure B-3: Device Settings 1

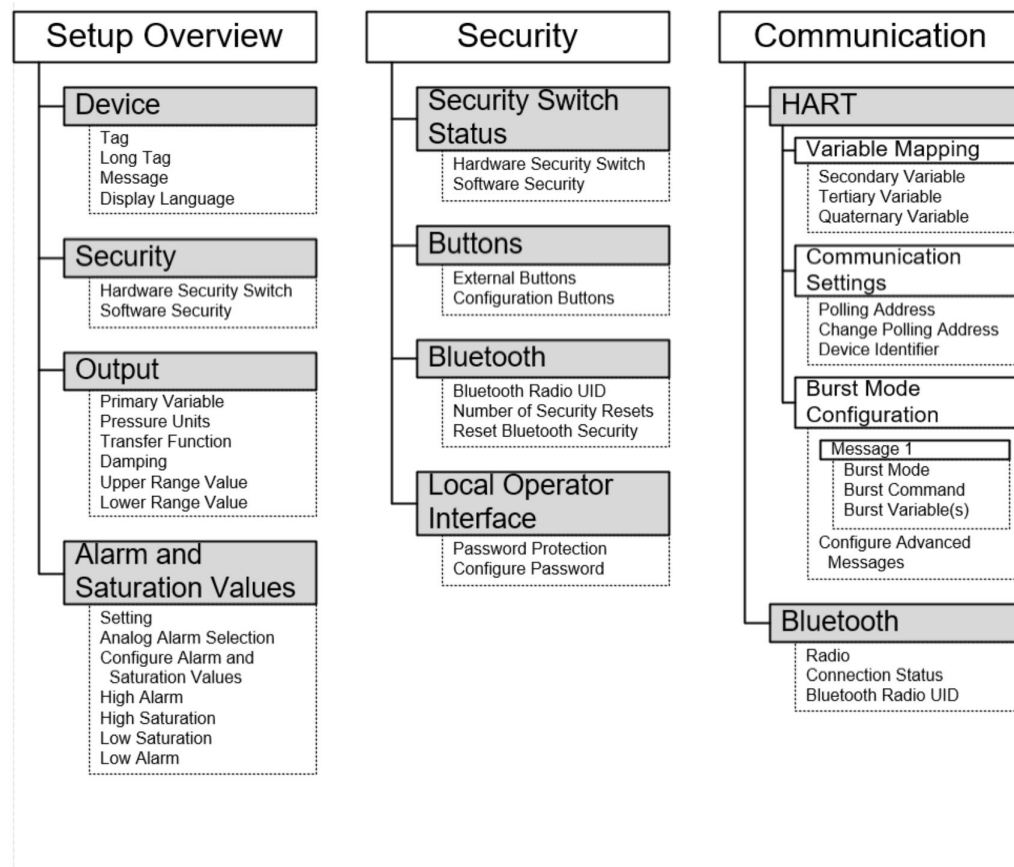


Figure B-4: Device Settings 2

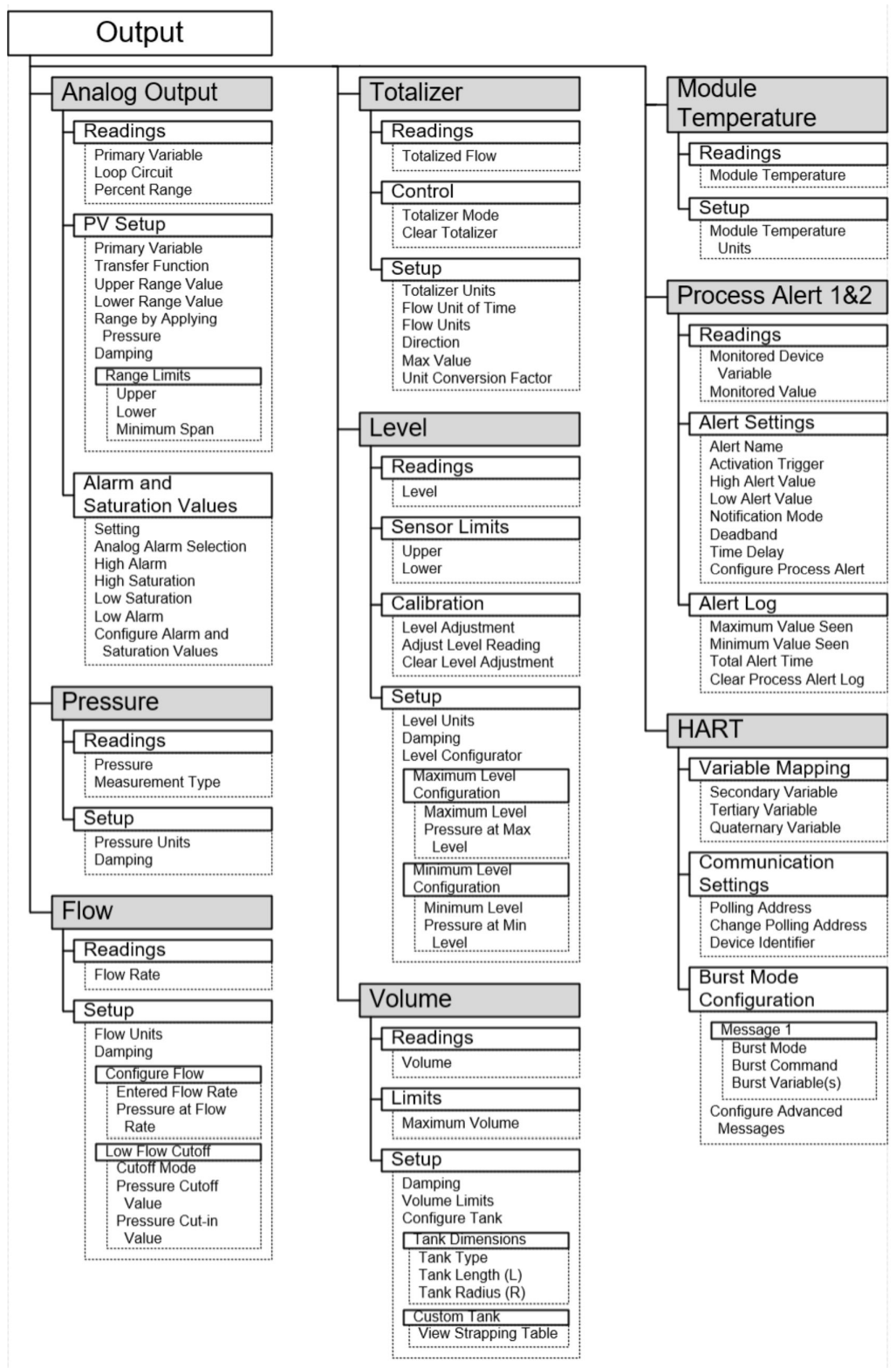


Figure B-5: Device Settings 3

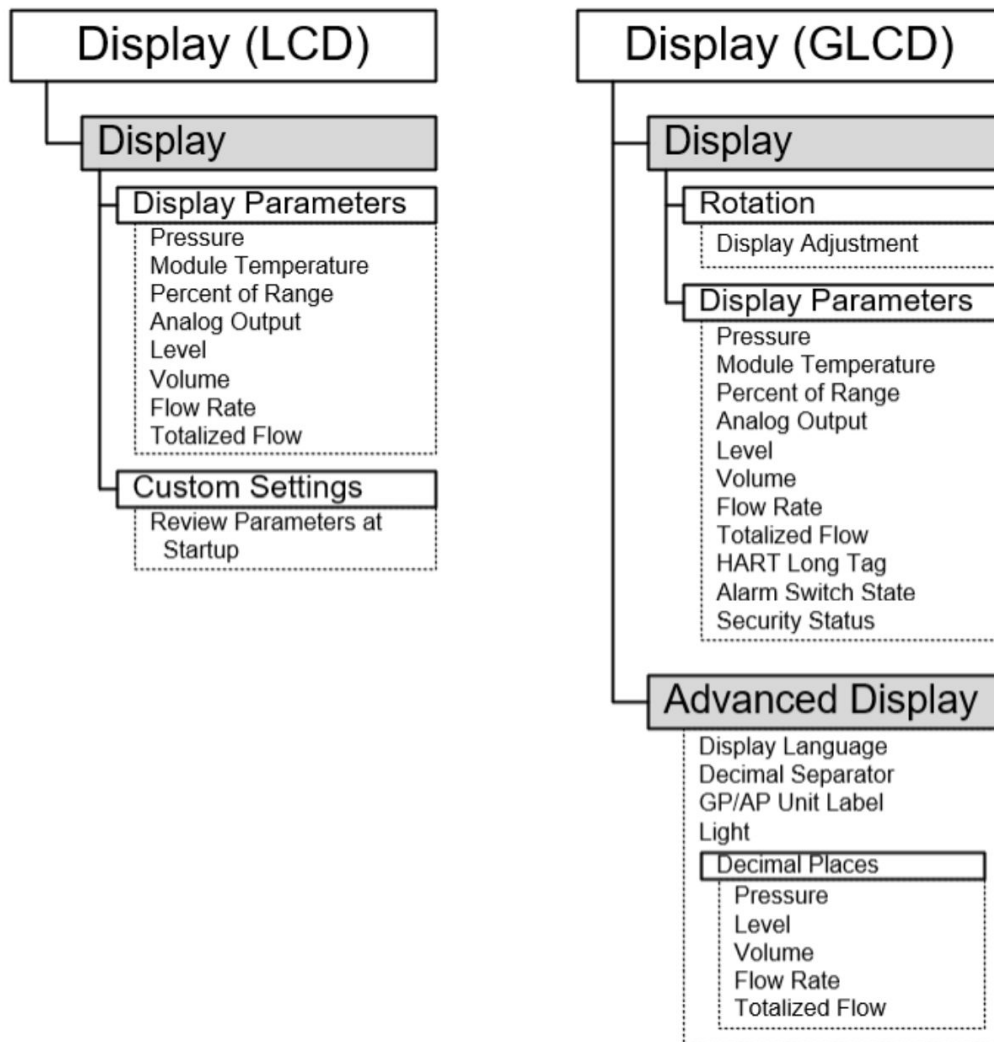


Figure B-6: Device Settings 4

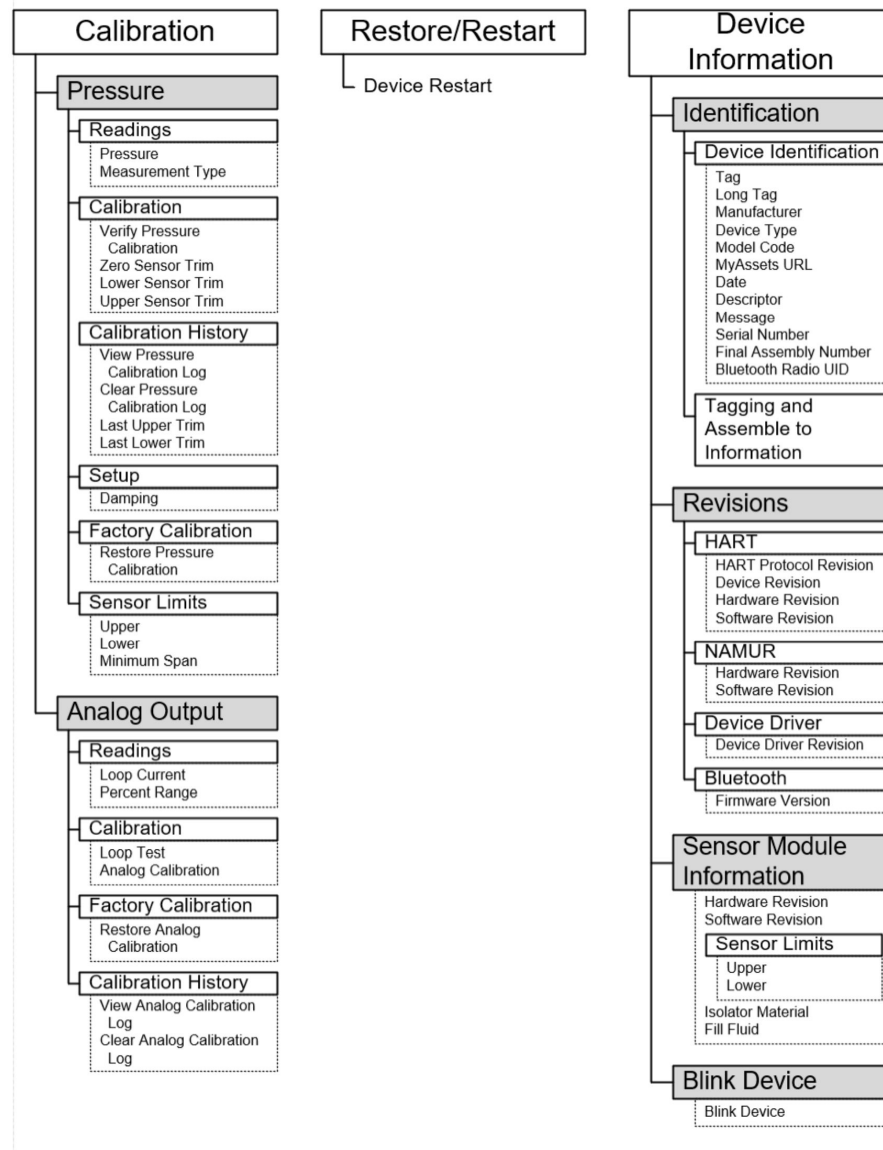


Figure B-7: Diagnostics 1

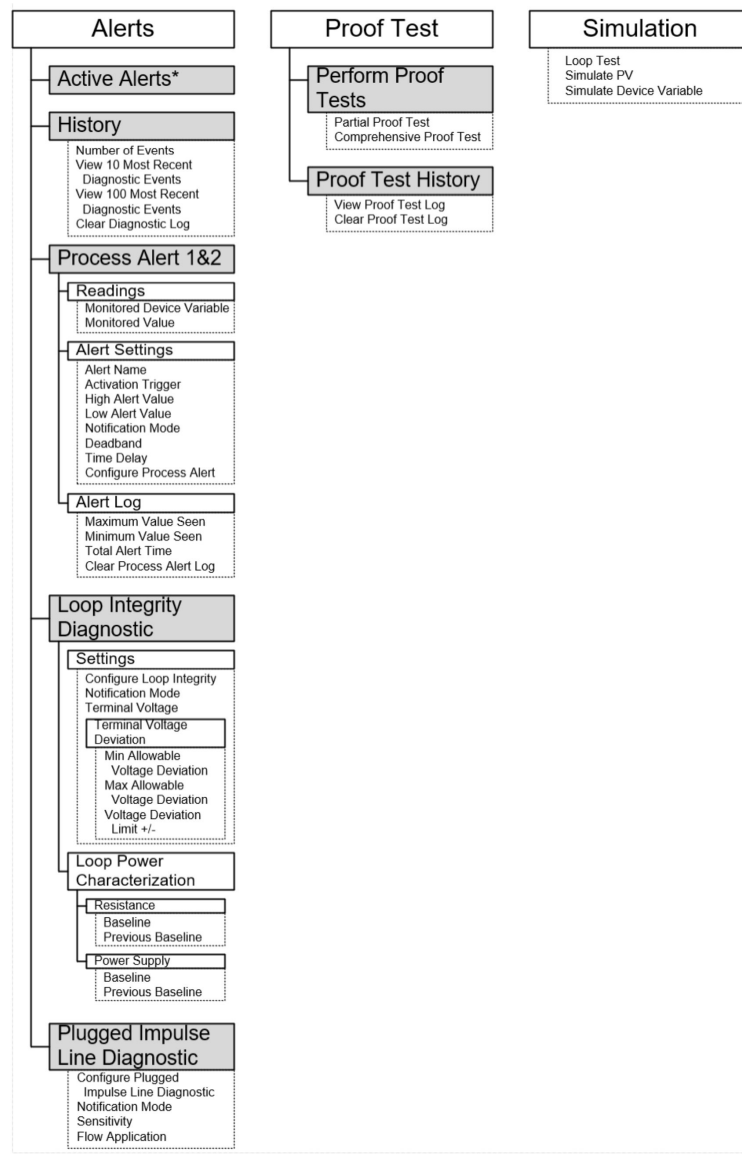




Figure B-8: Diagnostics 2

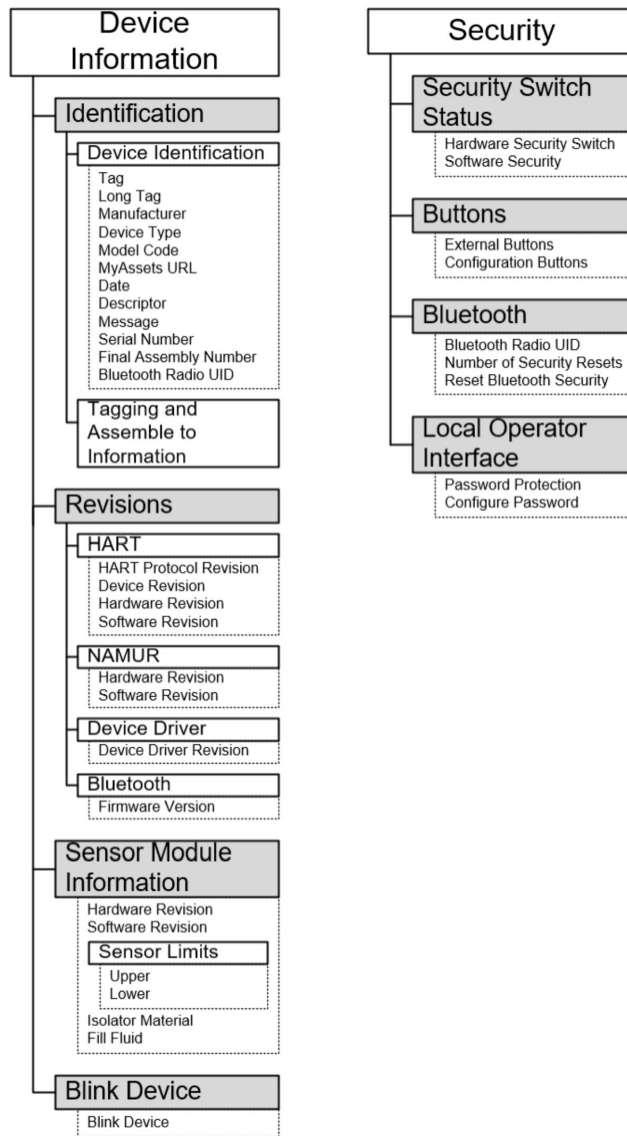


Figure B-9: Maintenance 1

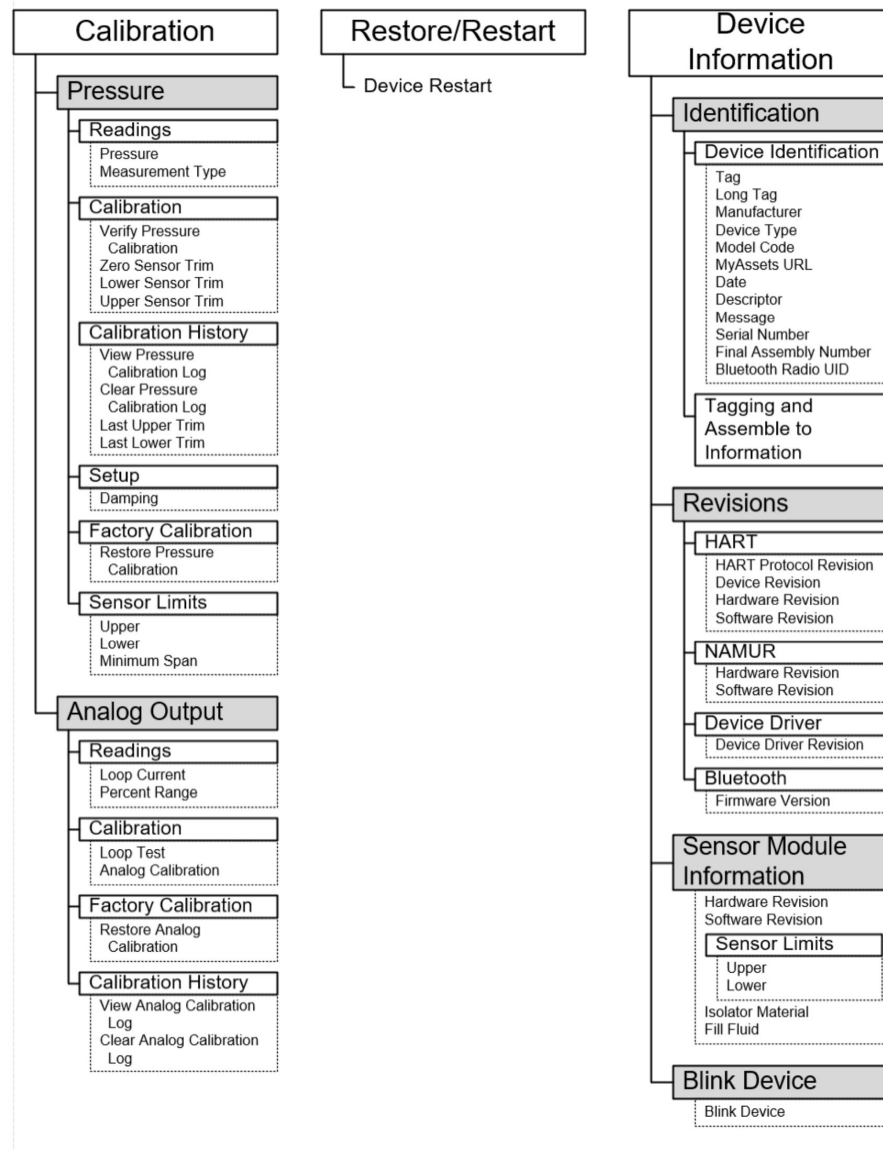
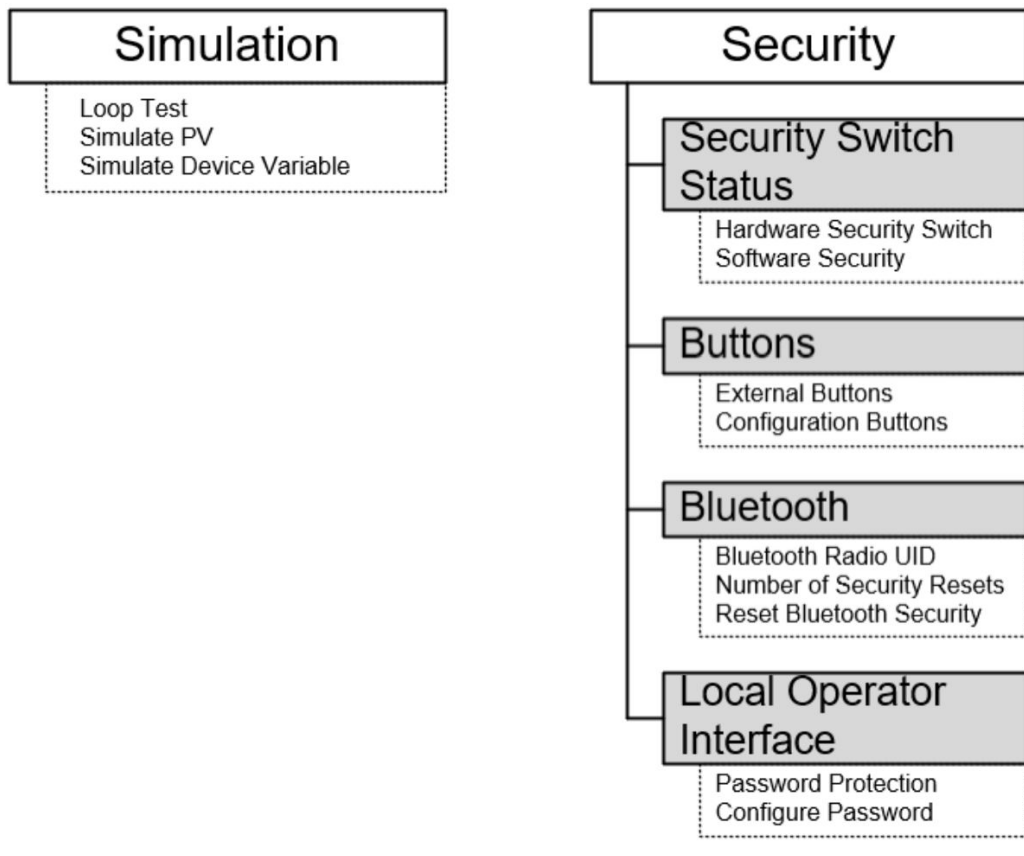


Figure B-10: Maintenance 2





## C Quick Service buttons

Menu title	Button
View Config	PV (Primary Variable)
	PV Damping
	PV URV
	PV LRV
	AO Alarm (Analog Output)
	HI Saturation
	LO Saturation
Zero	Trim to PV Zero
	Set current reading as 4 mA
Rerange	Set 4 mA
	Set 20 mA
Loop Test	Set 4 MA
	Set 8 MA
	Set 12 MA
	Set 16 MA
	Set 20 MA
Flip screen	Flip 180 Degrees



## D Local Operator Interface (LOI)

### D.1 Enter numbers in the Local Operator Interface (LOI)

You can enter floating-point numbers with the LOI using all eight number locations on the top line.

The steps below give an example of how to change a value of `-0000022` to `000011.2`.

When the number entry begins, the leftmost position is the selected position. In this example, the negative symbol "-" is flashing on the screen: `_0000022`

#### Procedure

1. Press the **Scroll** button until the 0 is blinking on the screen in the selected position.  
`00000022`
2. Press the **Enter** button to select 0 as an entry.  
The second digit from the left is blinking: `00000022`
3. Press the **Enter** button to select 0 for the second digit.  
The third digit from the left is blinking: `00000022`
4. Press the **Enter** button to select 0 for the third digit.  
The fourth digit from the left is blinking: `00000022`
5. Press the **Enter** button to select 0 for the fourth digit.  
The fifth digit from the left is blinking: `00000022`
6. Press the **Scroll** button to navigate through the numbers until 1 is on the screen.  
`00001022`
7. Press the **Enter** button to select 1 for the fifth digit.  
The sixth digit from the left is blinking: `00001022`
8. Press the **Scroll** button to navigate through the numbers until 1 is on the screen.  
`00001122`
9. Press the **Enter** button to select 1 for the sixth digit.  
The seventh digit from the left is blinking: `00001122`
10. Press the **Scroll** button to navigate through the numbers until the decimal "." is on the screen.  
`000011.2`
11. Press the **Enter** button to select the decimal "." for the seventh digit.  
After you press **Enter**, all digits to the right of the decimal become 0. The eighth digit from the left is blinking: `000011.0`
12. Press the **Scroll** button to navigate through the numbers until 2 is on the screen.  
`000011.2`
13. Press the **Enter** button to select 2 for the eighth digit.  
`000011.2`

The number entry is complete. A **SAVE** screen appears.

Usage notes:

- To move backwards in the number, scroll to the Left arrow symbol and press **Enter**.

- The negative symbol is only allowed in the leftmost position.
- To enter numbers in scientific notation, place an  $E$  in the seventh position.

## D.2 Enter text in the Local Operator Interface (LOI)

Depending on the edited item, you can enter text in up to eight locations on the top line.

Text entry follows the same rules as the number entry rules in [Enter numbers in the Local Operator Interface \(LOI\)](#), except the following characters are available in all locations: A-Z, 0-9, -, /, space.

---

### Note

If the current text contains a character the LOI cannot display, it will be shown as an asterisk "\*".

---





For more information: [Emerson.com/global](https://emerson.com/global)

©2023 Emerson. All rights reserved.

Emerson Terms and Conditions of Sale are available upon request. The Emerson logo is a trademark and service mark of Emerson Electric Co. Rosemount is a mark of one of the Emerson family of companies. All other marks are the property of their respective owners.

The "Bluetooth" word mark and logos are registered trademarks owned by Bluetooth, SIG, Inc. and any use of such marks by Emerson is under license.

**ROSEMOUNT™**

